

Thank you for your purchase!

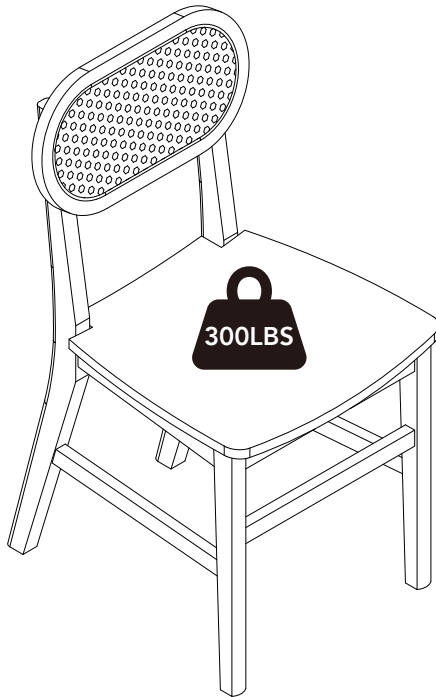

Set of 2 Wooden Chairs with Rattan Backrests

ASSEMBLY INSTRUCTIONS

Before You Begin:

Please identify all component parts and hardware pieces required before you begin. Carefully remove all of the components from the packaging and set aside for assembly. Assemble on a soft surface to prevent scratching during assembly.

Caution:

Tighten all components securely before use. Failure to do so may result in personal injury. DO NOT use any sharp objects to open plastic wrapped components as damage to product or components may result.

Warning:





CHOKING HAZARD - Small Parts. Adult Assembly Required.

DO NOT ALLOW CHILDREN TO CLIMB ON FURNITURE

Serious or fatal injuries can occur from furniture tipping over. You must install Tipping Restraint Hardware (where included) to help prevent the unit from tipping and causing accidental injury, instability, death or damage. The tipping restraint is intended only as a safety measure, it is not a substitute for proper adult supervision.

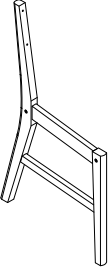
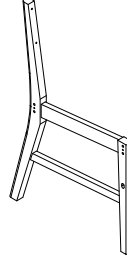
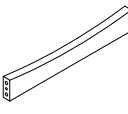
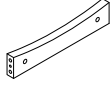
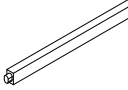
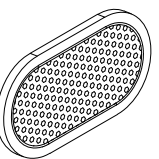
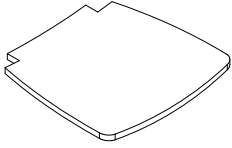
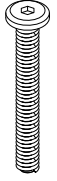
To help prevent furniture from tipping over it must be permanently attached to the wall. Anti-Tip Safety Wall Straps suitable for the unit weight and wall materials (if not included) should be purchased and installed.

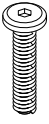
PARTS

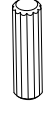
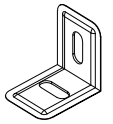
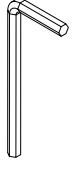
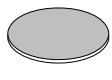
<p>(1)X1</p>  <p>Right Wood Frame</p>	<p>(2)X1</p>  <p>Left Wood Frame</p>	<p>(3)X1</p>  <p>Upper Front Rail</p>	<p>(4)X1</p>  <p>Back Rail</p>	<p>(5)X1</p>  <p>Lower Front Rail</p>	<p>(6)X1</p>  <p>Backrest</p>	<p>(7)X1</p>  <p>Seat</p>		
<p>(8)X4</p>  <p>M6*60 Bolt</p>	<p>(9)X4</p>  <p>M10*12 Nut</p>	<p>(10)X4</p>  <p>M6*35 Bolt</p>	<p>(11)X2</p>  <p>Ø4*40 Screw</p>	<p>(12)X8</p>  <p>Ø4*12 Screw</p>	<p>(13)X8</p>  <p>Ø8*30 Wooden Dowel</p>	<p>(14)X4</p>  <p>L-Bracket</p>	<p>(15)X1</p>  <p>M4 Allen Wrench</p>	<p>(16)X4</p>  <p>Felt Pad</p>

STEP 1

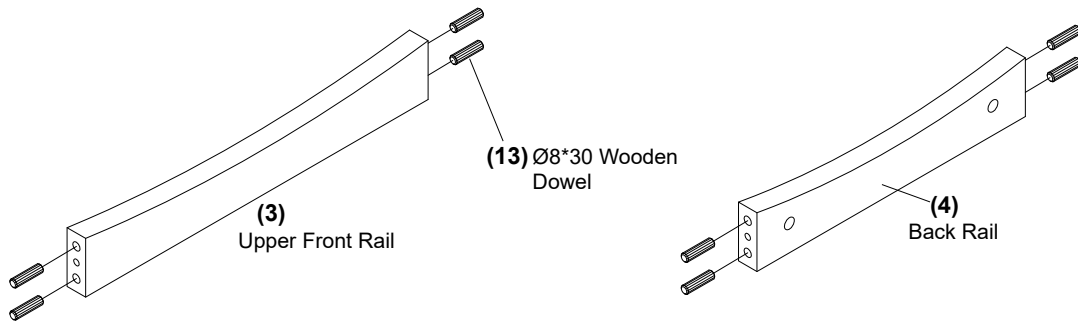

STEP 2

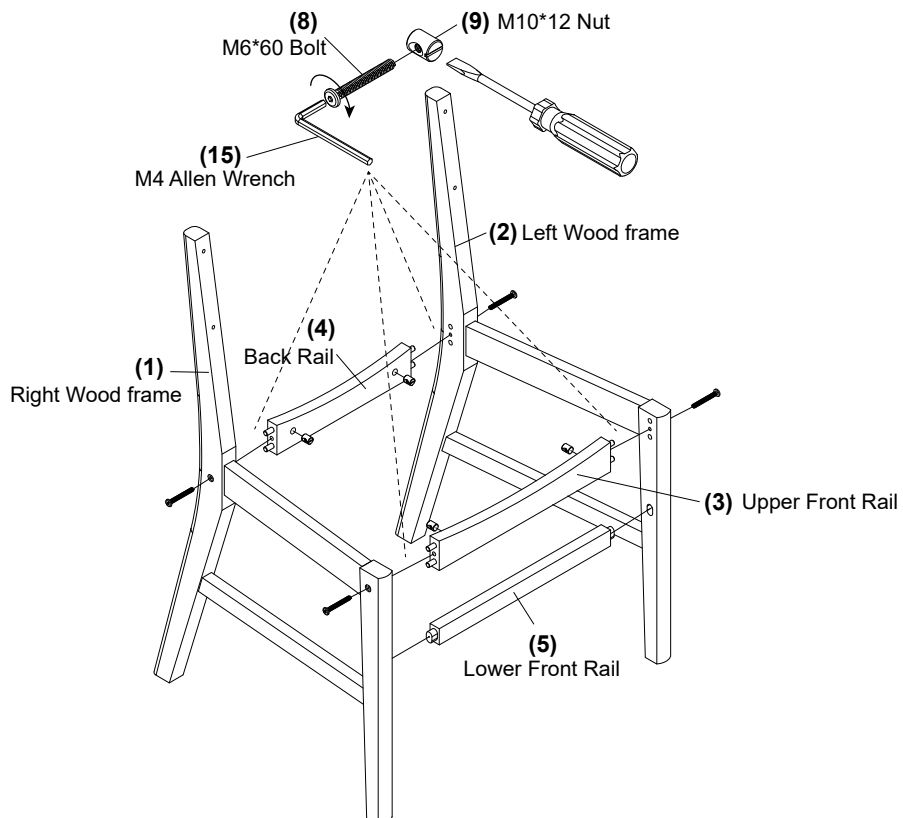

STEP 3

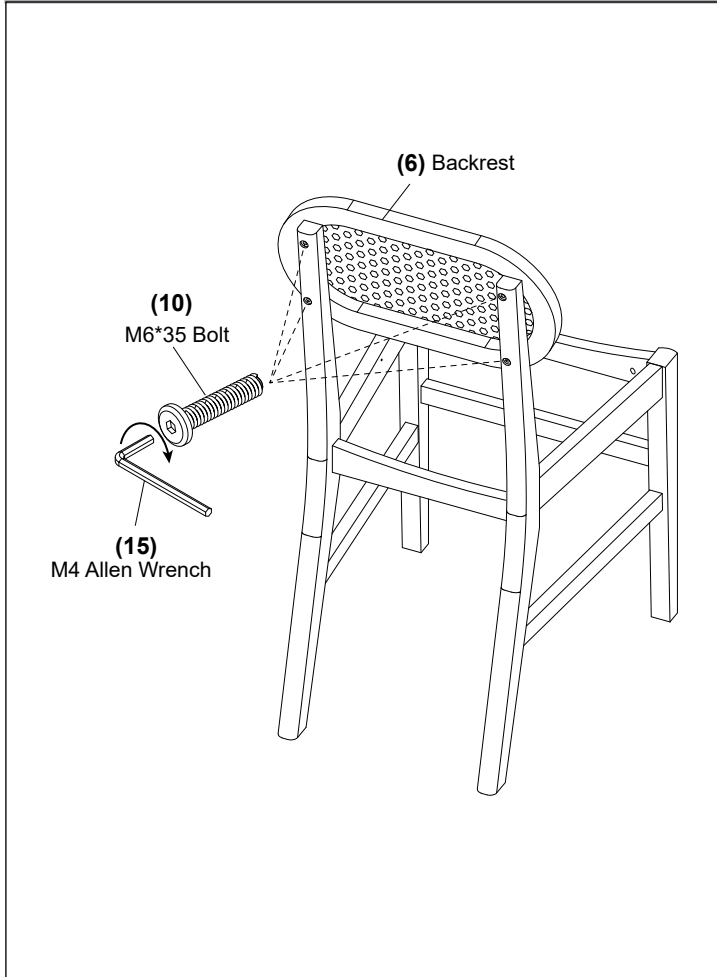

STEP 4

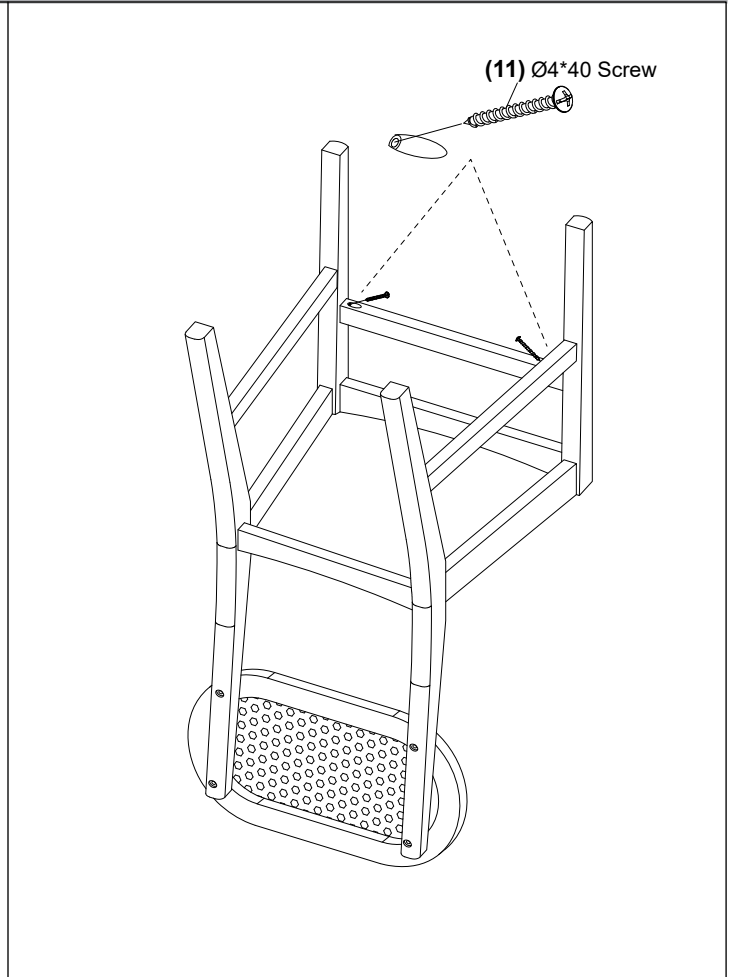

STEP 5

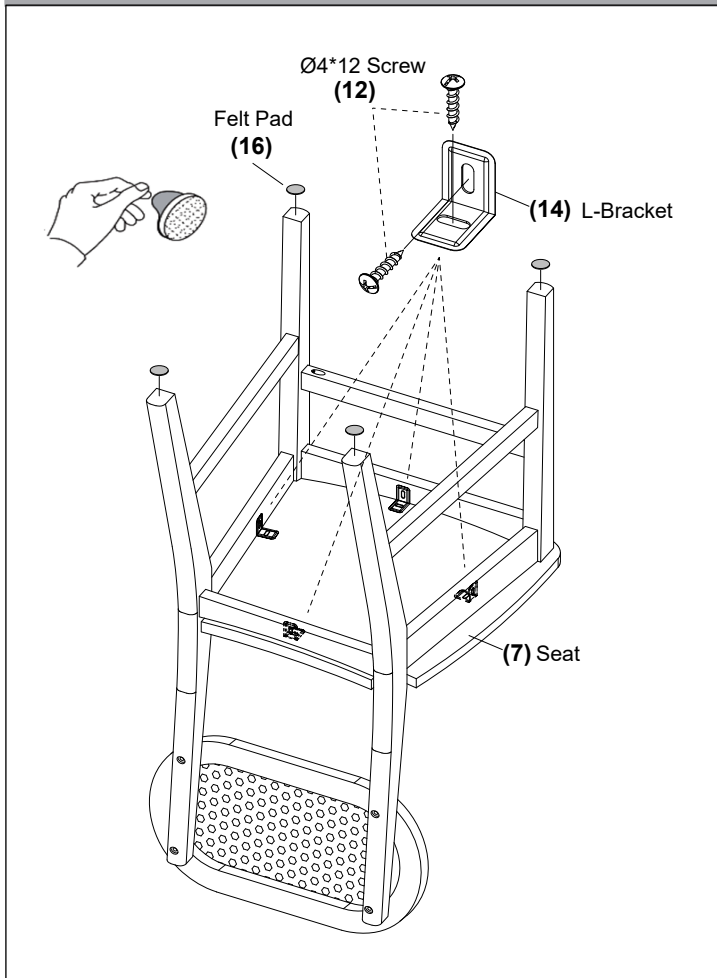

STEP 6

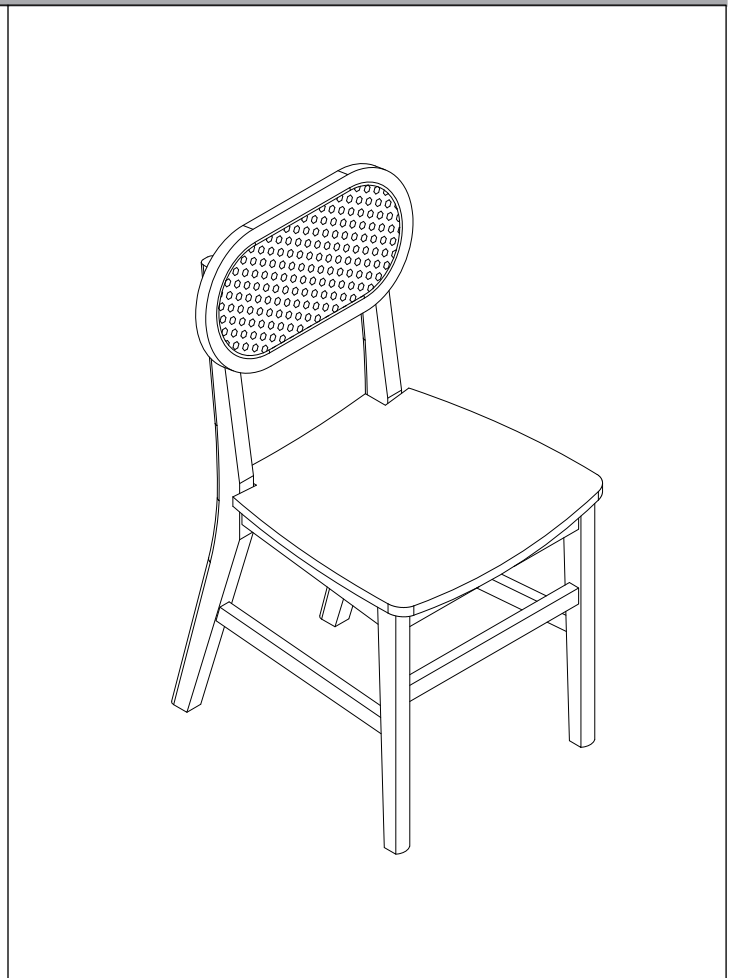

Quality and Safety Guidelines:

- Please follow the static and dynamic weight capacity limits provided on this item. If you are unsure of the weight capacities for this product,
- Please use this item on a stable, level surface only. All chair legs should contact the flooring surface when in use. Do not use this item if any instability is detected.
- This chair is not intended for reclined positions. To prevent accidental tipping, do not push backward or forward while seated.
- Do not slide the chair forward, backwards or sideways while seated in this chair.
- For maintenance instructions and replacement parts, please email us at
- This item is intended for sitting only, do not climb or stand on this item.
- This chair was designed to be used indoors.
- For product longevity, product safety and product integrity, protect from wet weather and store indoors in a dry location. For additional storage instructions,.
-