

ASSEMBLY INSTRUCTIONS

ARROWBACK CHAIR

ASSEMBLY
REQUIREMENTS:

1-Person
Assembly

30 Minutes
Assembly Time
Per Chair
(Approximate)

Tools Required:
(Not Provided)

Phillips
Screwdriver



Thank you for purchasing our product!

Please refer and use this assembly instruction to assemble the product. Contact our customer service department in case there are any missing or damage parts or hardware. Replacement parts are normally shipped within 2 or 3 days.

PRODUCTS PURCHASED THROUGH OUR AUTHORIZED VENDORS ONLY ARE ELIGIBLE FOR REPLACEMENT PARTS

We appreciate your business!"

THIS PRODUCT IS FOR INDOOR AND HOUSEHOLD USE ONLY- NOT FOR COMMERCIAL USE.



ASSEMBLY PREPARATION

1. Remove all packaging materials, staples and packing straps from the carton.
2. Refer to Parts List and Hardware List, and ensure parts and hardware are correct before assembly. contact customer service for missing parts.
3. Place all wooden parts on a clean, flat and soft surface (e.g. carpet or rug) to prevent scratch and damage to parts.

SAFETY PRECAUTION:

1. KEEP ALL HARDWARE PARTS OUT OF REACH OF CHILDREN.
2. DISPOSE PLASTIC PACKAGING MATERIAL IMMEDIATELY TO AVOID ANY RISK OF SUFFOCATION TO CHILDREN AND ANIMALS.

TIPS FOR ASSEMBLY:

1. Allow ample room for assembly and assemble the product near where the product will be placed.
2. Assemble the product on a surface that does not scratch or damage the exterior gloss and finish of the furniture.
3. Identify all of the parts, hardware and quantities required for each step.
4. During assembly, do not over-tighten any fittings as this may cause damage.
5. DO NOT USE POWER TOOLS TO ASSEMBLE THIS PRODUCT.
6. Always place the product on a flat, level surface.
7. Do not sit or stand on the partially assembled product; only use the product for which it is intended.







CARE AND MAINTENANCE

1. Wipe clean with a soft, dry cloth; avoid the use of harsh chemicals or household cleaners as they may damage the exterior finish of the furniture.
2. Hardware may loosen over time. Periodically, check that all connections are tight; re-tighten as necessary.
3. Solid wood is impacted by heat and humidity fluctuations and may result in small joint separations or hairline cracks; place the furniture away from direct sunlight and air conditioning vents, heating vents or units to protect the furniture.

PARTS LIST (FOR 1 COMPLETE CHAIR)

NO	DESCRIPTION	QTY
A	Chair Back	1
B	Leg Frame	2
C	Stretchers (Short)	1
D	Stretchers (Long)	1

HARDWARE LIST (FOR 1 COMPLETE CHAIR)

NO	DESCRIPTION	QTY
E	JCBC Bolt M6 X 50MM 	2
F	Barrel Nut M6 X 13MM 	2
G	JCBC Screw M7 X 35MM 	6
H	Allen Key M4 	1
I	Wood Button 	2
J	Glue 	1

Instructions For Installing Barrel Nut

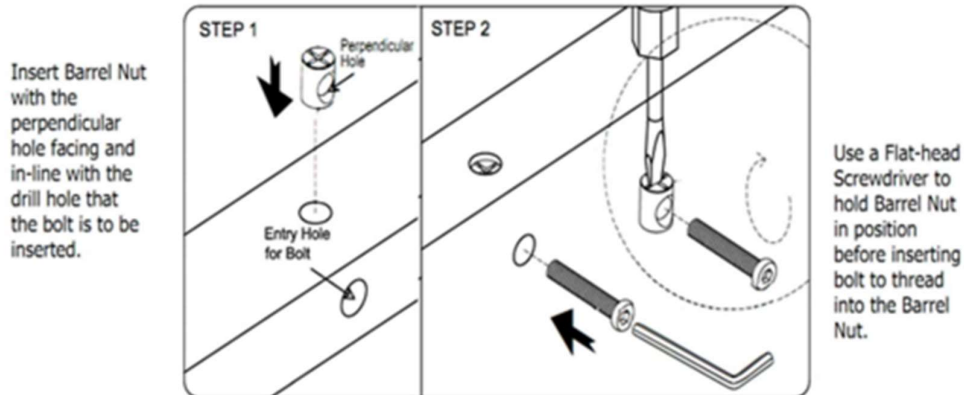

Step 1

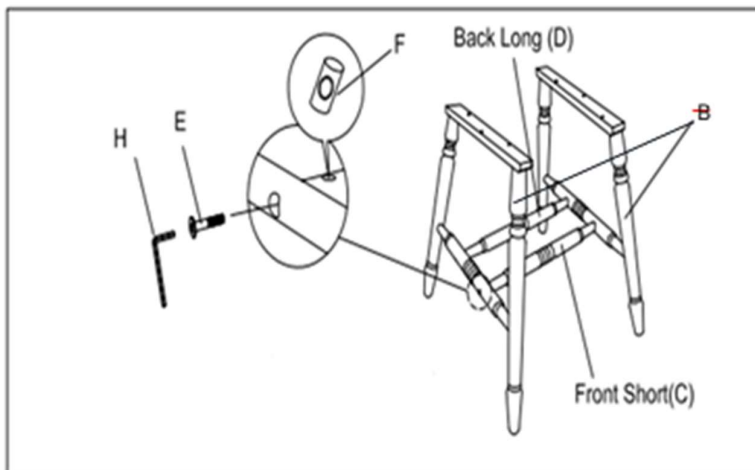

- Attach Stretcher (Long - D) to Leg Frame (B).
- Next, insert Barrel Nut (F) into the designated holes on Stretcher (Short - C) - refer to above for instructions for installing Barrel Nut.
- Insert JCBC Bolt (E) through the bolt hole on (B) as shown to screw into the Barrel Nut in (C). Use Allen Key (H) to drive (E). **Do not tighten (E) completely at this time.**

Step 2

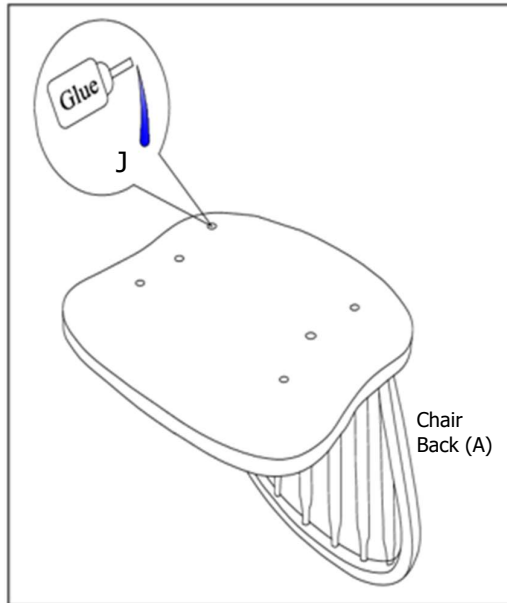

- Set Chair Back (A) Bottom-side up on an elevated surface (eg. Corner of a table top).
- Apply a small amount of Glue (J) to the designated holes as shown.

Step 4

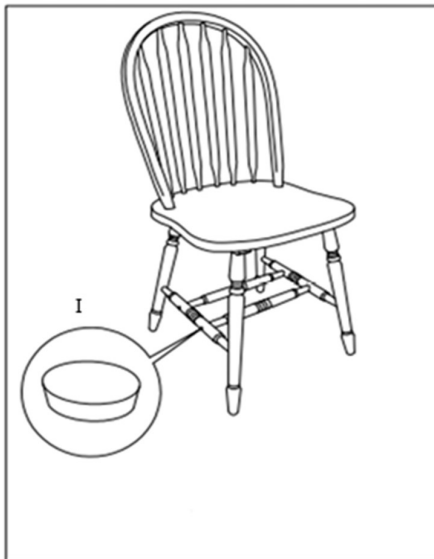

- Set the chair right-side up.
- Tighten JCBC Bolt (E) from STEP 1 completely at this time.**
- Conceal the bolt holes with Wood Button (I).

The assembly of the chair is complete.

Step 3

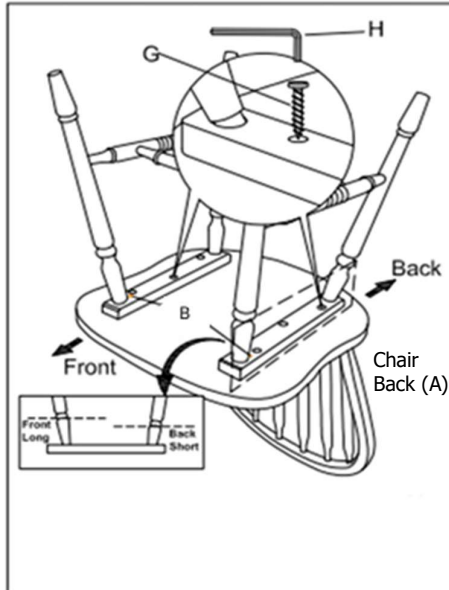

- Position the assembled leg frame from Step 1 as shown with the sticker B facing front of the chair.
- Align the screw holes on the rail of the leg frame to the bolt holes on (A) and fasten with JCBC Screw (G). Use Allen Key (H) to drive and tighten (G). Do not tighten (G) completely until all of the screws are in place. **DO NOT OVERTIGHTEN.**

Important: Check and re-tighten all of the hardware a few days after the product has been assembled and acclimated to its new environment.