

ASSEMBLY INSTRUCTIONS

MODEL: 3466BLK-02 ELEANOR SIDE CHAIR (BLACK)

Please read instructions carefully

Remove all wrapping materials, staples and packing straps from the carton.







Refer to Parts List and Hardware List and ensure they are complete before you start assembling.

Place all wooden parts on a clean, flat and soft surface (e.g carpet or rug) to prevent parts from being scratched.

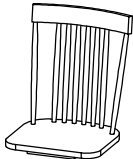
CAUTIONS:1) DO NOT FULLY TIGHTEN BOLTS AND NUTS UNTIL ALL PARTS HAVE BEEN ASSEMBLED.

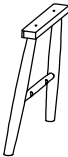
2) DO NOT OVER-TIGHTEN BOLTS AND NUTS .

3) KEEP ALL HARDWARE PARTS OUT OF REACH OF CHILDREN.

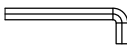
Designation	Part	Qty	Part List	Hardware	Qty	Hardware List
CHAIR BACK	P1	1PC		H1	4PCS	BOLT Ø1/4" x 35mm 
				H2	4PCS	SPRING WASHER Ø5/16" x 13mm 
CHAIR LEGS	P2	2PCS		H3	4PCS	FLAT WASHER Ø5/16" x 19mm 
				H4	4PCS	SCREW Ø4" x 30mm 
CHAIR STRETCHER	P3	2PCS		H5	1PC	ALLEN KEY M4 x 59mm 

COMPLETE ASSEMBLY

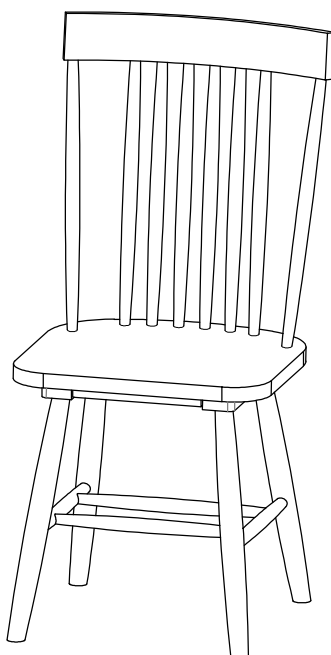

ASSEMBLY INSTRUCTIONS

MODEL: 3466BLK-02 ELEANOR SIDE CHAIR (BLACK)

STEP 1

Prepare the CHAIR BACK (P1) by placing it upside-down. Assemble CHAIR LEGS (P2) by attaching it to the connecting blocks in the CHAIR BACK (P1).

Attach the two CHAIR STRETCHER (P3) into the chair legs and align them into the correct connection holes.

Align BOLT (H1) fitted with a SPRING WASHER (H2) & a FLAT WASHER (H3) through the connecting block holes.

See example image.

Tighten all the bolts with ALLEN KEY (H5).

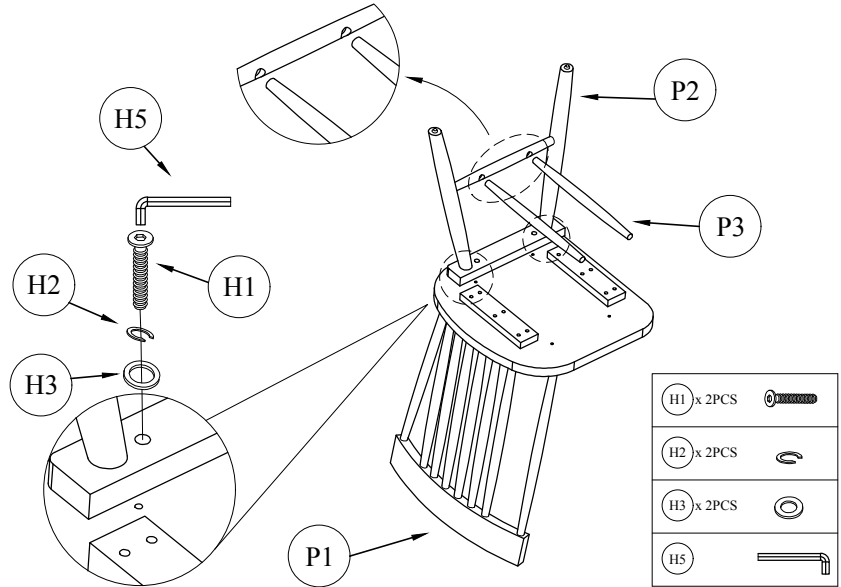

STEP 2

Repeat STEP 1 by assembling the other set of CHAIR LEGS (P2) and attach the CHAIR STRETCHER (P3).

Tighten all the bolts with ALLEN KEY (H5).

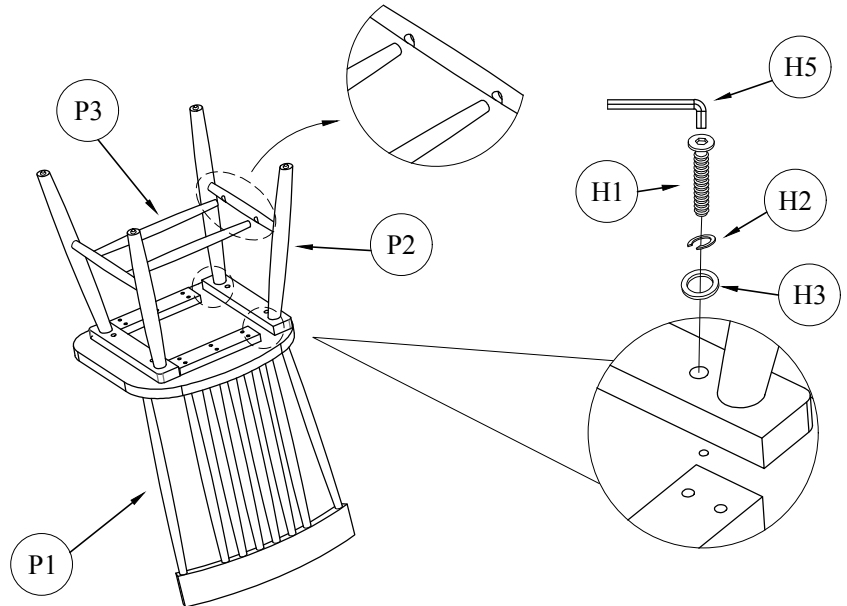

STEP 3

Secure the CHAIR STRETCHERS (P3) to the CHAIR LEGS (P2) with the additional SCREWS (H4) using a Screw Driver (Not provided) and screw them in each corner.

See example image.

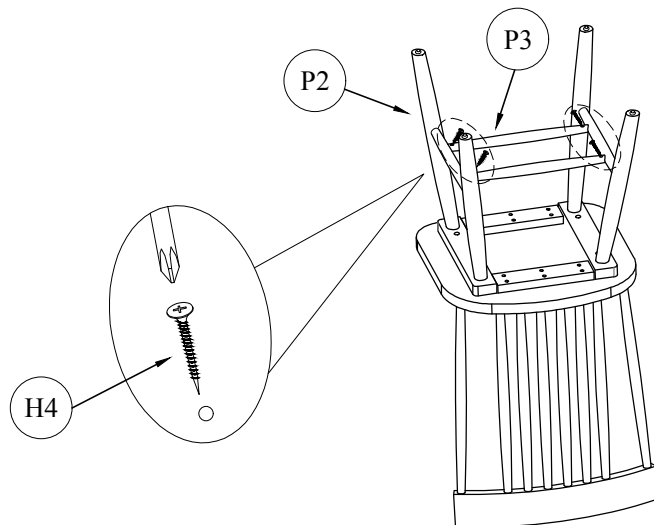

CARE AND MAINTENANCE

SAFETY - To avoid any risk of suffocation to children or animals, dispose off the plastic bags immediately.

CLEANING - Clean with damp cloth and mild detergent. Do not use bleach or abrasive products.

FITTINGS - Tighten bolts and nuts from time to time to ensure all parts of product are securely fitted.