

# Assembly Instructions

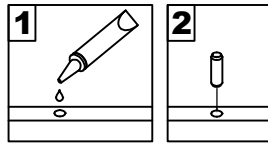

# General Assembly Guidelines

- I. Ensure that all parts and hardware are available before beginning assembly.
- II. Follow each step carefully to ensure the proper assembly of this product.
- III. Two people are recommended for ease in the assembly of this product.
- IV. The three main types of hardware used to assemble this product are : wood dowels , screws and bolts.
- V. The provided glue is to secure wood dowels in place . When first inserting dowels , locate the appropriate hole for the dowel , place a small amount of glue in the hole and insert the dowel . Wipe away excess glue immediately.



In future assembly steps when dowels are necessary to attach assembly parts together , place a small amount of glue on the end of the dowel before attaching parts together . Wipe away excess glue immediately.

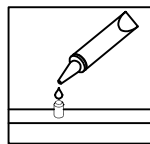

- VI. A Phillips head screwdriver is required for the assembly of this product .

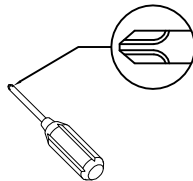

- VII. Power tools should not be used to assemble this product .

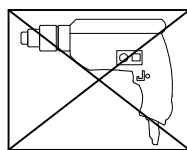

- VIII. Concealed hinges are three-way adjustable.

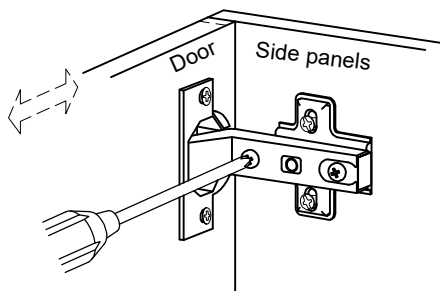

Horizontal  
by screw adjustment

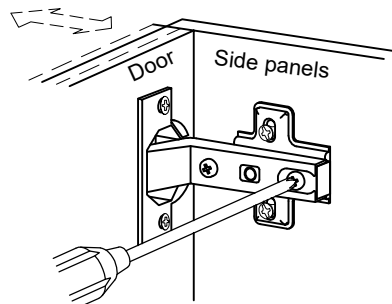

In-and-Out  
by loosening the hinge-arm  
mounting screw or via cam  
adjustment

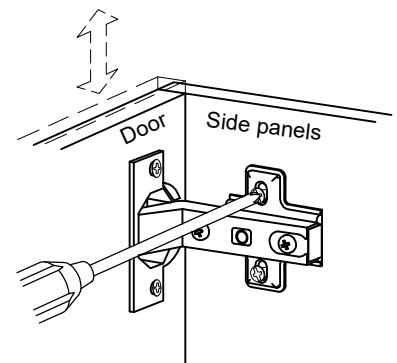

Vertical  
Via slots in the mounting  
plate or via cam adjustment



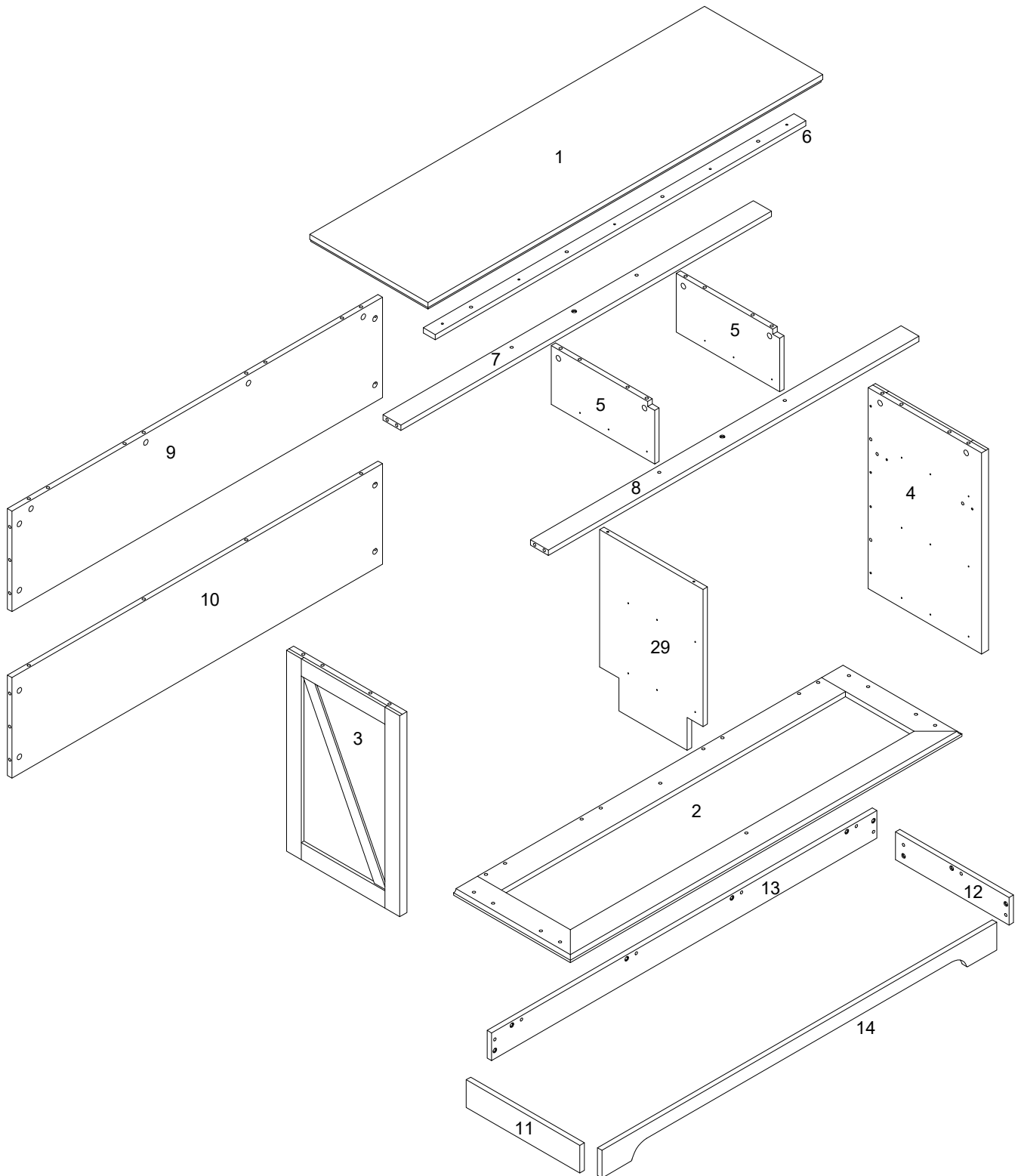



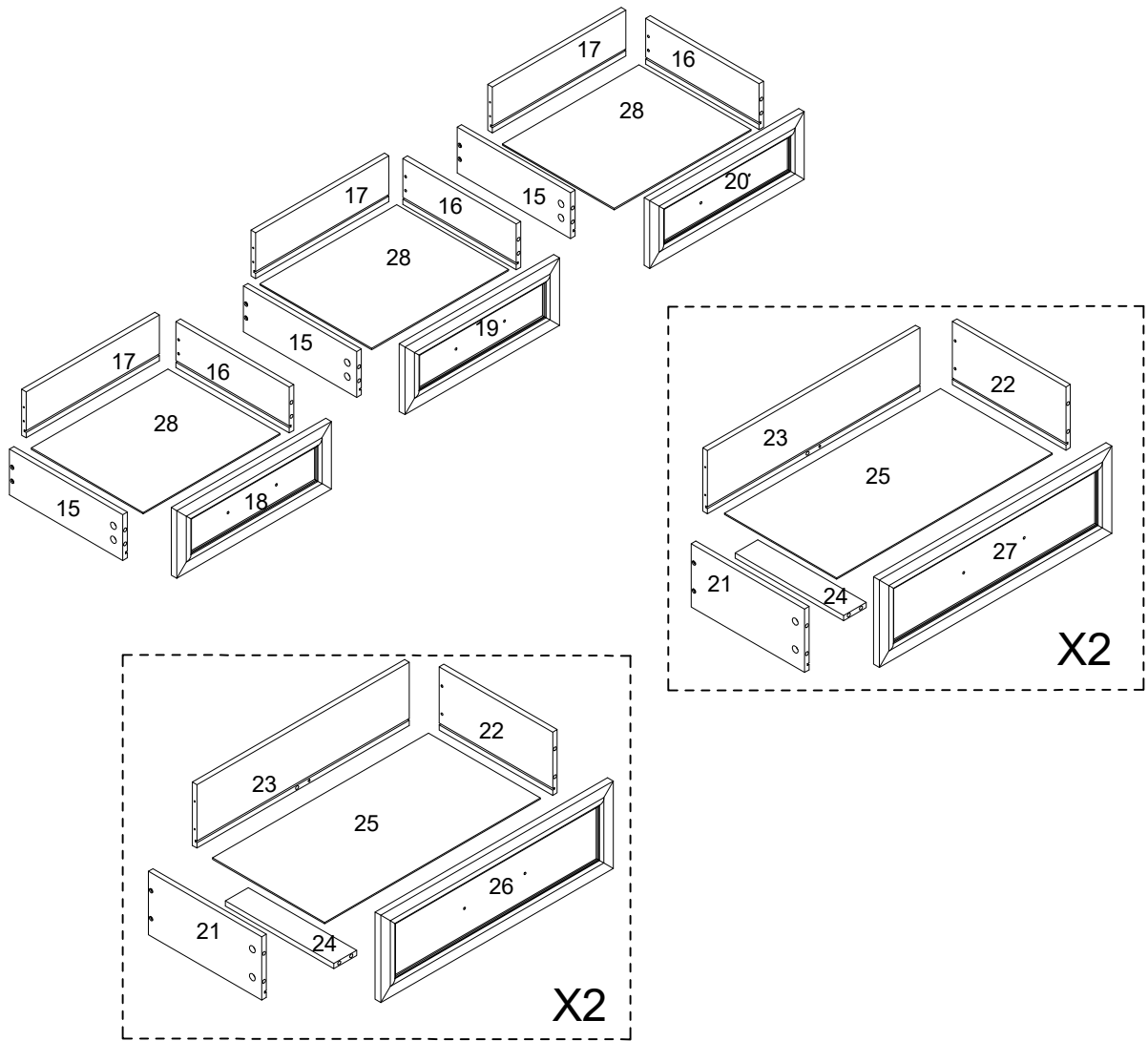





# Parts List

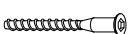

# Parts List

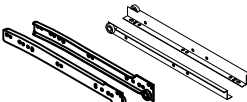

# Hardware List

A		Ø8x30mm	Wooden dowel	40 pcs
B		Ø6x35mm	Cam lock	56 pcs
C		Ø15x11mm	Cam lock	24 pcs
D		Ø15x9mm	Cam lock	32 pcs
E		Ø30mm	Sticker	56 pcs
F		Ø6x50mm	Bolt	16 pcs
G		M 4	Hex Key	1 pc
H		M6*12mm	Screw	28 pcs
I			Angular Code	14 pcs
J		Ø4x32mm	Screw	32 pcs
K		Ø4x25mm	Screw	5 pcs
L		Ø8x20mm	Wooden dowel	4 pcs
M		Individually packed	Drawer slides	7 Set
N		Ø3x12mm	Screw	84 pcs

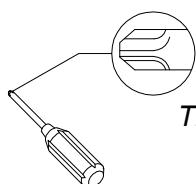

Philips head screwdriver required for assembly  
(not included)

*The hardware quantities listed above are required for proper assembly.  
Some extra hardware may also have been included.*

# Hardware List

Q		128mm	Hold hands	3 pcs
R		160mm	Hold hands	4 pcs
S		Ø4x9mm	Screw	14 pcs
T			Anti-inversion hardware	4 pcs
U		Ø4*15mm	Screw	4 pcs
V			House lizard	4 pcs
W		Ø4x35mm	Screw	4 pcs
X			Strip	2 pcs
Y			Small White Glue	2 pcs

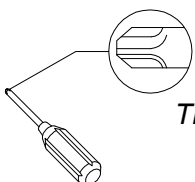



Philips head screwdriver required for assembly  
(not included)

*The hardware quantities listed above are required for proper assembly.  
Some extra hardware may also have been included.*

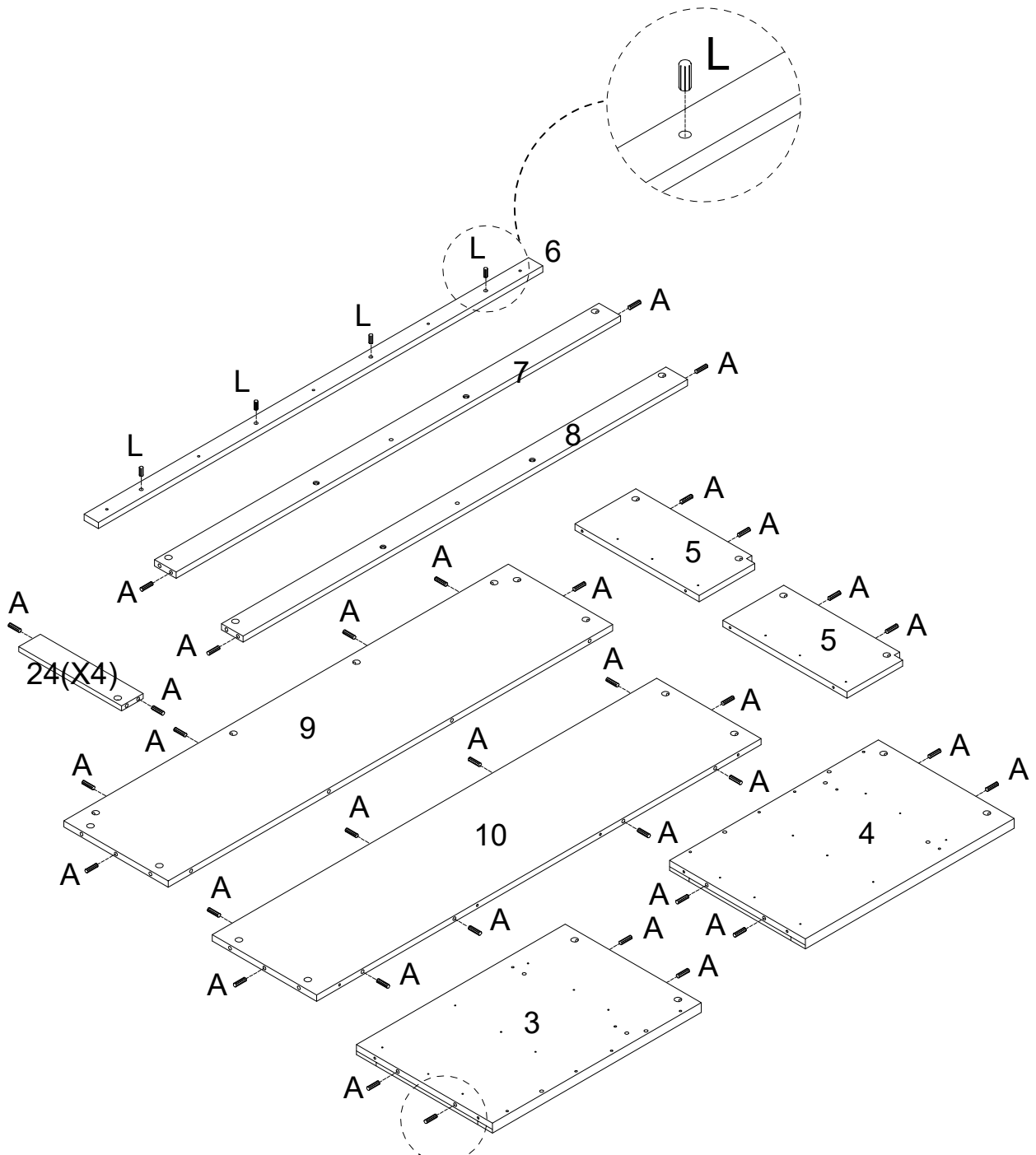
# Step 1



L	A
	
X4	X40



# Step 3

## M-CL<sub>8</sub>



## M-CR<sub>8</sub>

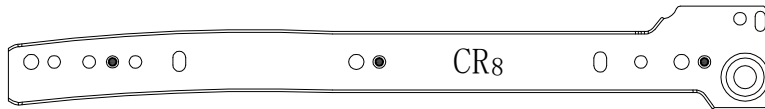

## M-DL<sub>8</sub>

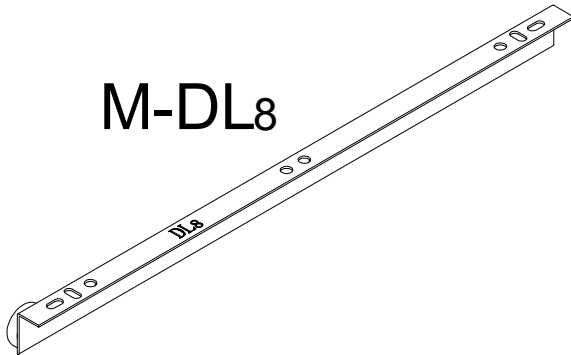

## M-DR<sub>8</sub>

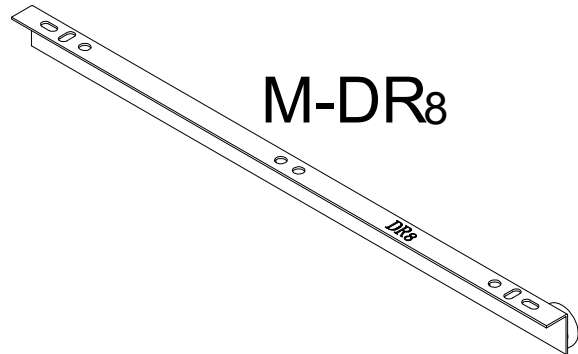

# Step 4

**NOTE:**



Refer to the images to identify M-CL8 (left) and M-CR8 (right). Attach M-CL8 to #3 panel and M-CR8 to #4 panel. [R] screws must go in the exact spots shown.

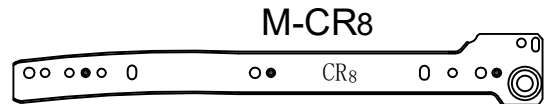
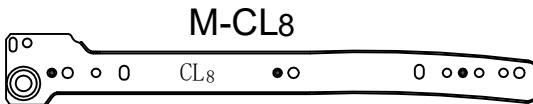

Make sure the rollers on the slides face downward.

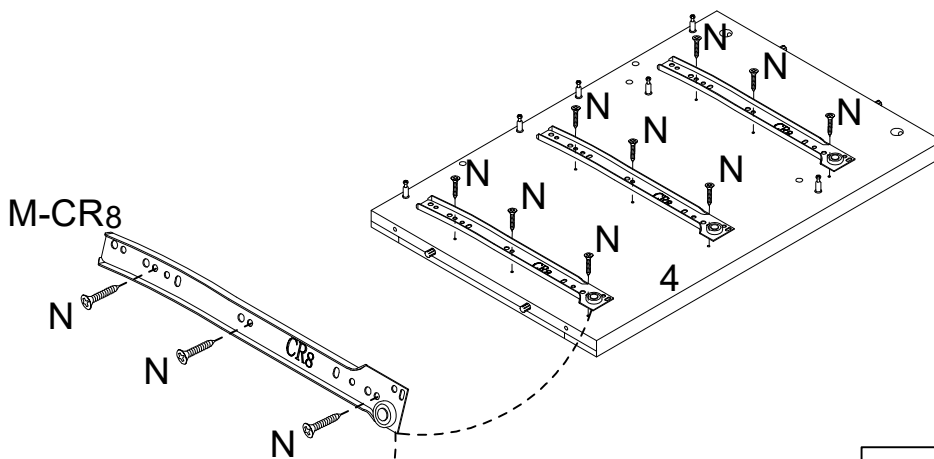
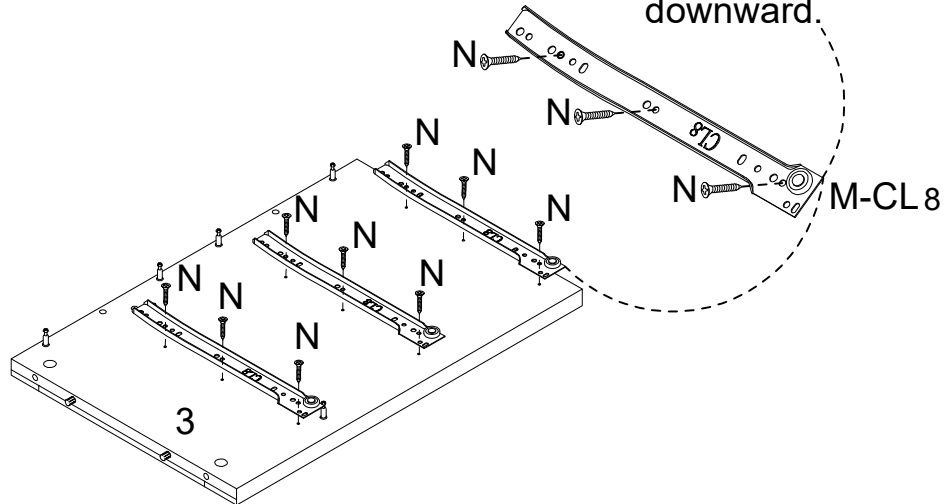

Make sure the rollers on the slides face downward.

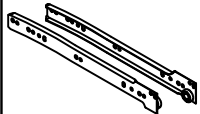
N	M
	
X18	X3

# Step 5

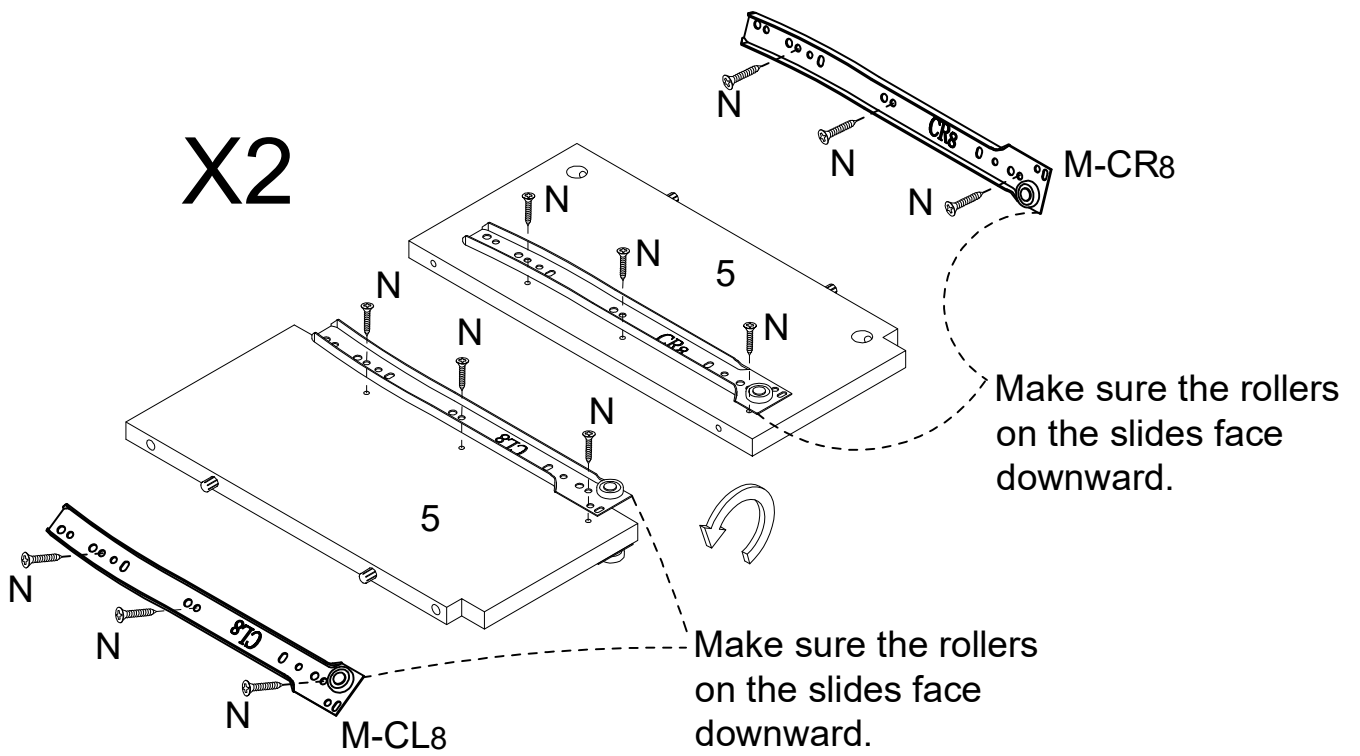

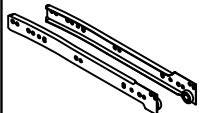
N	M
	
X12	X2

# Step 6

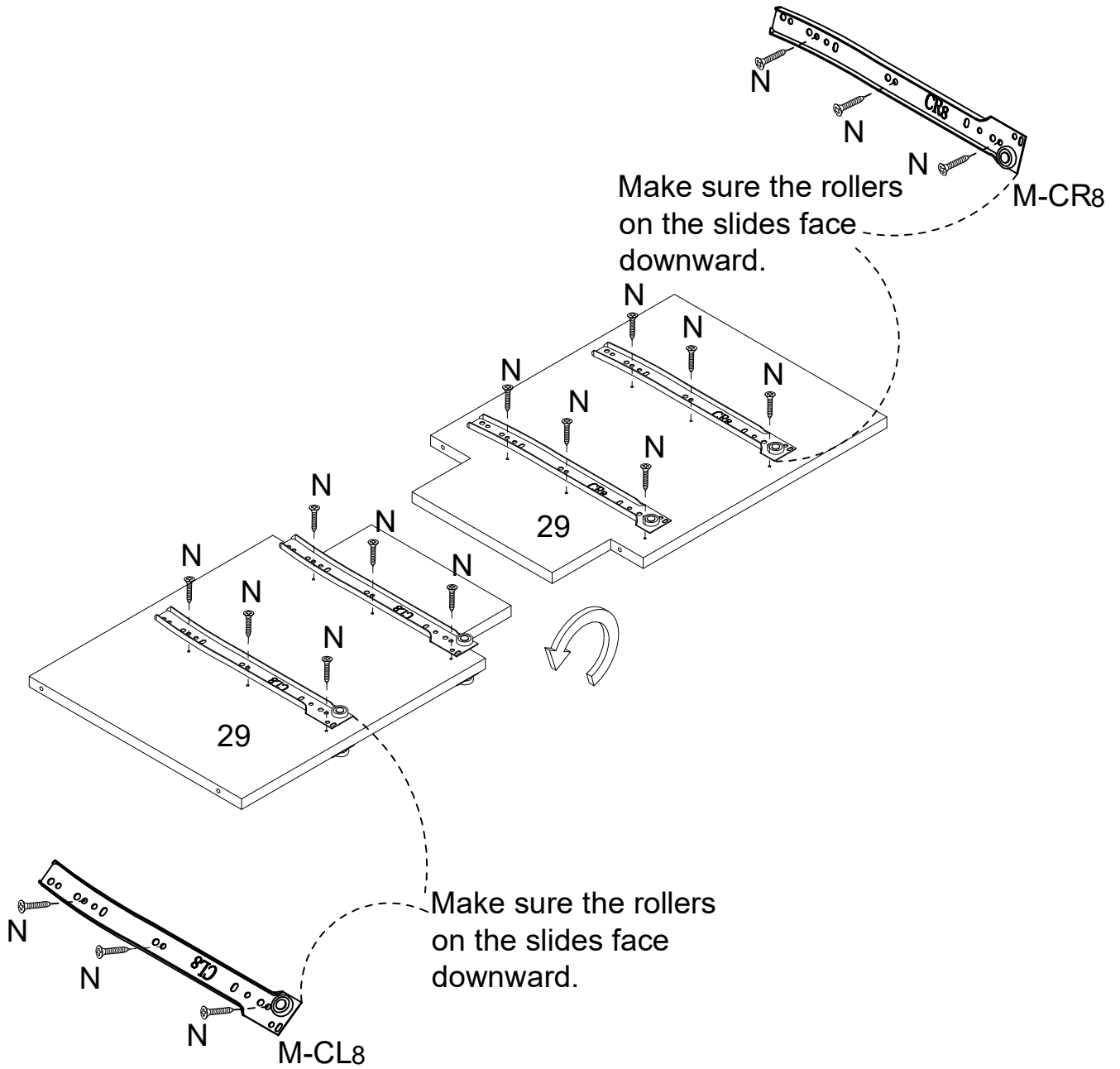

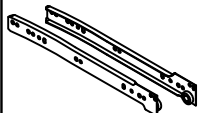

N	M
	
X12	X2

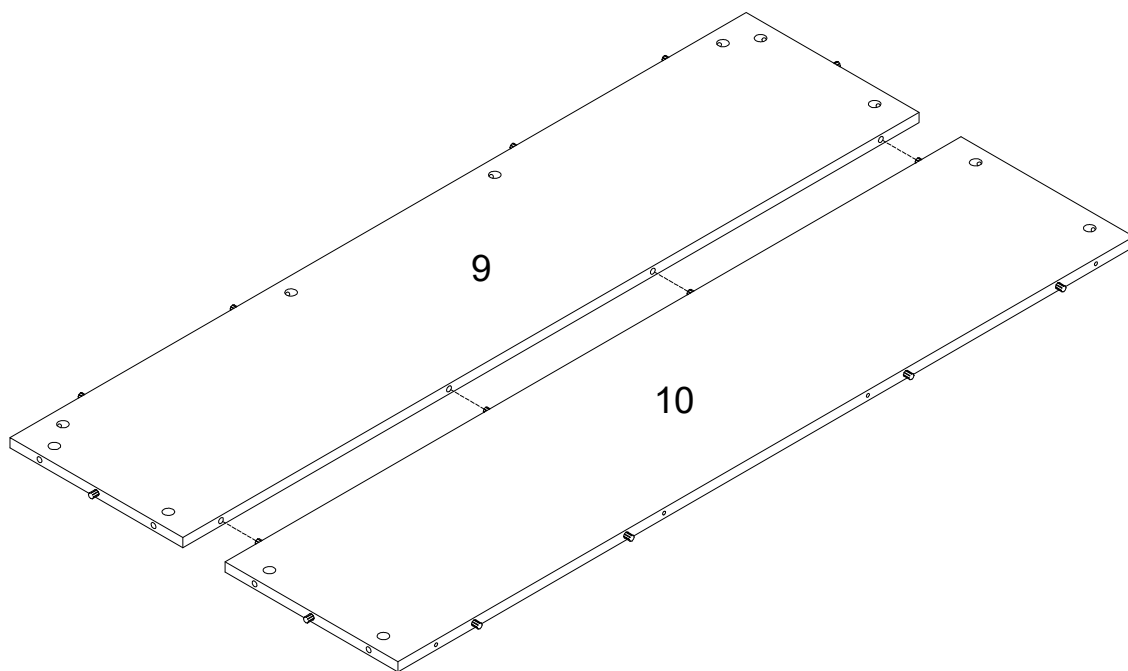
# Step 7



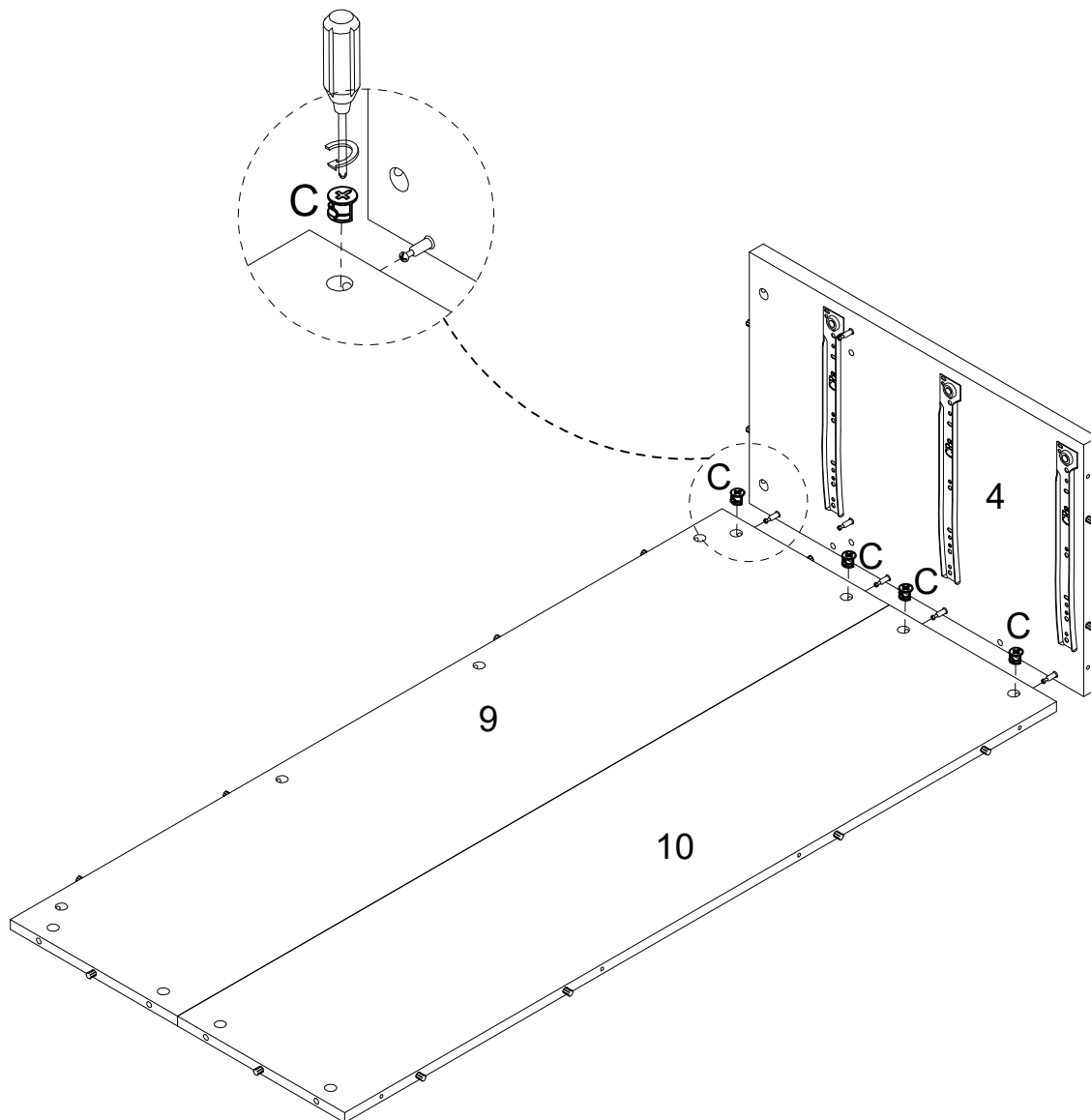
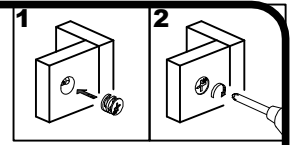

# Step 8

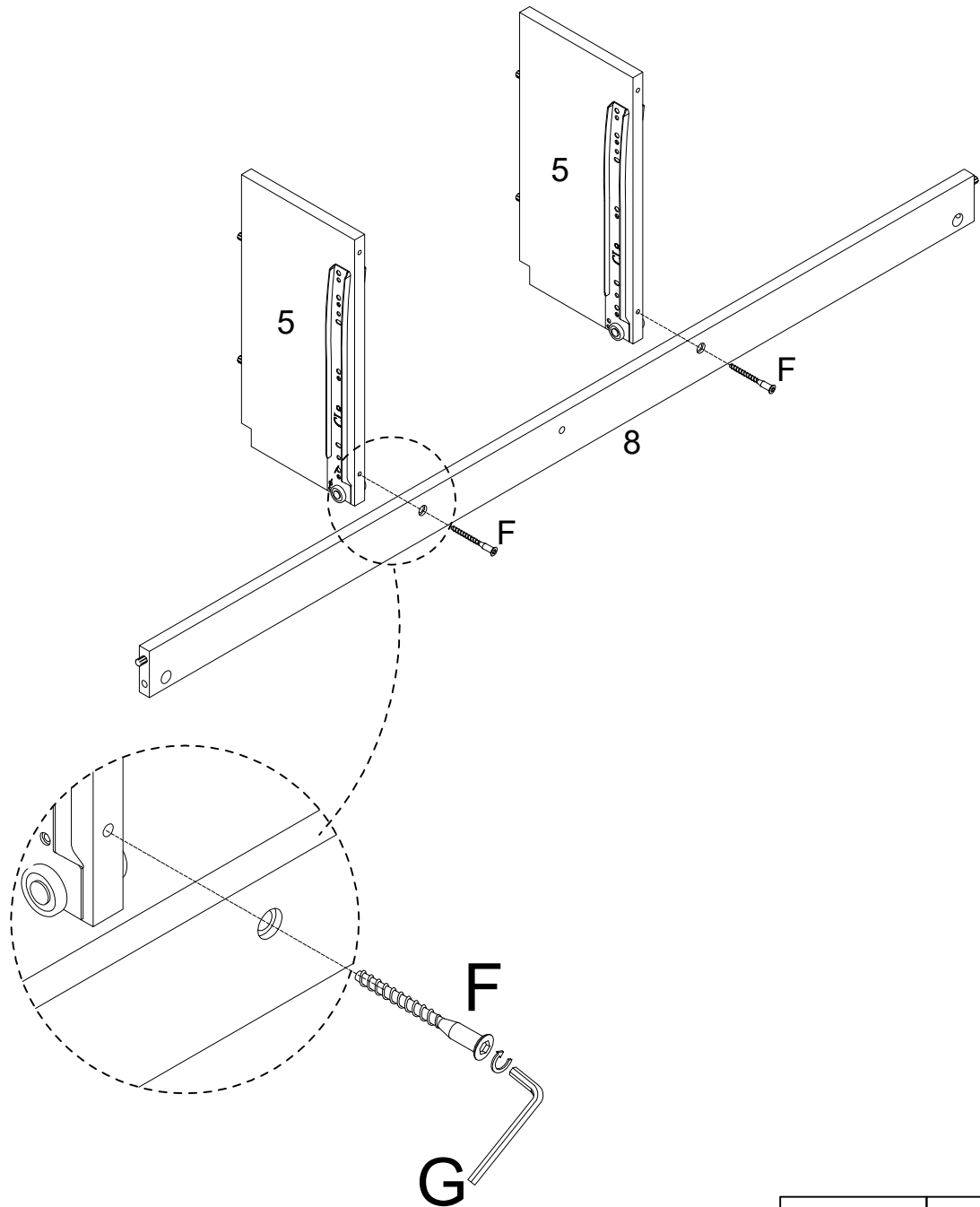

C

X4

# Step 9

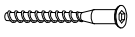

G	F
	
X1	X2

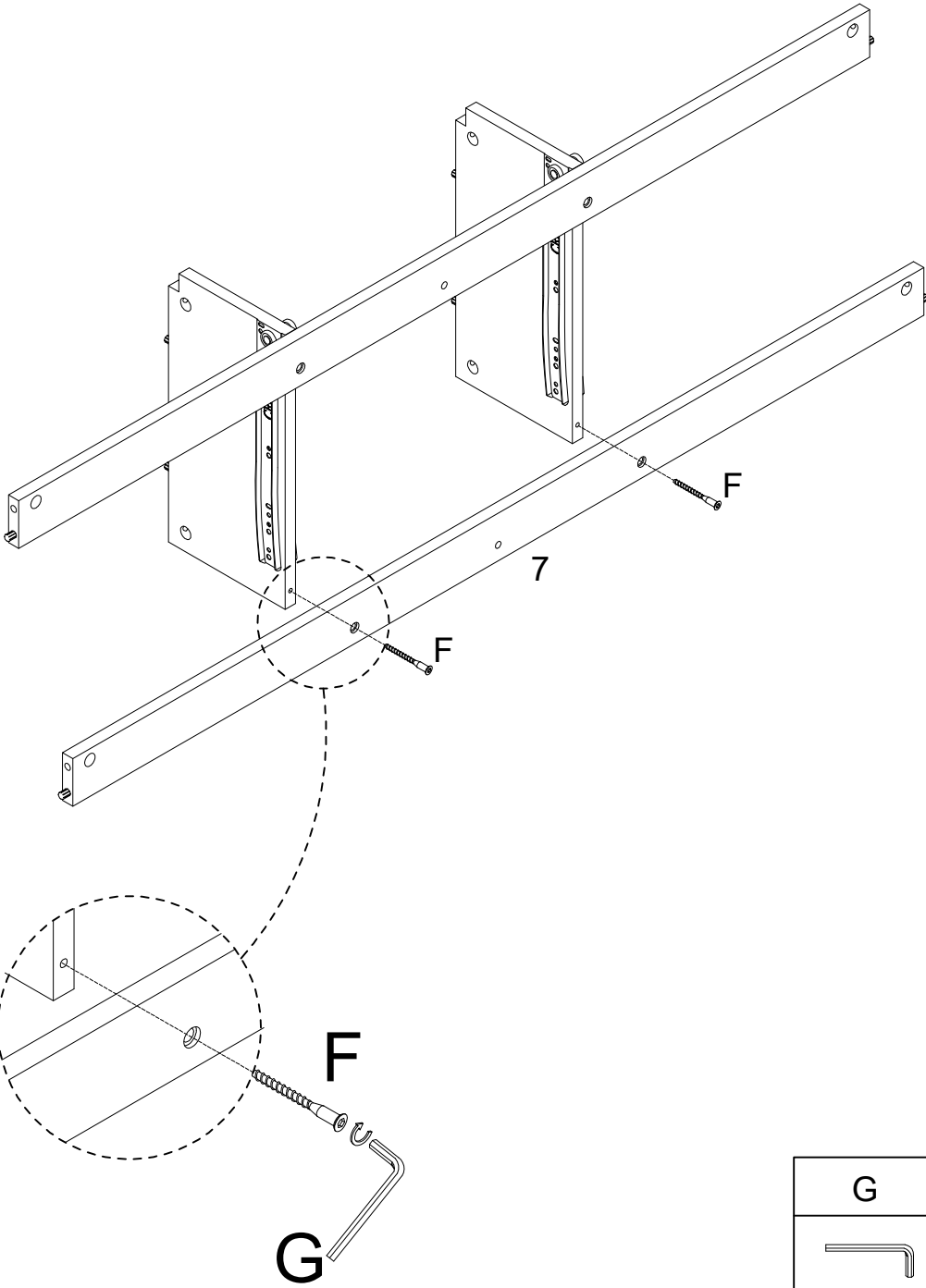
# Step 10

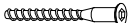

G	F
	
X1	X2

# Step 11

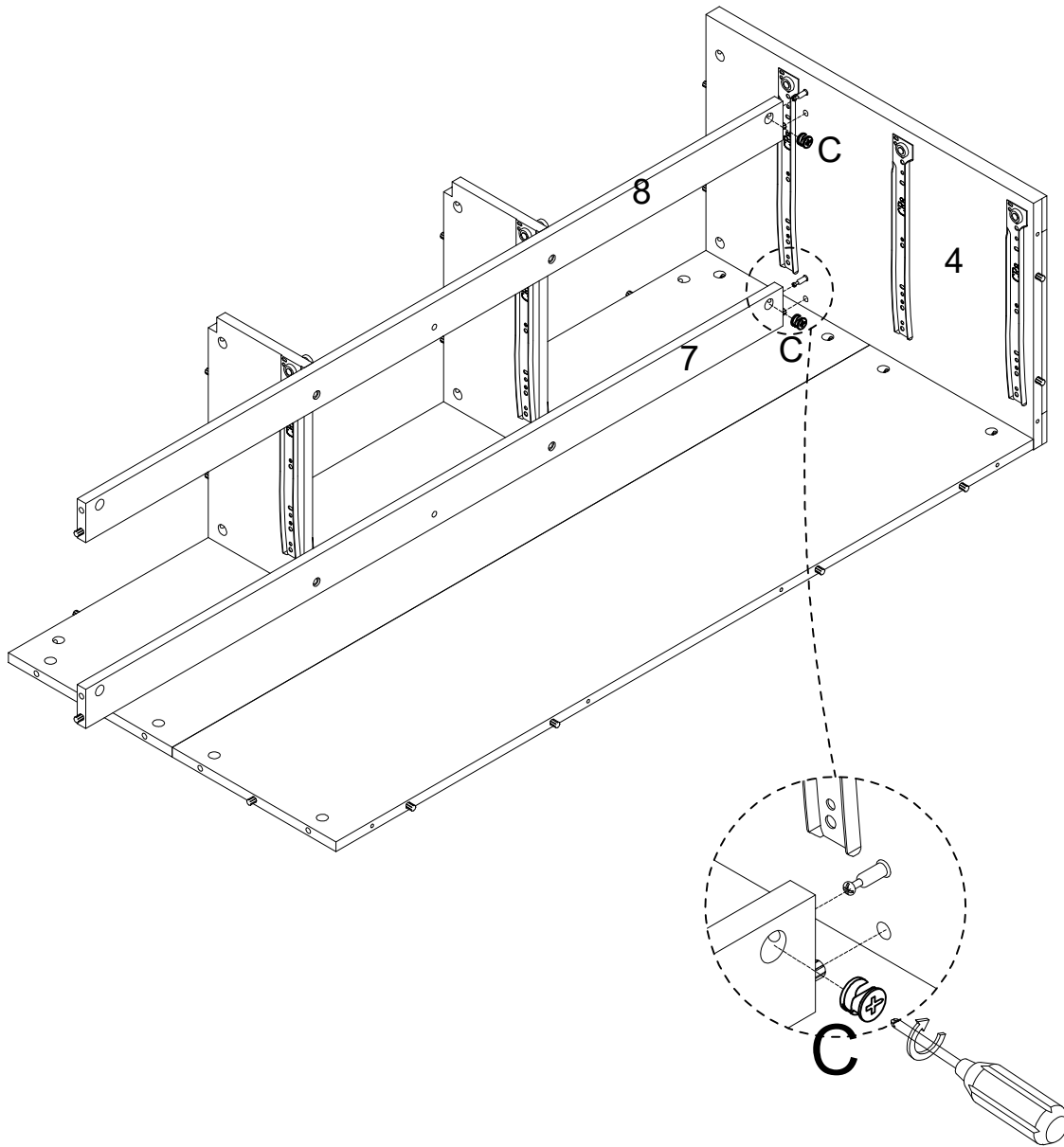
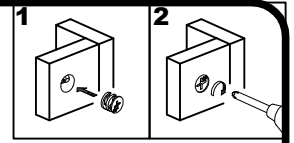

C

X2

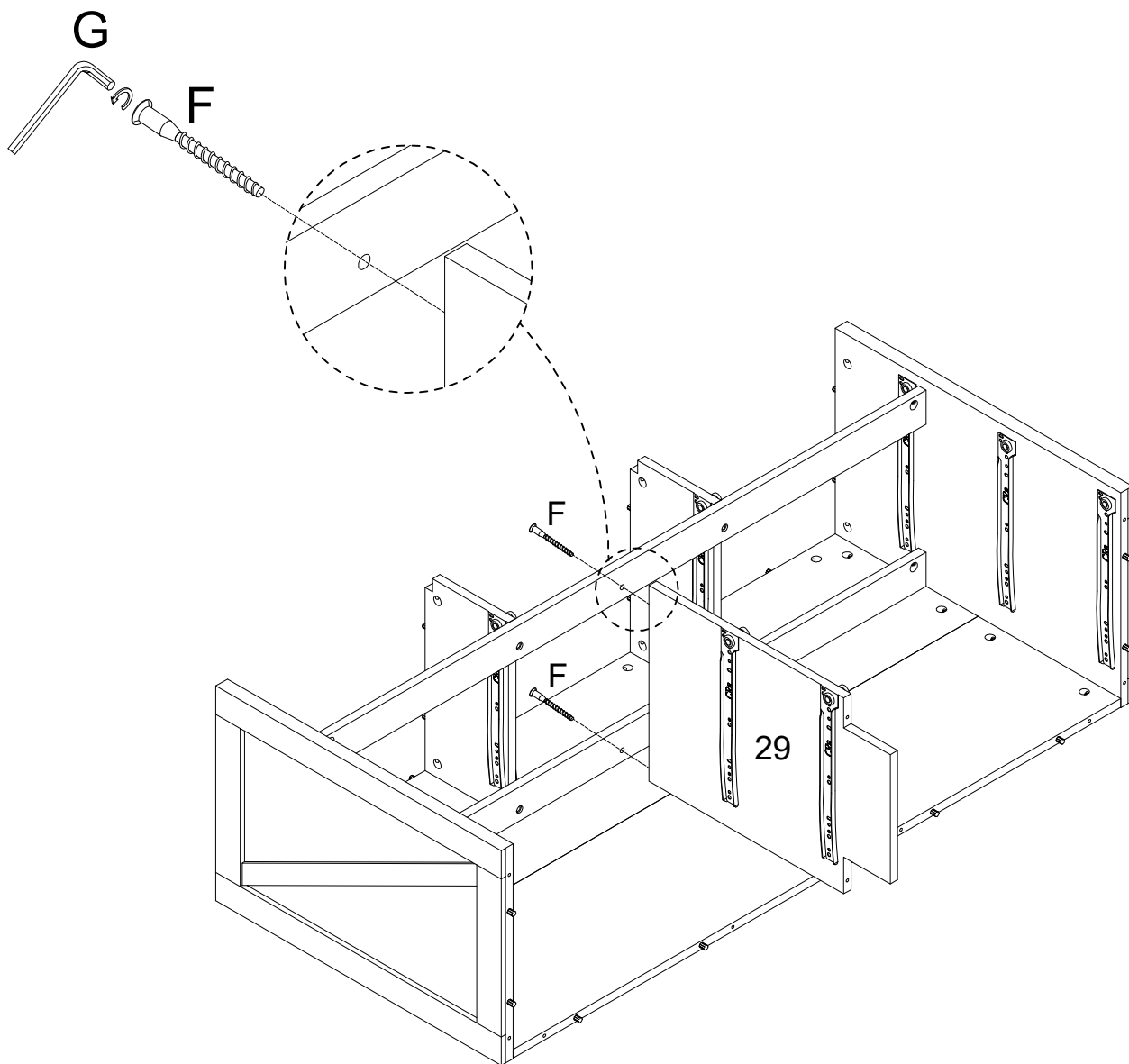

# Step 13

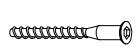



G	F
	
X1	X2



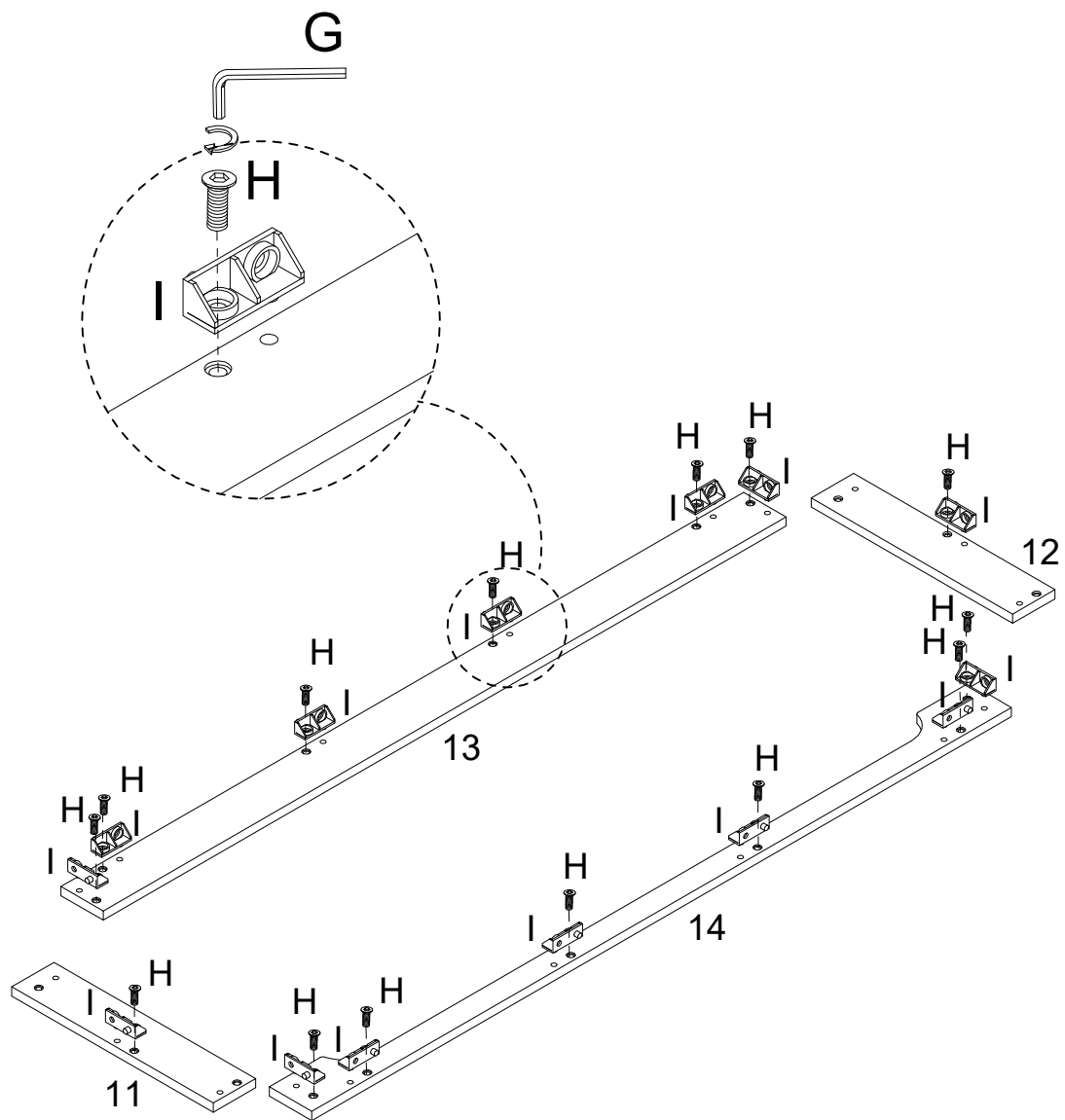

# Step 15



G	I	H
		
X1	X14	X14

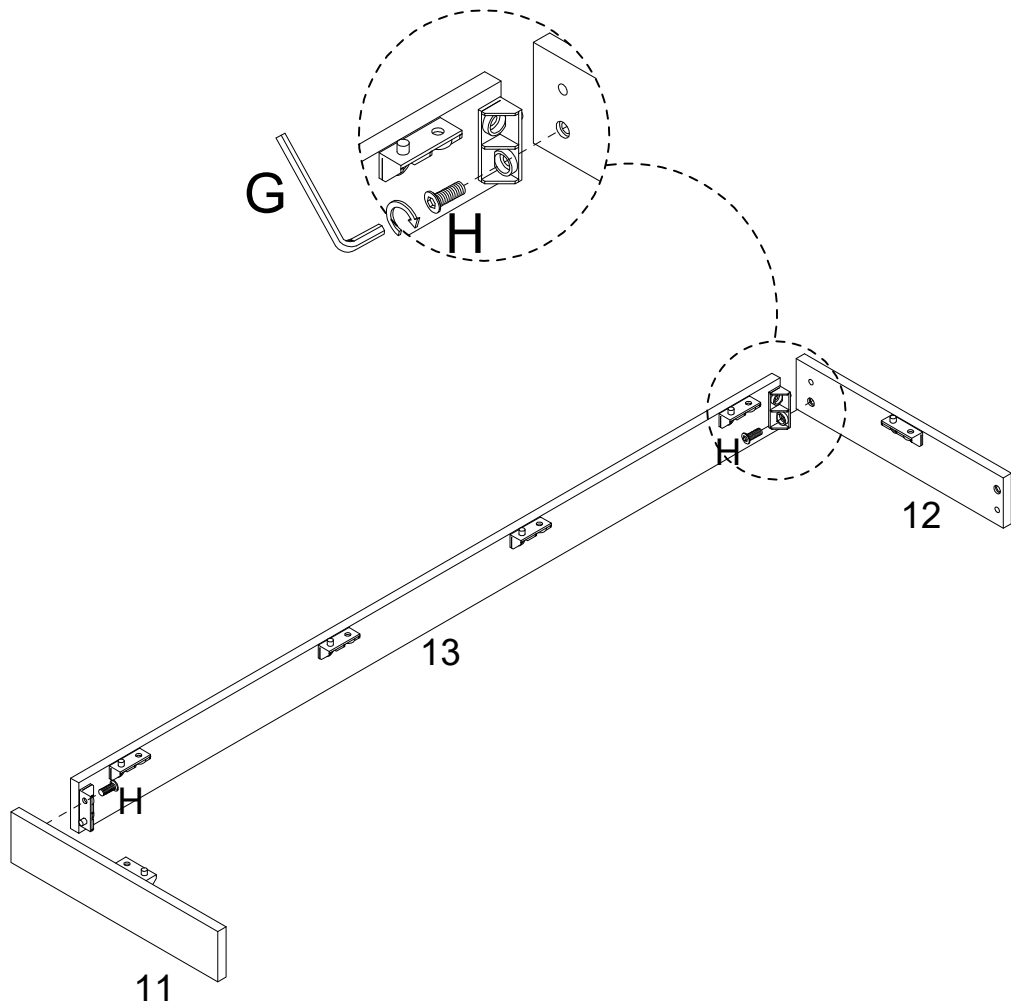

# Step 16



G	H
	
X1	X2

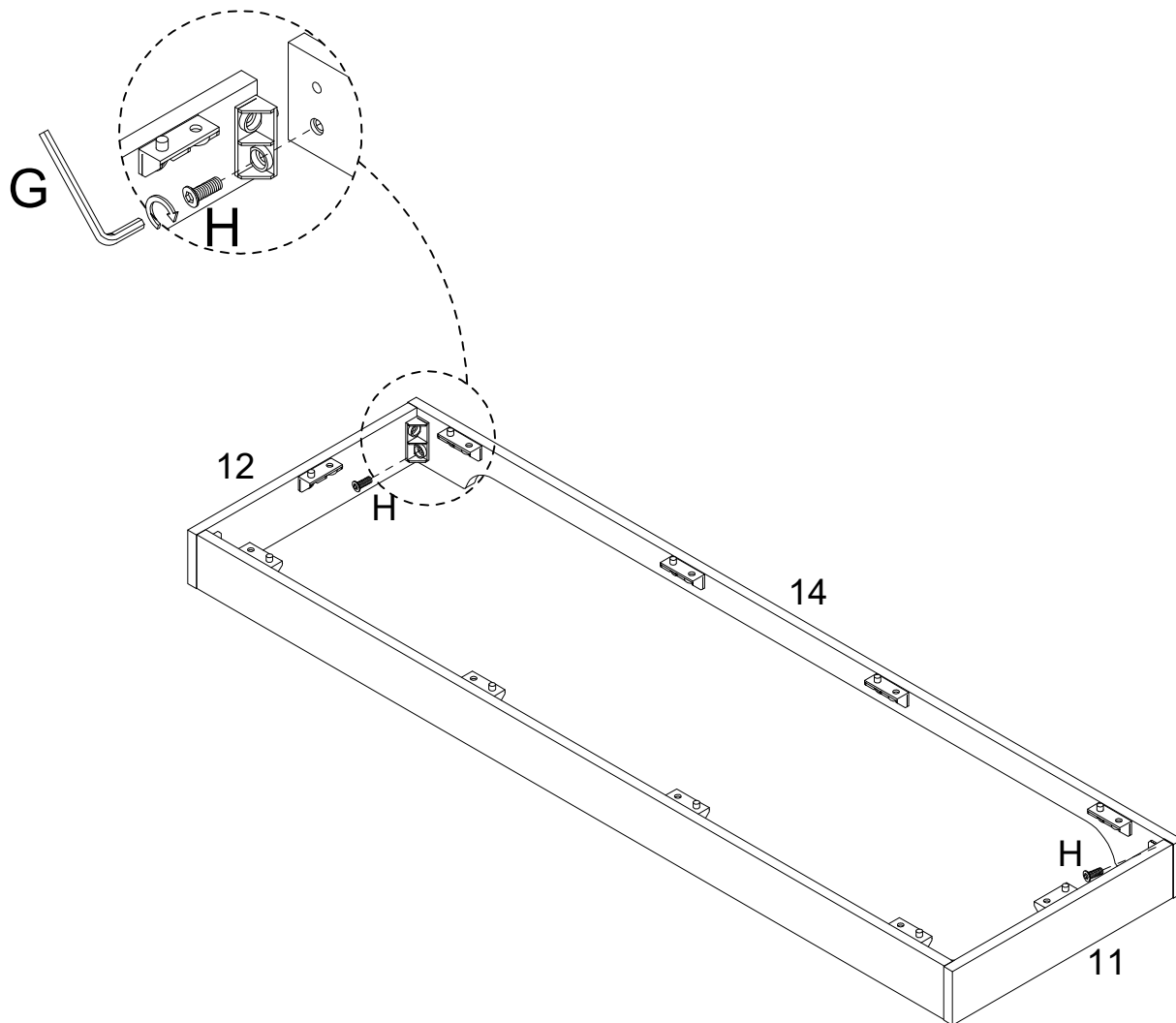

# Step 17

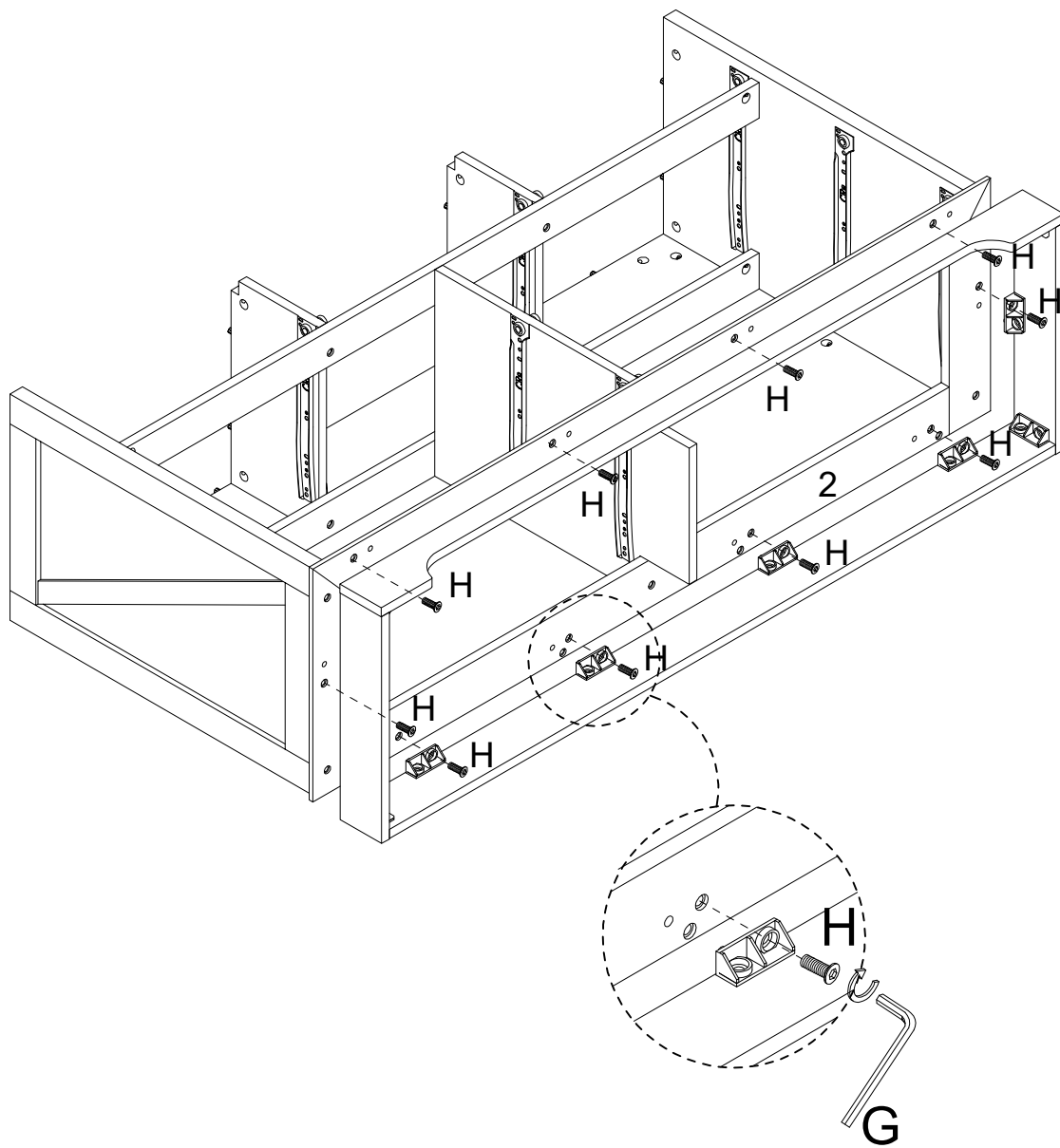

G	H
	
X1	X2

# Step 18



G	H
	
X1	X10

# Step 19

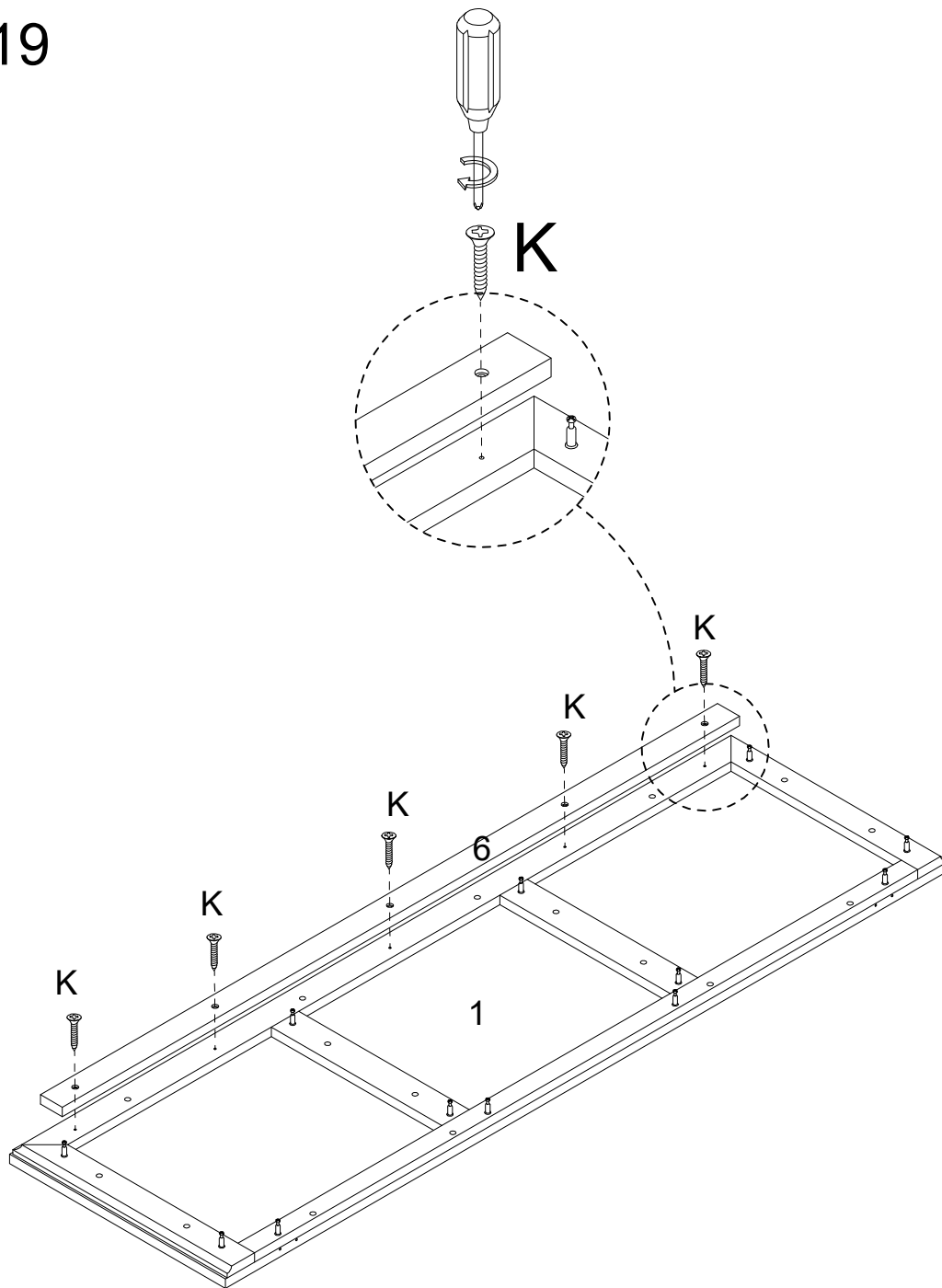

K

X5

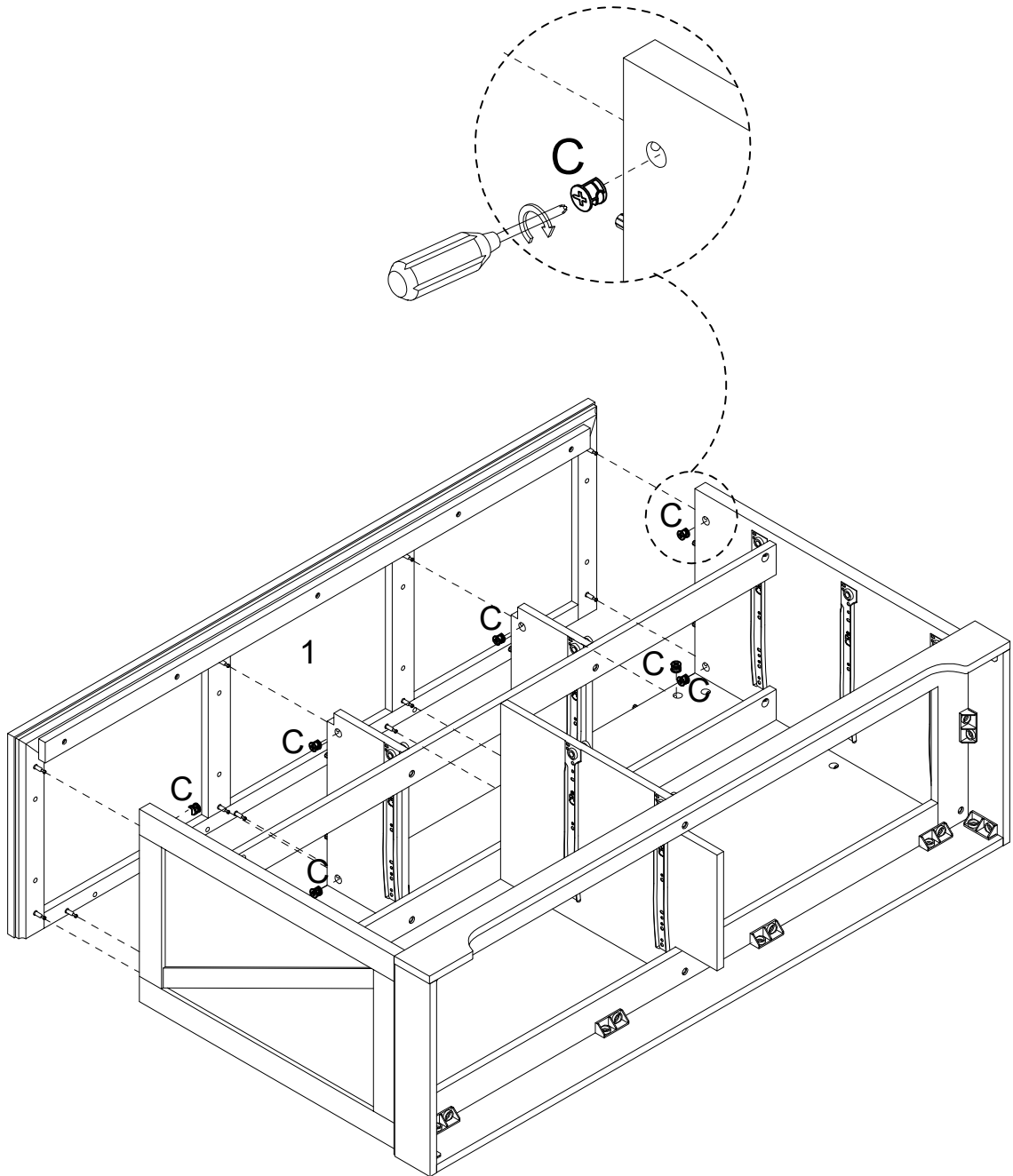
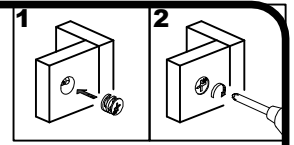
# Step 20

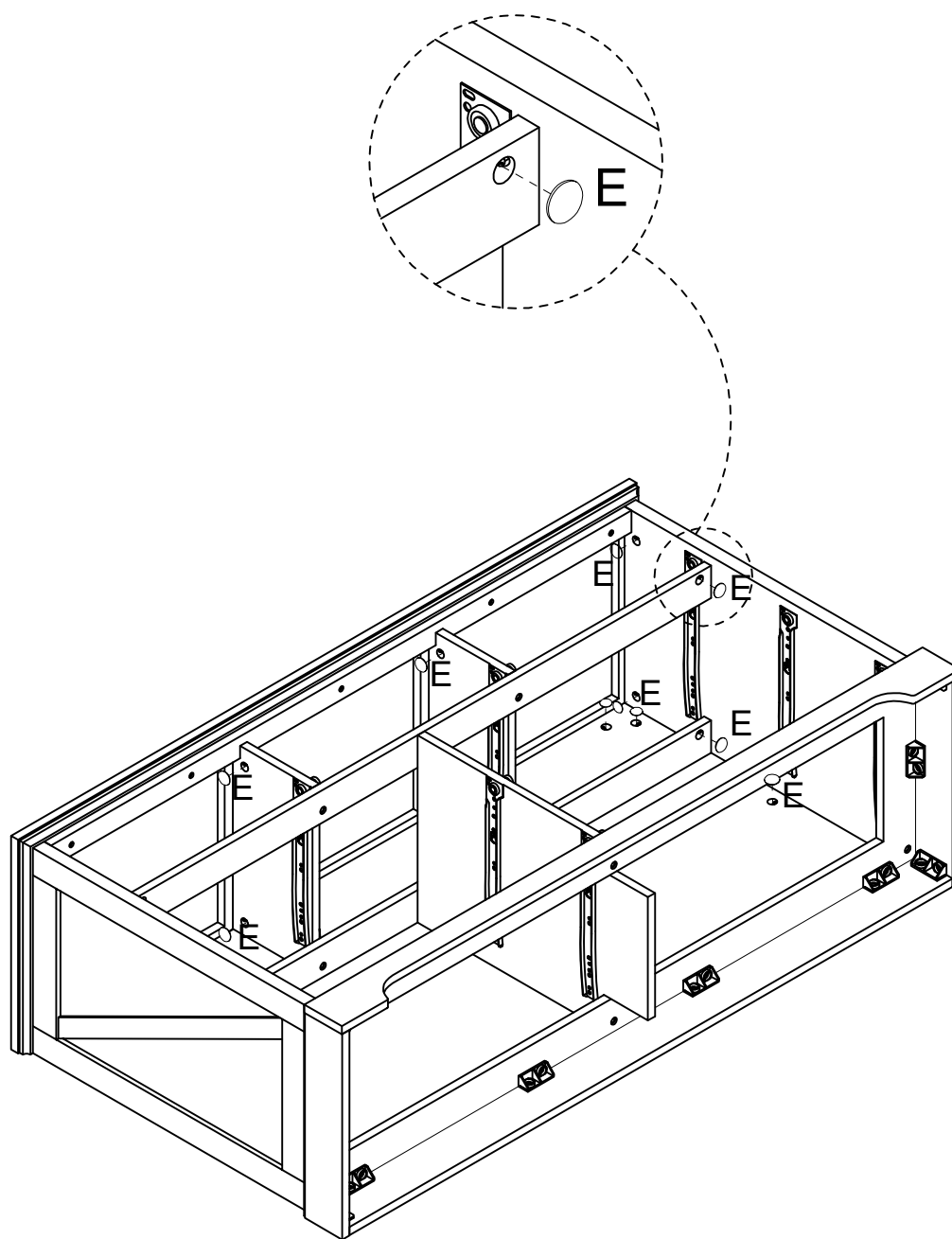

C

X12

# Step 21

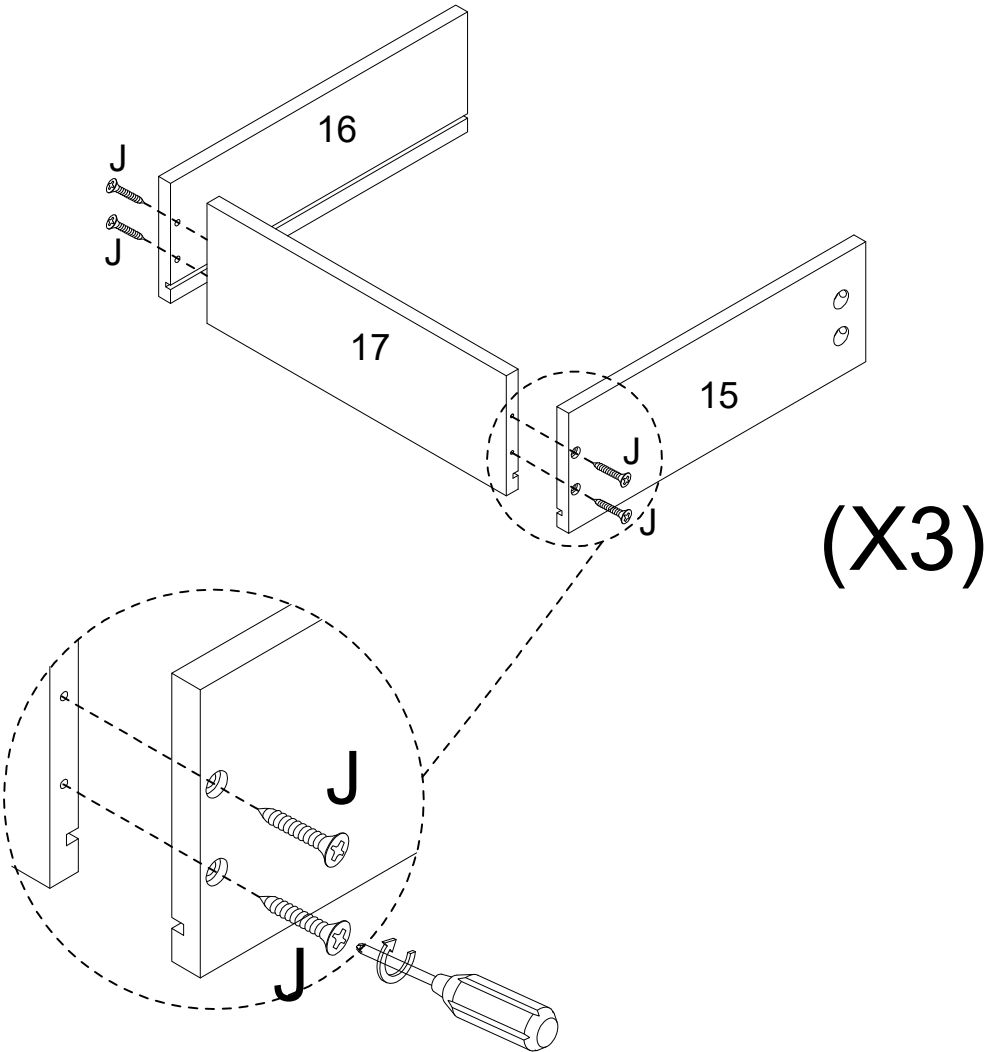

E
○
X24

# Step 22



J

X12

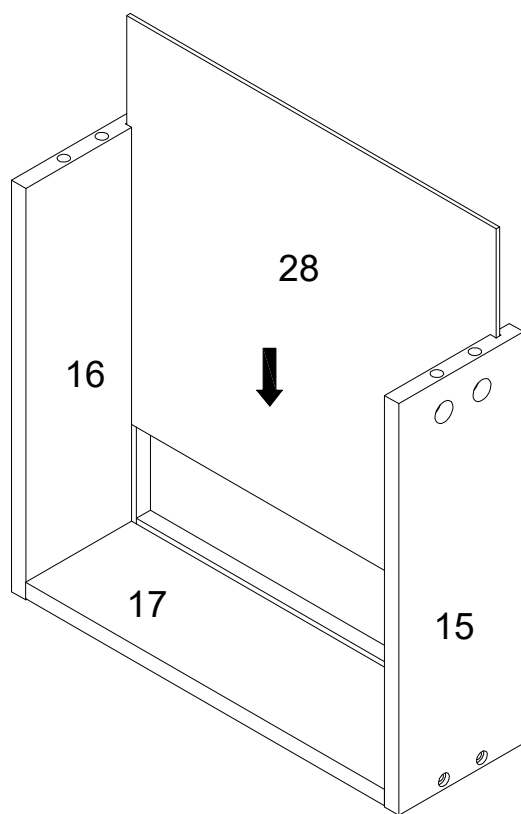
# Step 23



(X3)



# Step 25

NOTE:



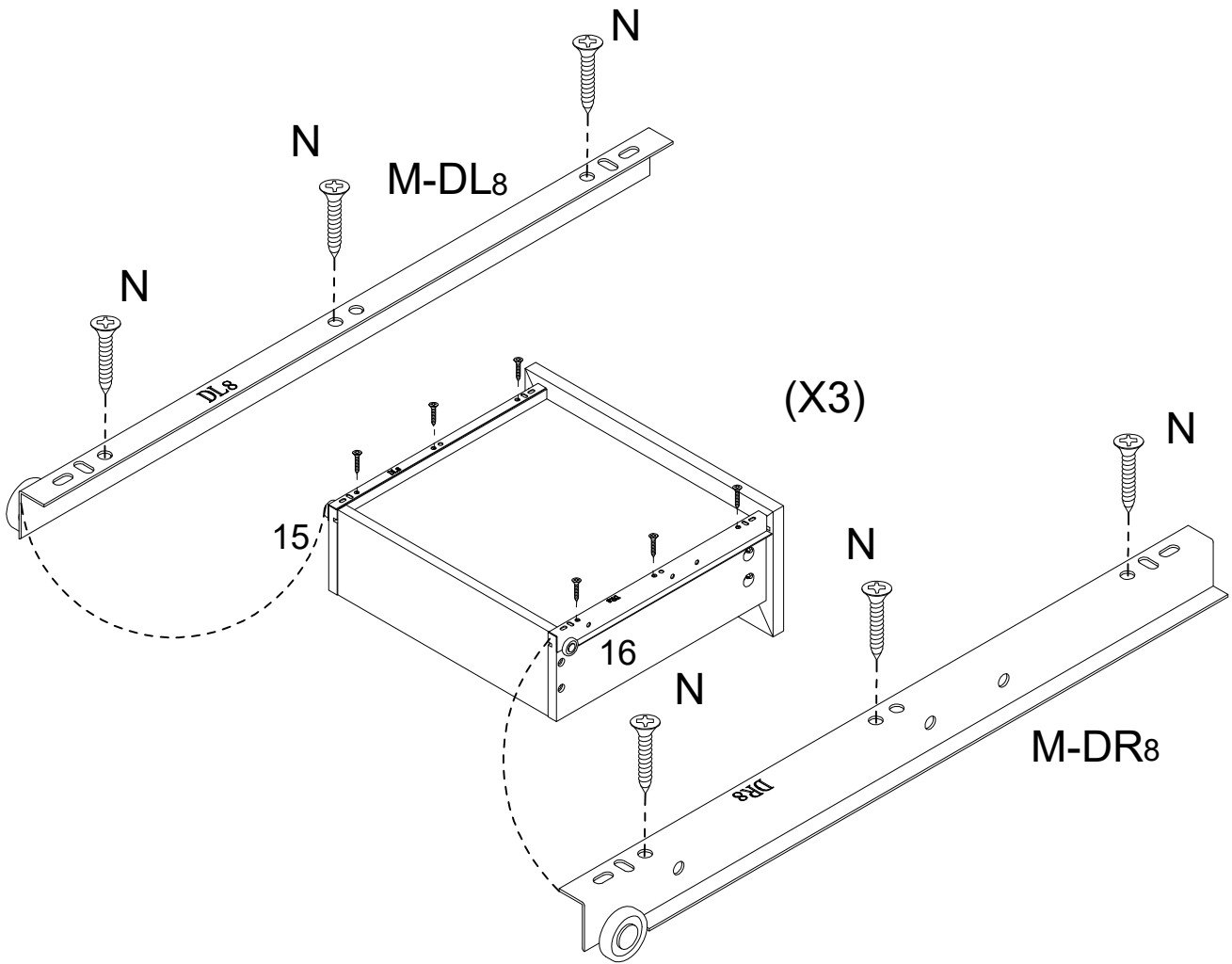

Refer to the images to identify M-DL8 (left) and M-DR8 (right). Attach M-DL8 to #15 panel and M-DR8 to #16 panel. [R] screws must go in the exact spots shown.

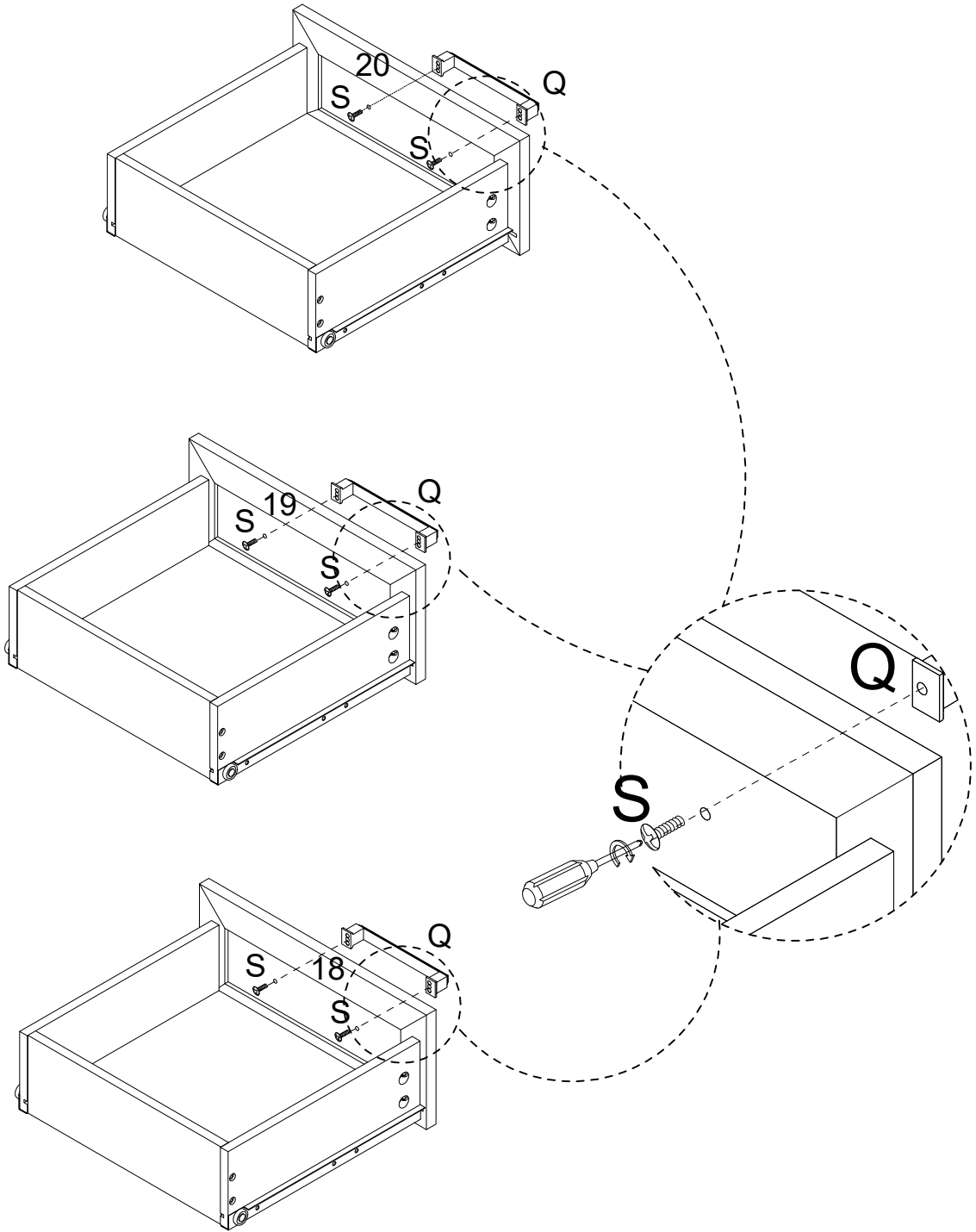

N	M
X18	X3

# Step 26



S	Q
	
X6	X3

# Step 27

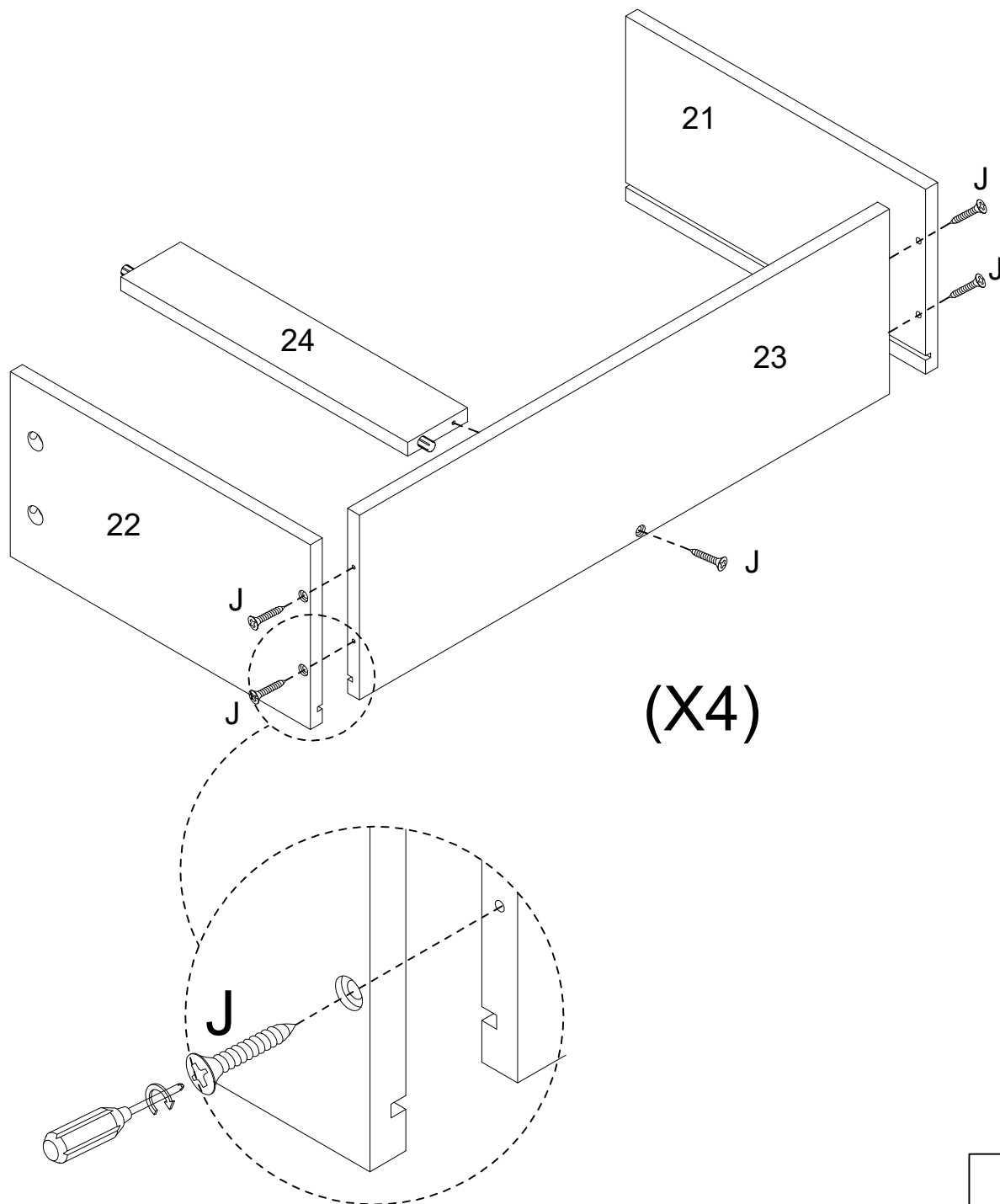

(X4)

J

X20

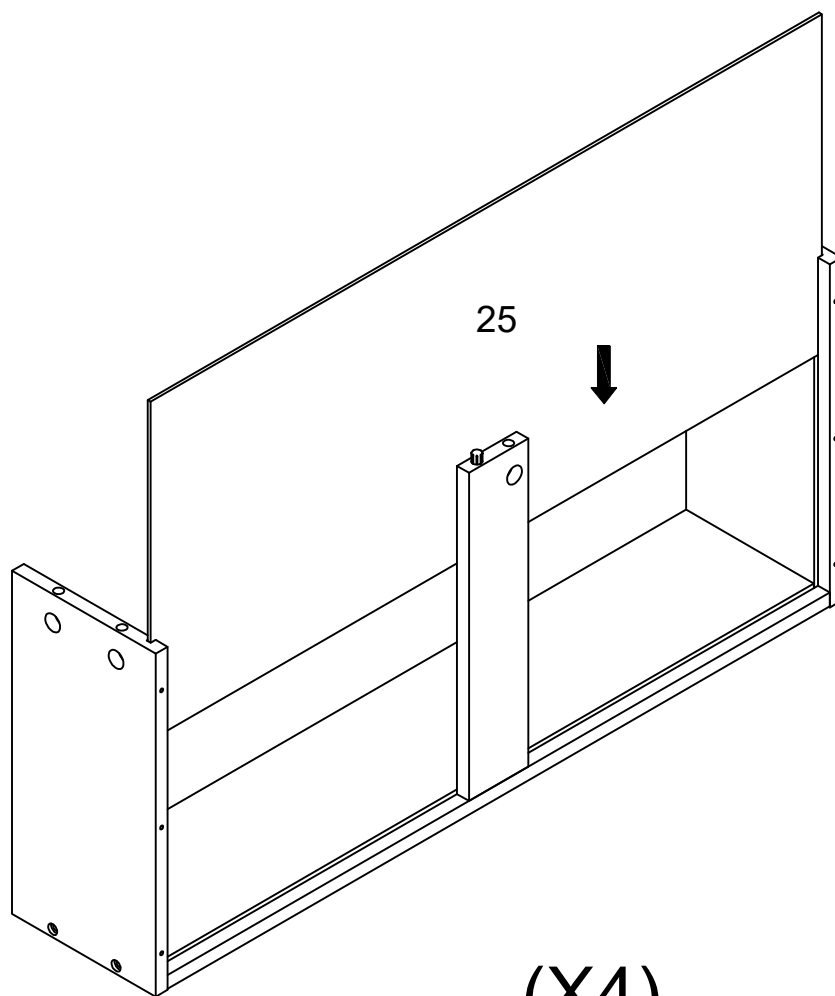
# Step 28

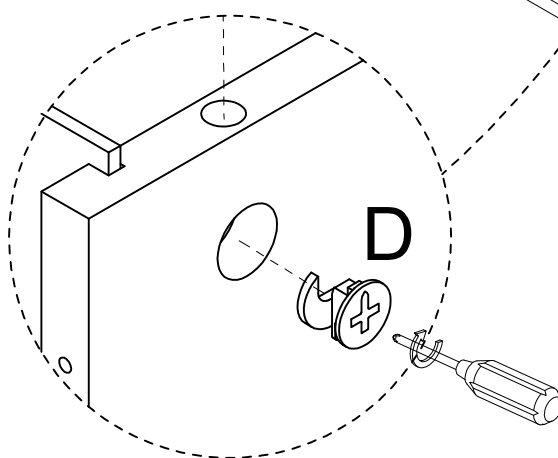
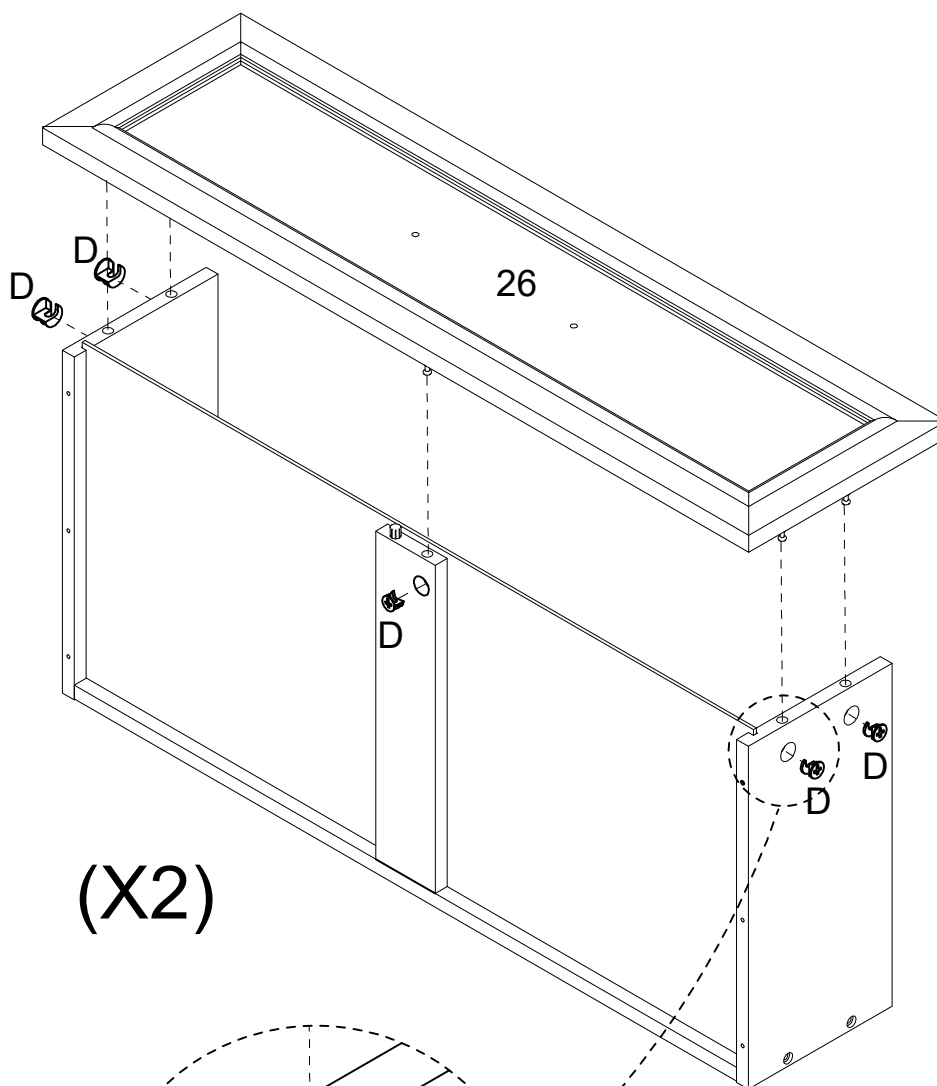
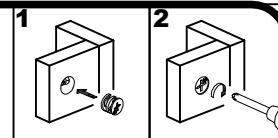

(X4)

# Step 29



D

X10

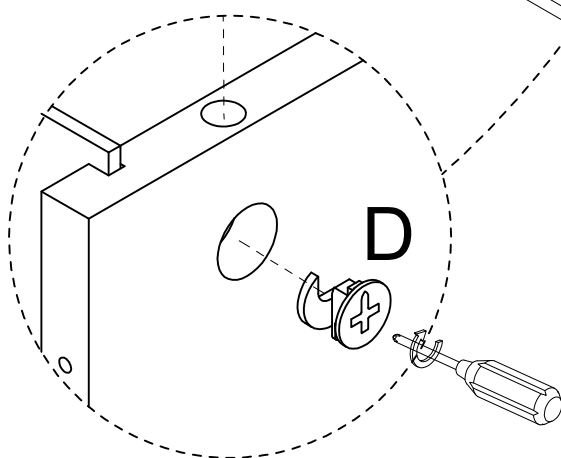
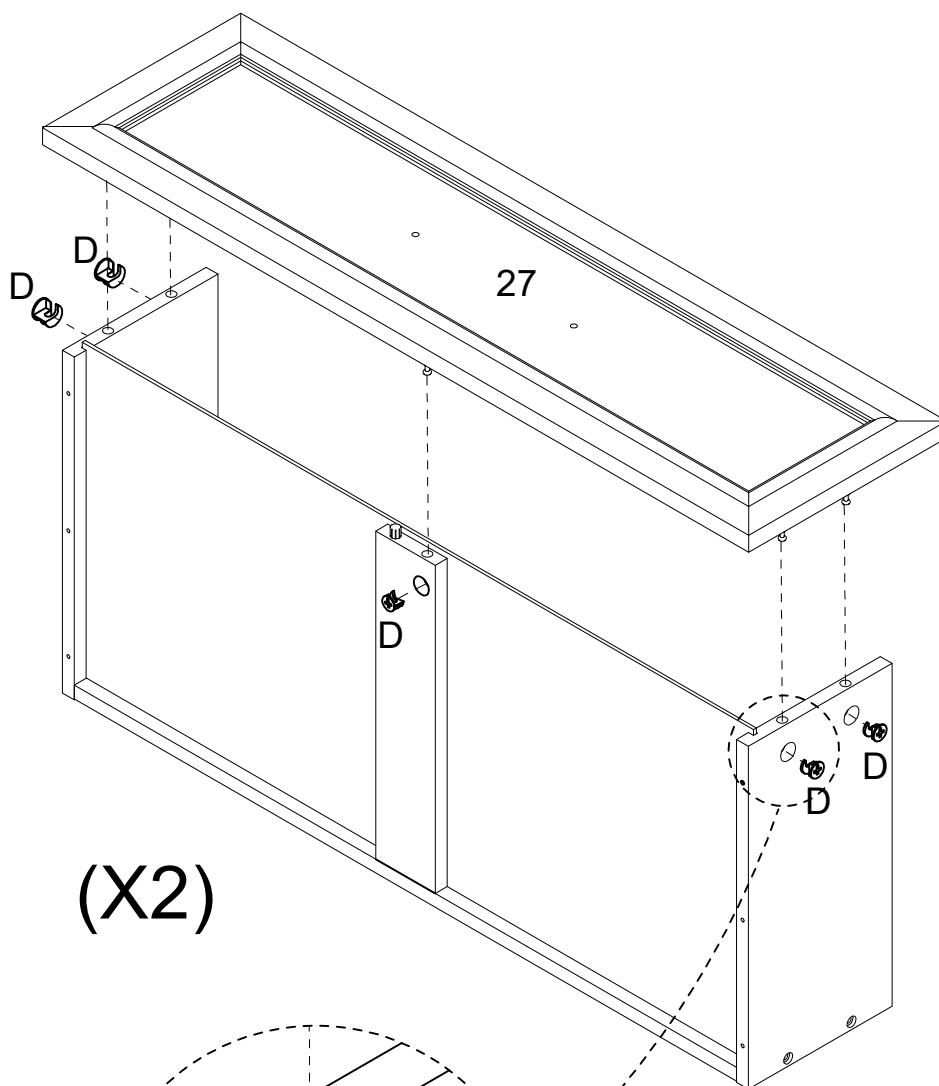
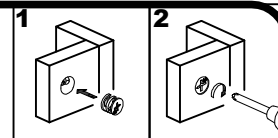
# Step 30



D

X10

# Step 31

NOTE:

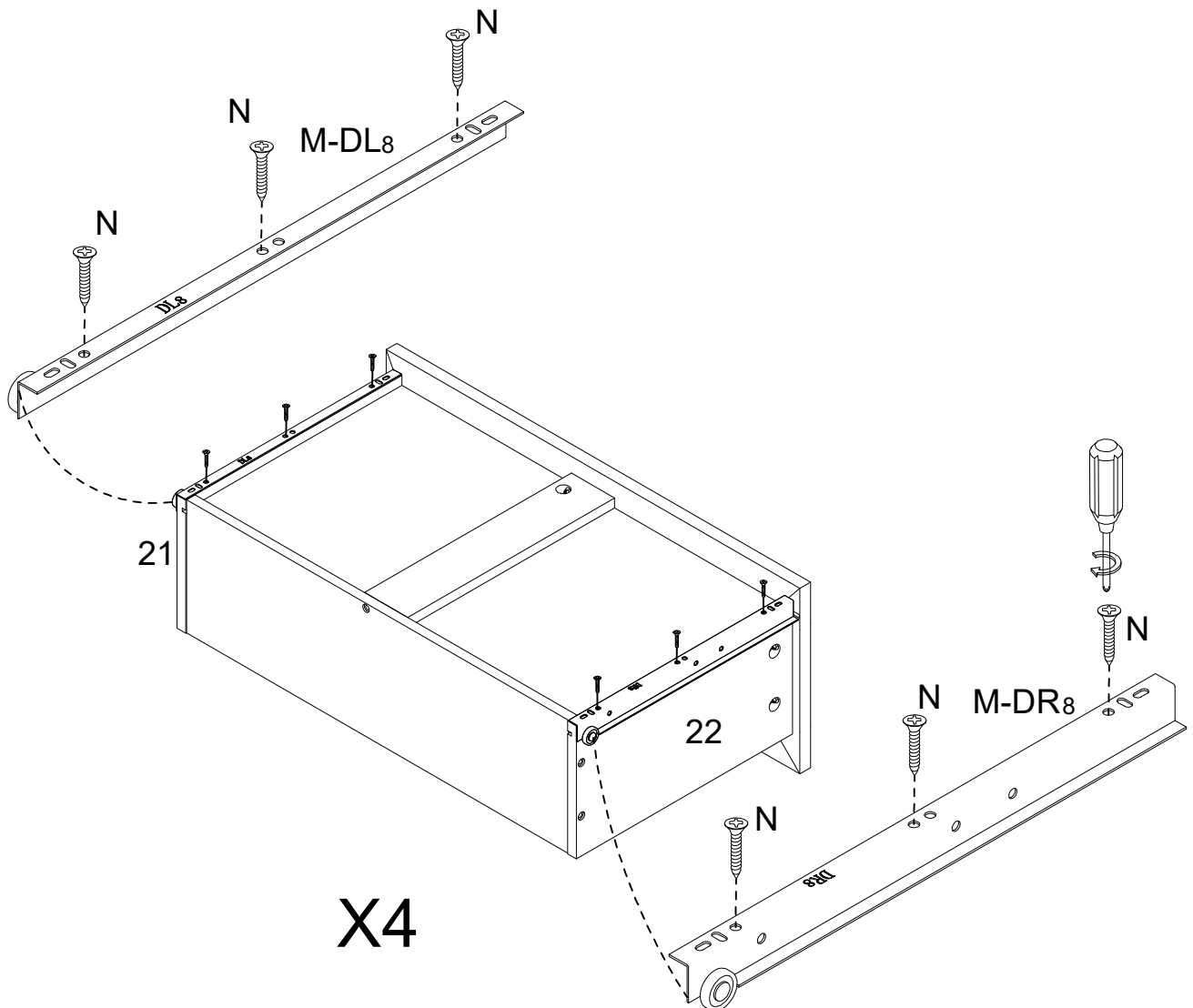

Refer to the images to identify M-DL8 (left) and M-DR8 (right). Attach M-DL8 to #21 panel and M-DR8 to #22 panel. [R] screws must go in the exact spots shown.

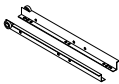

X4

N	M
	
X24	X4

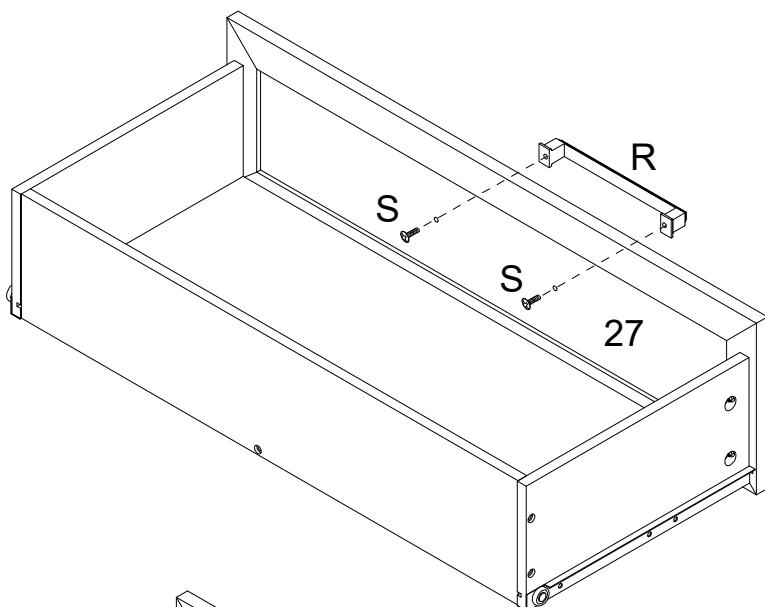

# Step 32

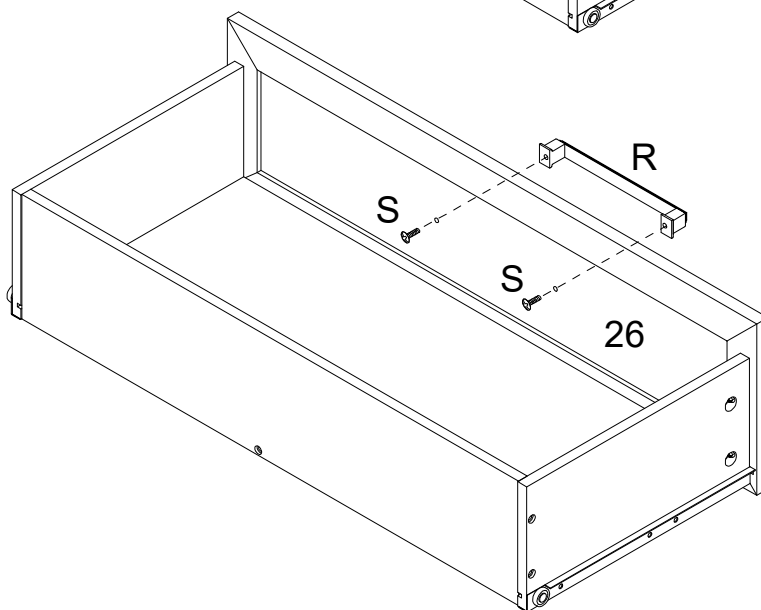

X2



X2

S	R
	
X8	X4

# Step 33

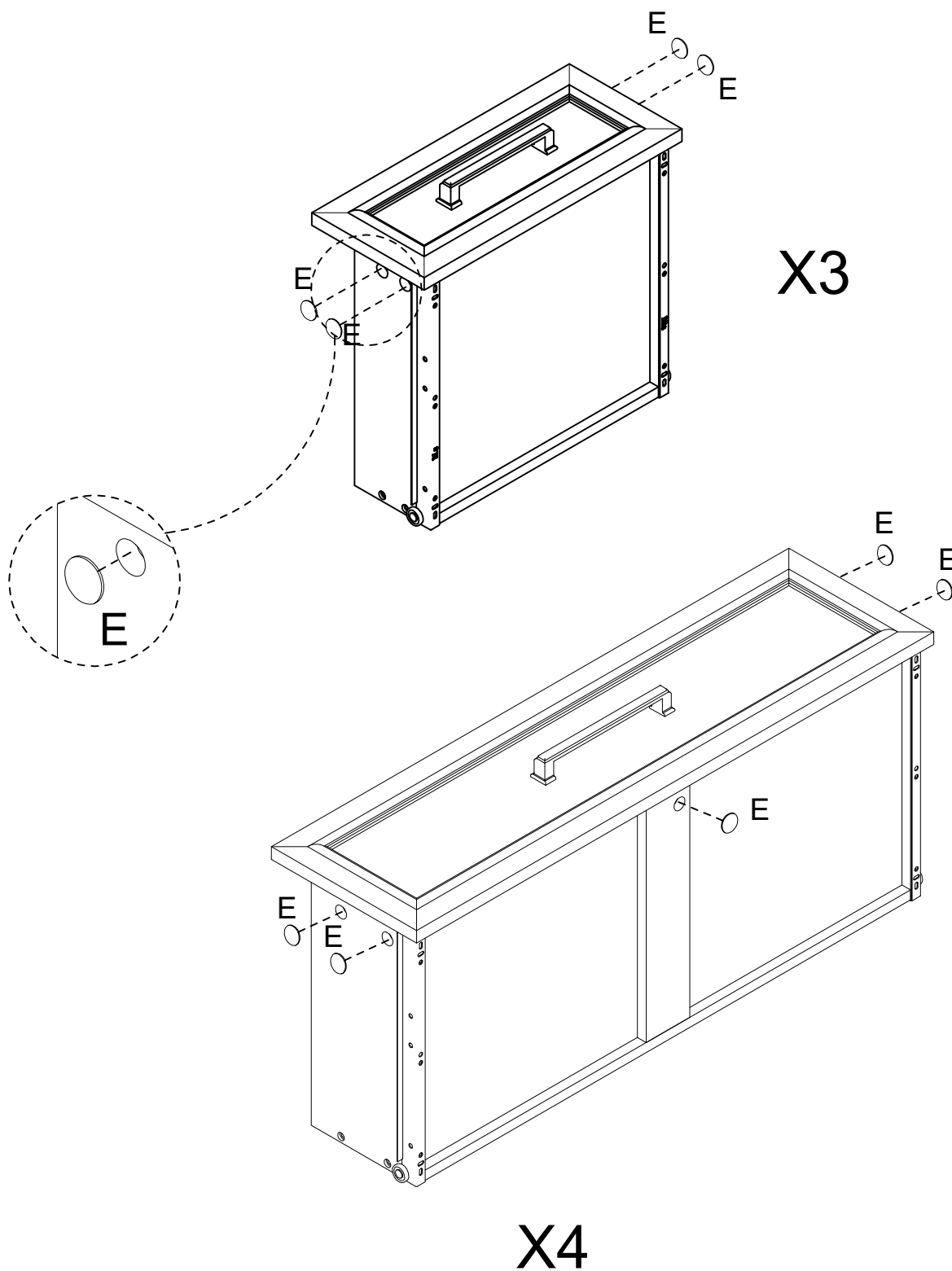

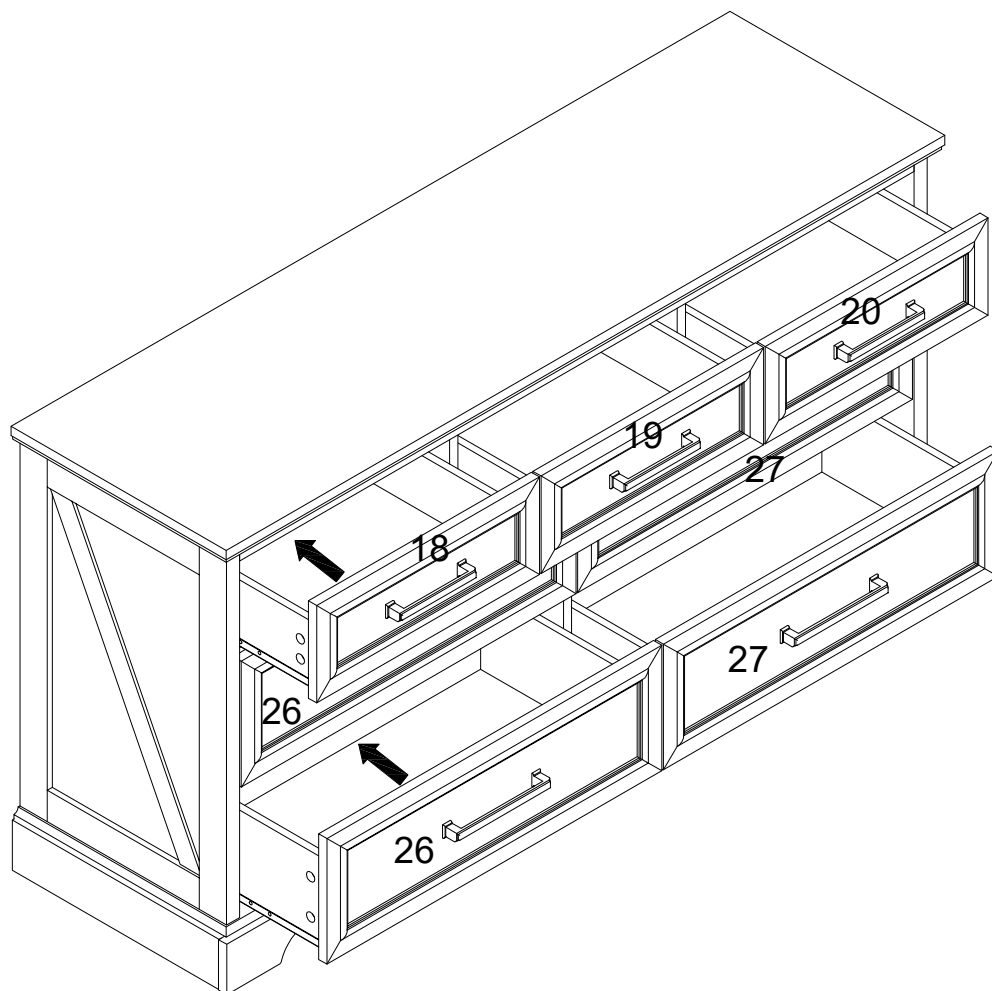

E
○
X32

# Step 34

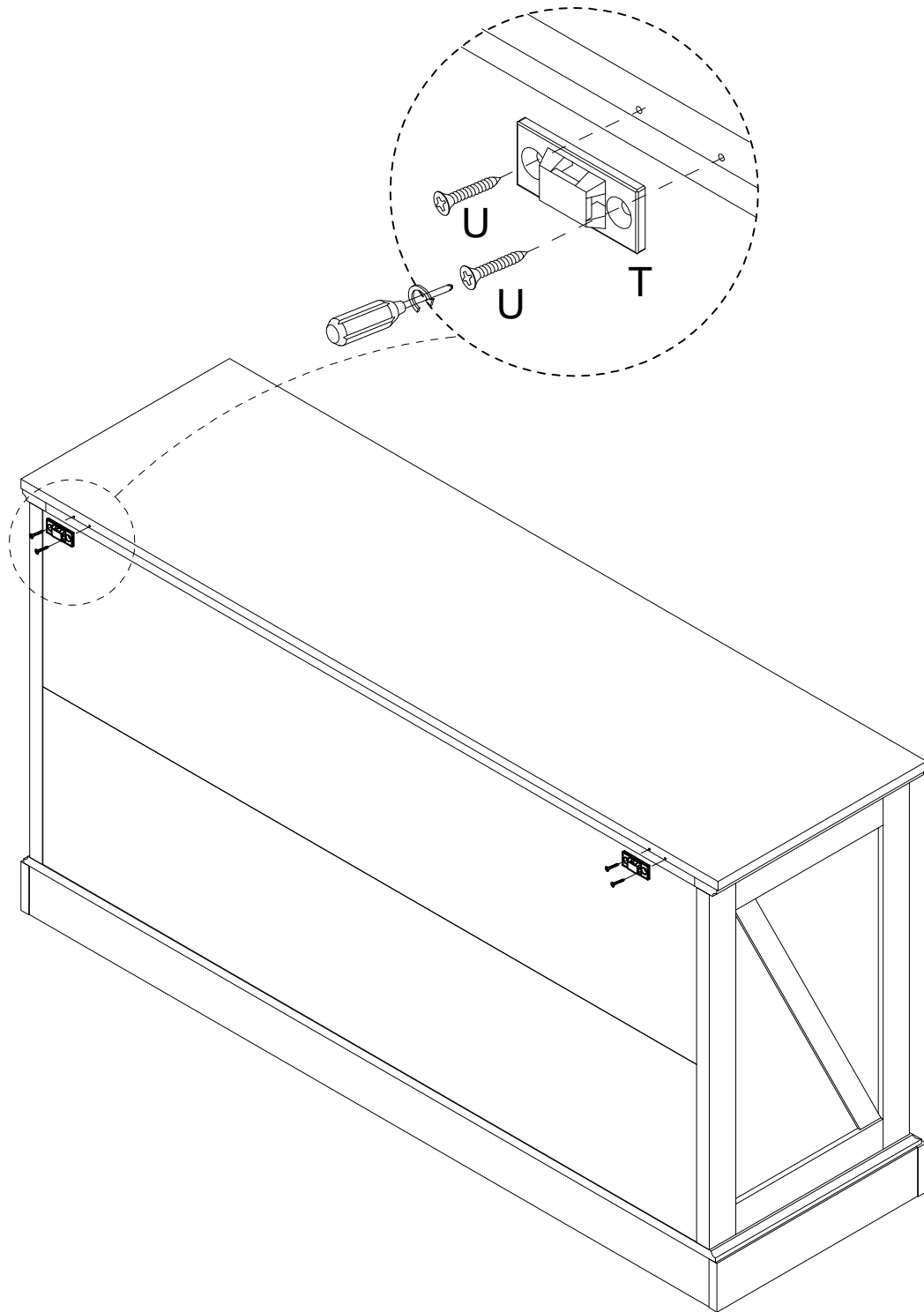

# Step 35



T	U
	
X2	X4

# Step 36

Make Four holes 45MM deep

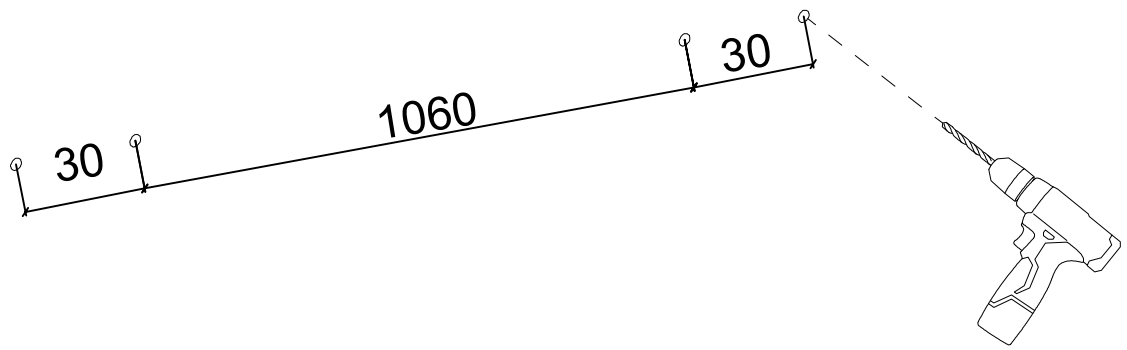

Wall

# Step 37

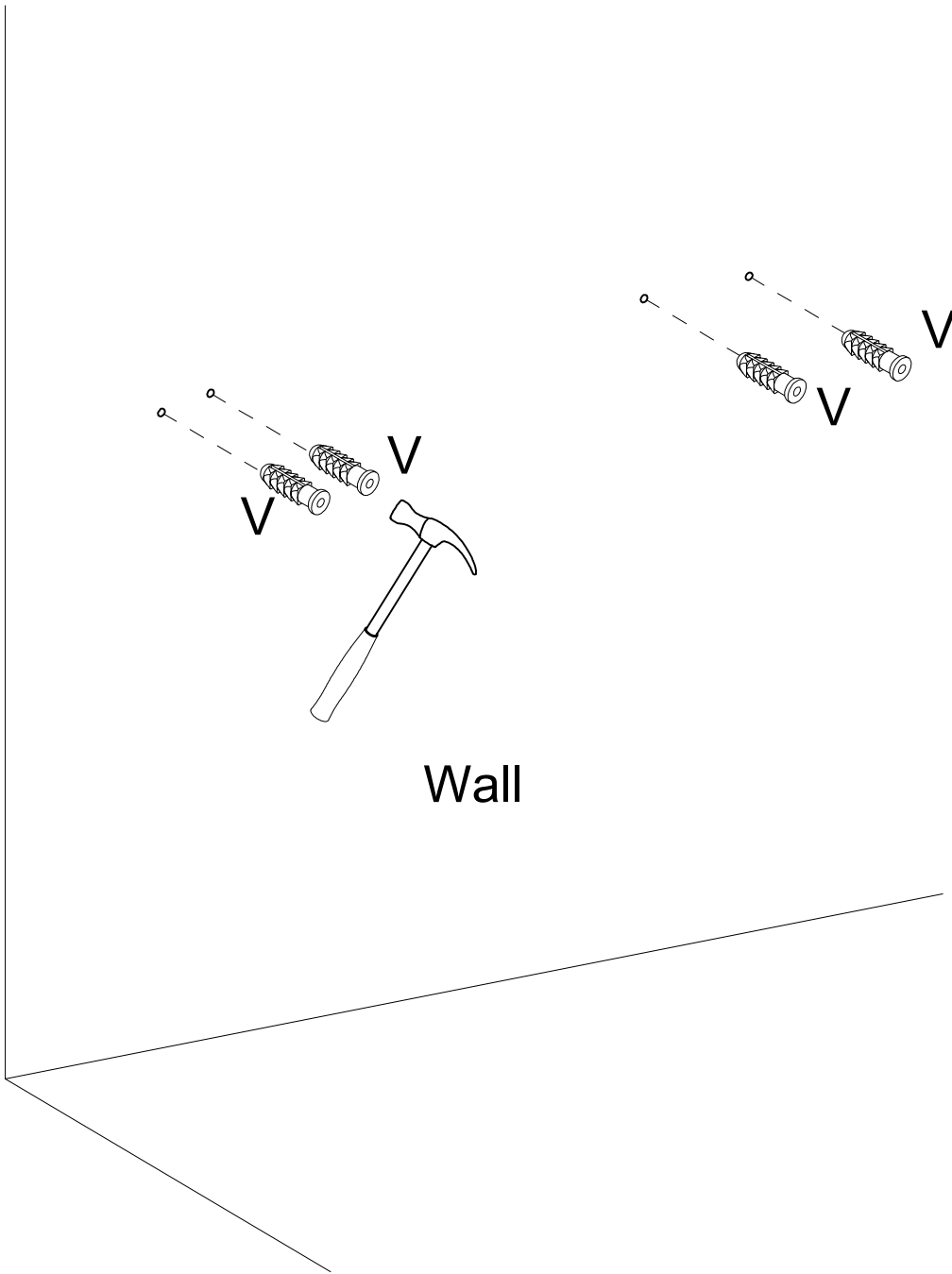

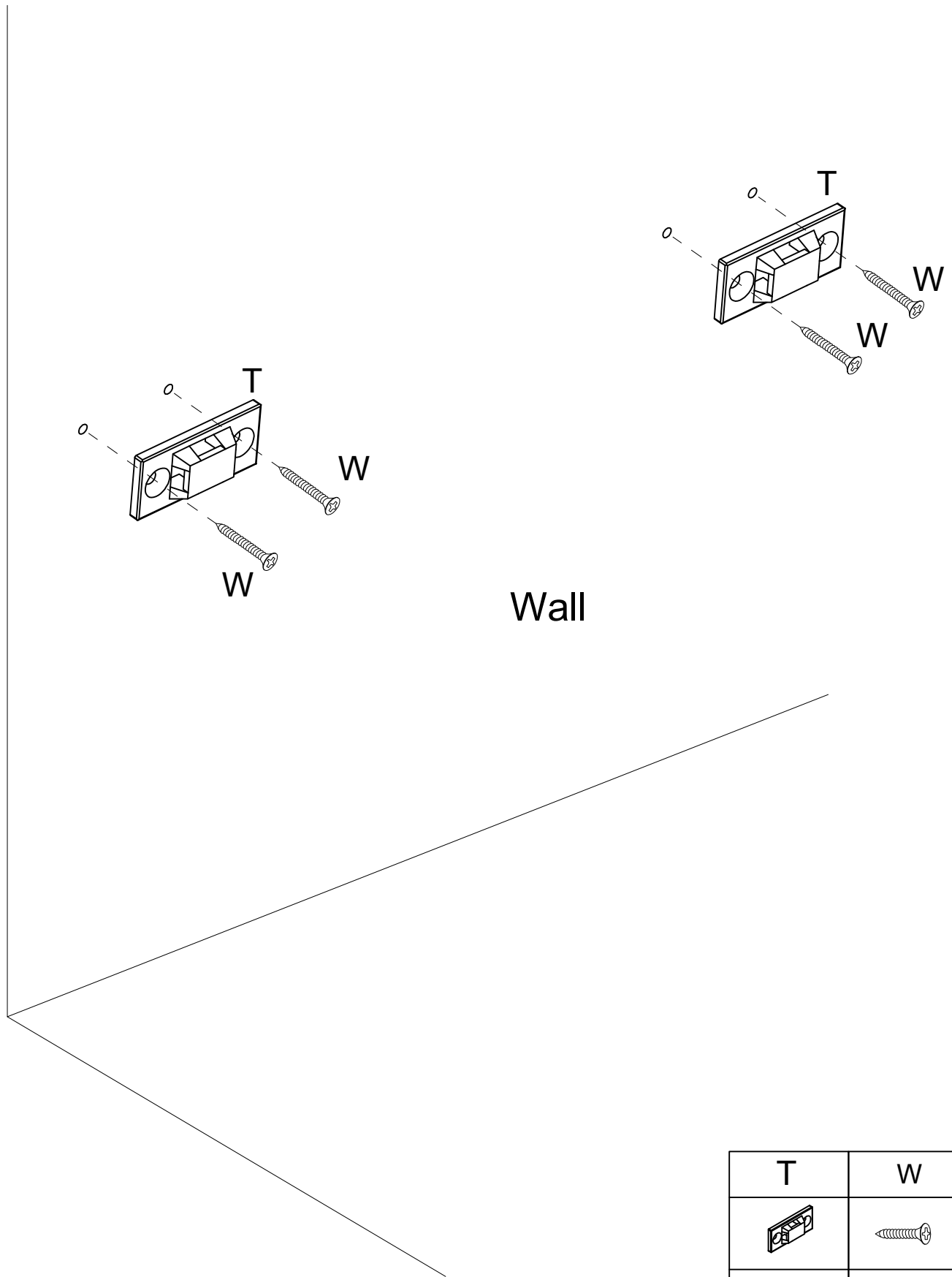

V

X4

# Step 38



Wall

T	W
	
X2	X4

# Step 39

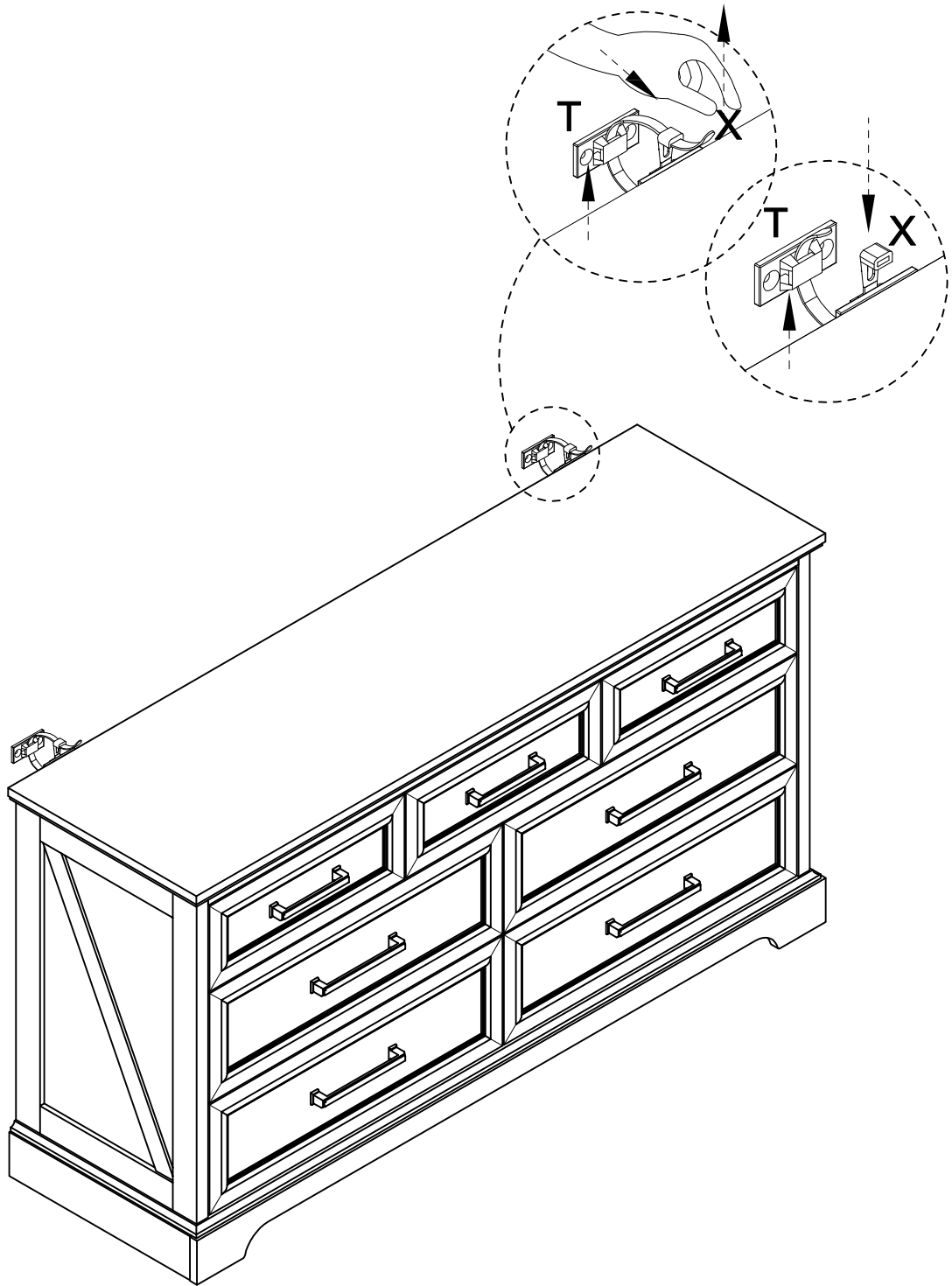

X

X2

# Step 40

