

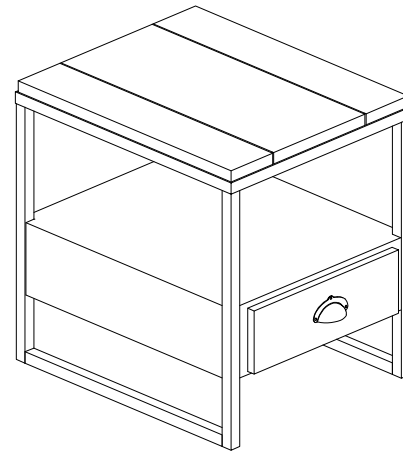





ASSEMBLY INSTRUCTIONS

990-915 RECTANGULAR DRAWER END TABLE







No.	Hardware List	Q'ty
1	 M5/16"	1pc
2	 Ø5/16 "x5/8 "	4pcs
3	 Ø5/16"	8pcs
4	 Ø5/16"*19mm	8pcs
5	 Ø5/16 "x1/2 "	8pcs
6	 Ø5/16 "x1-1/4 "	4pcs
7	 Ø5/32 "x5/8 "	2pcs

1st Step:

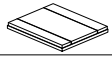
Firstly ,lay top(A) face-down on a clear and smooth surface.

Then attach Left leg(B) to top(A) with allen head bolt(5). Use allen wrench(1) to tighten the bolts. Don't fully tighten . As in shown, Right leg (C) is the same as Left Leg(B).

No.	Part List	Q'ty
A		1pc
B		2pcs
C		2pcs
D		1pc
E		2pcs

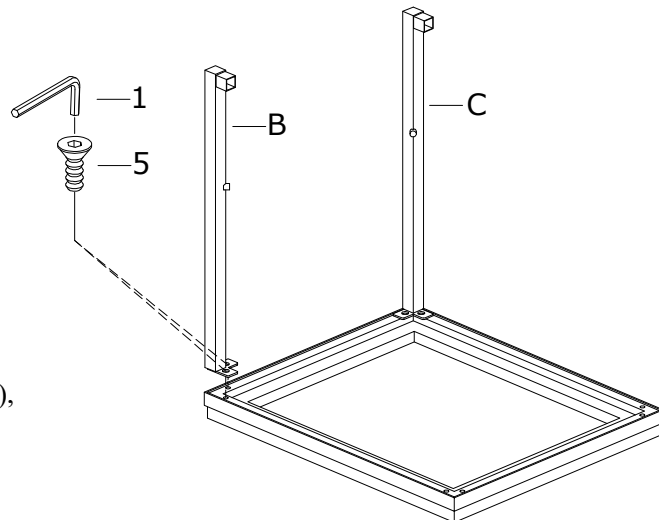

2nd Step:

Insert stretcher(E) into hole in legs(B,C) WITH FLAT WASHER(4), spring washer(3), allen head bolt(2), Use allen wrench(1) to tighten the bolts.Don't fully tighten.As in shown.

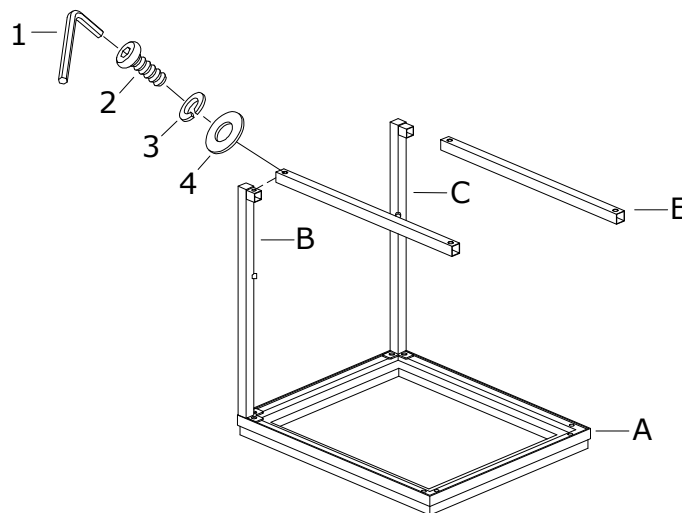

3rd Step:

Get out the drawer from cabinet(D) and put it face front, keep cabinet(D) to legs(B,C) with flat washer(3), allen head bolt(6), use allen wrench(1) to tighten the bolts. Don't fully tighten. As in shown.

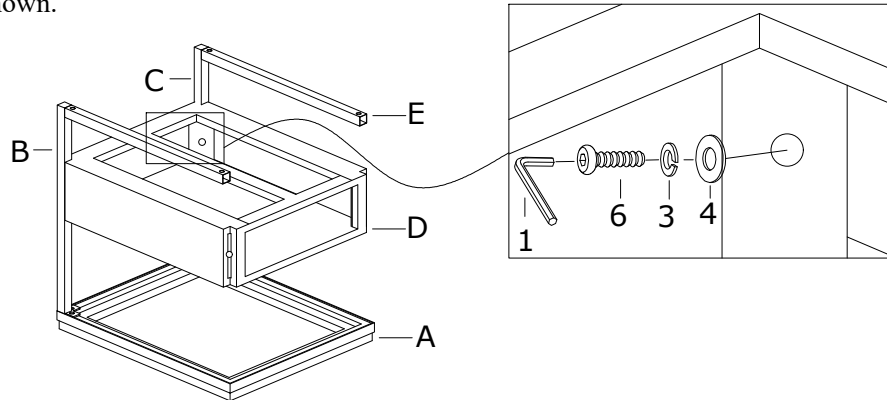

4th Step:

Attach another leg(B) to top(A), cabinet(D), stretcher(E) with allen head bolt(5), flat washer(4),spring washer(3), allen head bolt(6,2), finally, use allen wrench(1) to tighten all the bolts, Leg(C) is the same as Leg(B),As in shown.

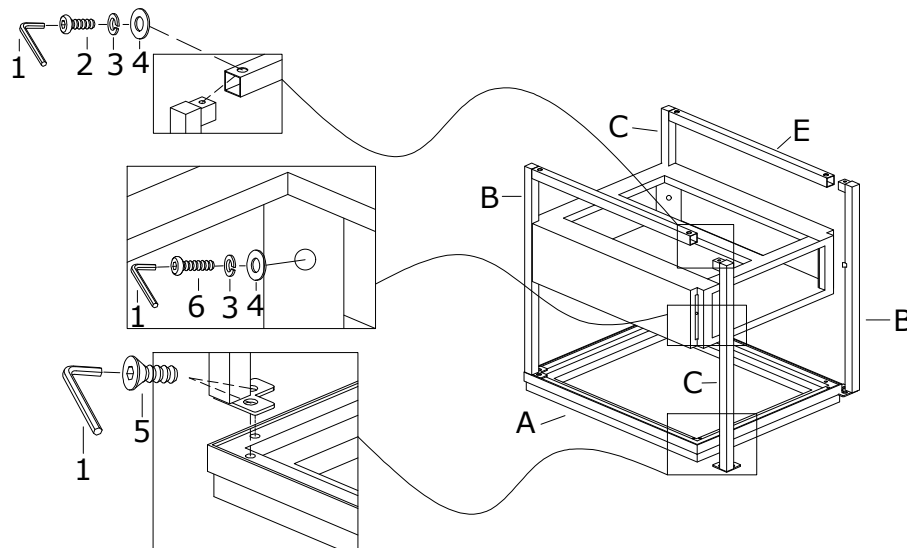

5th Step:

Turn assembly table upright position. Get down the drawer knob in drawer. Then screw it onto drawer with flat head bolt(7). Finally, place the drawer into cabinet(D), As in shown.

