

"IMPORTANT, RETAIN FOR FUTURE REFERENCE: READ CAREFULLY"

German: WICHTIG, FÜR SPÄTERE NACHSCHLAGE AUFBEWAHREN: SORGFÄLTIG LESEN

Spanish: IMPORTANTE, GUARDAR PARA REFERENCIA FUTURA: LEER ATENTAMENTE

Italian: IMPORTANTE, CONSERVARE PER RIFERIMENTI FUTURI: LEGGERE ATTENTAMENTE

French: IMPORTANT, À CONSERVER POUR RÉFÉRENCE FUTURE : LIRE ATTENTIVEMENT



1. Two or more people are required for assembly.

2. To avoid squeaking, please tighten the bolts all the way.

An electric drill is recommended for the assembly.

3. Professional installation is highly recommended.

1. Für den Zusammenbau werden zwei oder mehr Personen benötigt.

2. Um Quietschgeräusche zu vermeiden, ziehen Sie die Schrauben bitte ganz fest.

Die Verwendung einer elektrischen Bohrmaschine wird empfohlen.

3. Ein fachgerechter Einbau wird dringend empfohlen.

1. Il faut au moins deux personnes pour le montage.

2. Pour éviter tout grincement, veuillez serrer les boulons à fond. Il est recommandé d'utiliser une perceuse électrique.

3. Une installation professionnelle est fortement recommandée.

1. E' necessario due o più persone per l'installazione.

2. Per evitare cigolii, serrare bene i bulloni. Si consiglia di utilizzare un trapano elettrico.



3. Si consiglia vivamente un'installazione professionale.

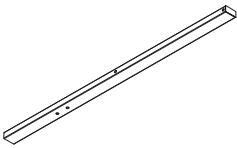
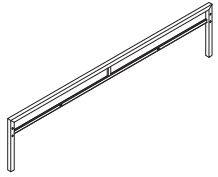
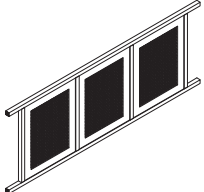
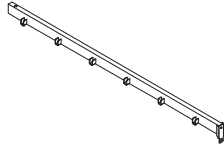
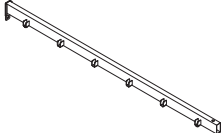
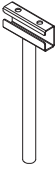

1. Se necesitan dos o más personas para el montaje.

2. Para evitar chirridos, apriete todos los tornillos. Se recomienda utilizar un taladro eléctrico.

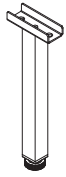
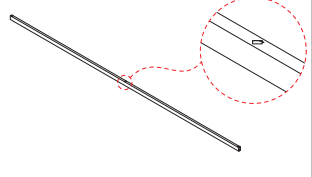
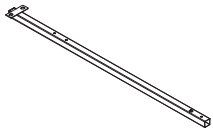
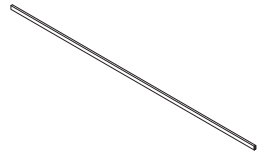
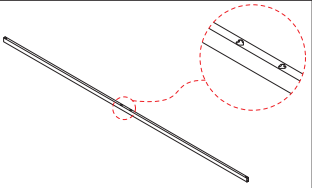
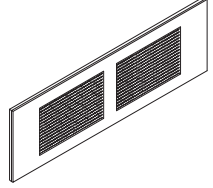
3. Se recomienda encarecidamente la instalación profesional.

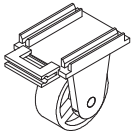
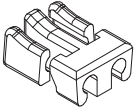
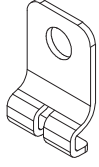
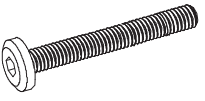
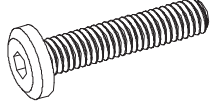
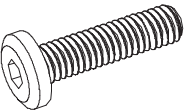
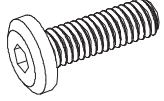
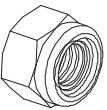
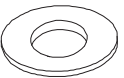
Item no. Nr. N° d'article Articolo No. Artículo No.	Reference Image Referenzbild Image de référence Immagine di riferimento Imagen de referencia	Qty. Menge Qté. Qtà Cant.	Item no. Nr. N° d'article Articolo No. Artículo No.	Reference Image Referenzbild Image de référence Immagine di riferimento Imagen de referencia	Qty. Menge Qté. Qtà Cant.
1		X2	2		X1
3		X1	4		X2
5		X2	6		X2

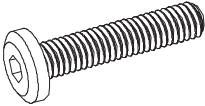

Item no. Nr. N° d'article Articolo No. Artículo No.	Reference Image Referenzbild Image de référence Immagine di riferimento Imagen de referencia	Qty. Menge Qté. Qtà Cant.	Item no. Nr. N° d'article Articolo No. Artículo No.	Reference Image Referenzbild Image de référence Immagine di riferimento Imagen de referencia	Qty. Menge Qté. Qtà Cant.
7		X3	8		X2
9		X2	10		X8
11		X2	12		X2
13		X2	14		X8
15		X4	16		X2
A	 M6X70mm	X4	B	 M8X40mm	X8
C	 M6X35mm	X12	D	 M5X25mm	X8
E	 M8	X8	F	 φ8	X8

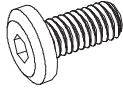
Item no. Nr. N° d'article Articolo No. Artículo No.	Reference Image Referenzbild Image de référence Immagine di riferimento Imagen de referencia	Qty. Menge Qté. Qtà Cant.
<b>G</b>		<b>X1</b>
<b>I</b>	 M8X55mm	<b>X4</b>
<b>K</b>	 φ6	<b>X4</b>

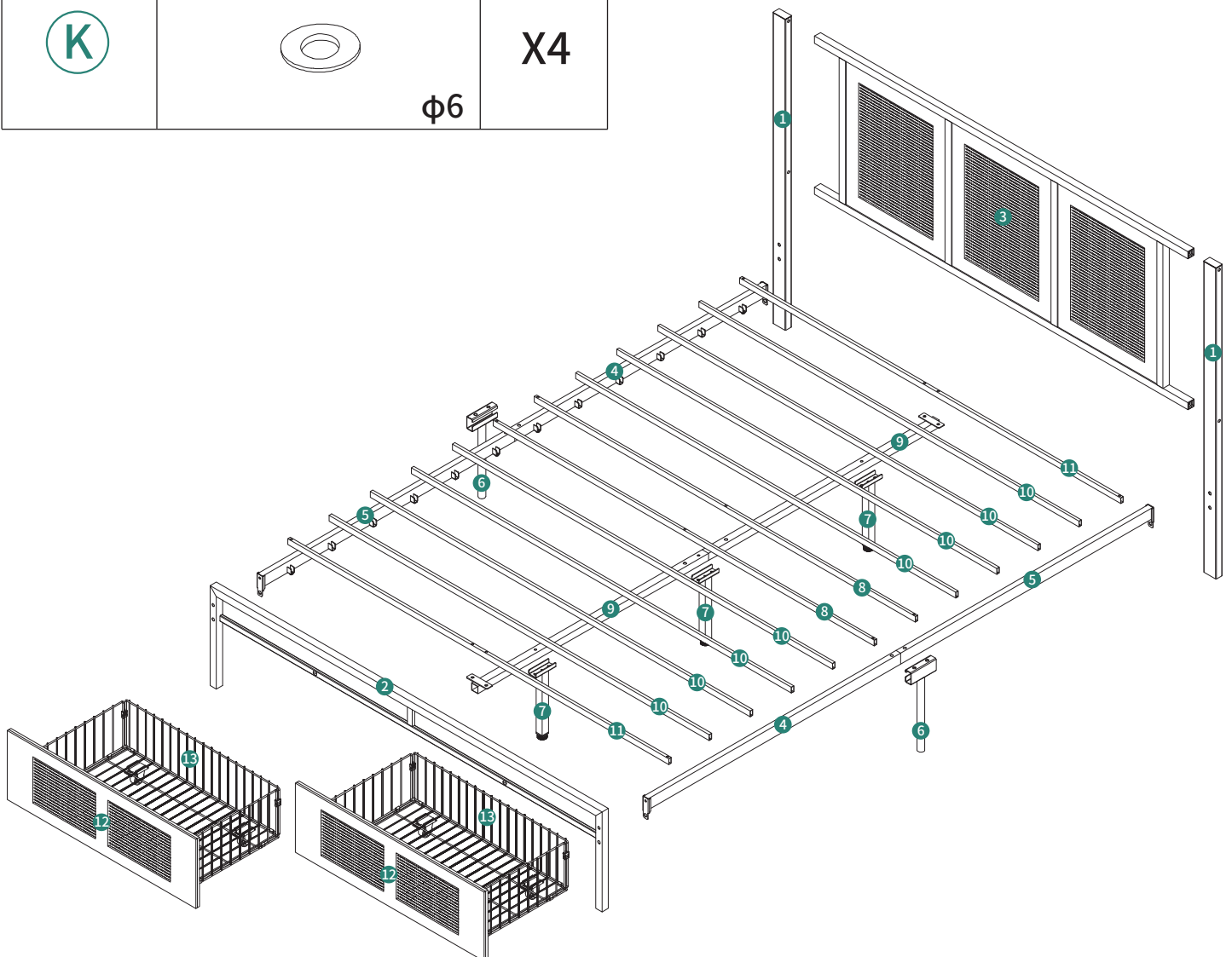
Item no. Nr. N° d'article Articolo No. Artículo No.	Reference Image Referenzbild Image de référence Immagine di riferimento Imagen de referencia	Qty. Menge Qté. Qtà Cant.
<b>H</b>		<b>X1</b>
<b>J</b>	 M6X12mm	<b>X12</b>

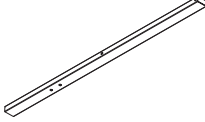
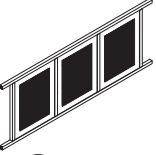

**1**

			
① 2pcs	③ 1pc	M6X70mm Ⓐ 4pcs	φ6 Ⓚ 4pcs

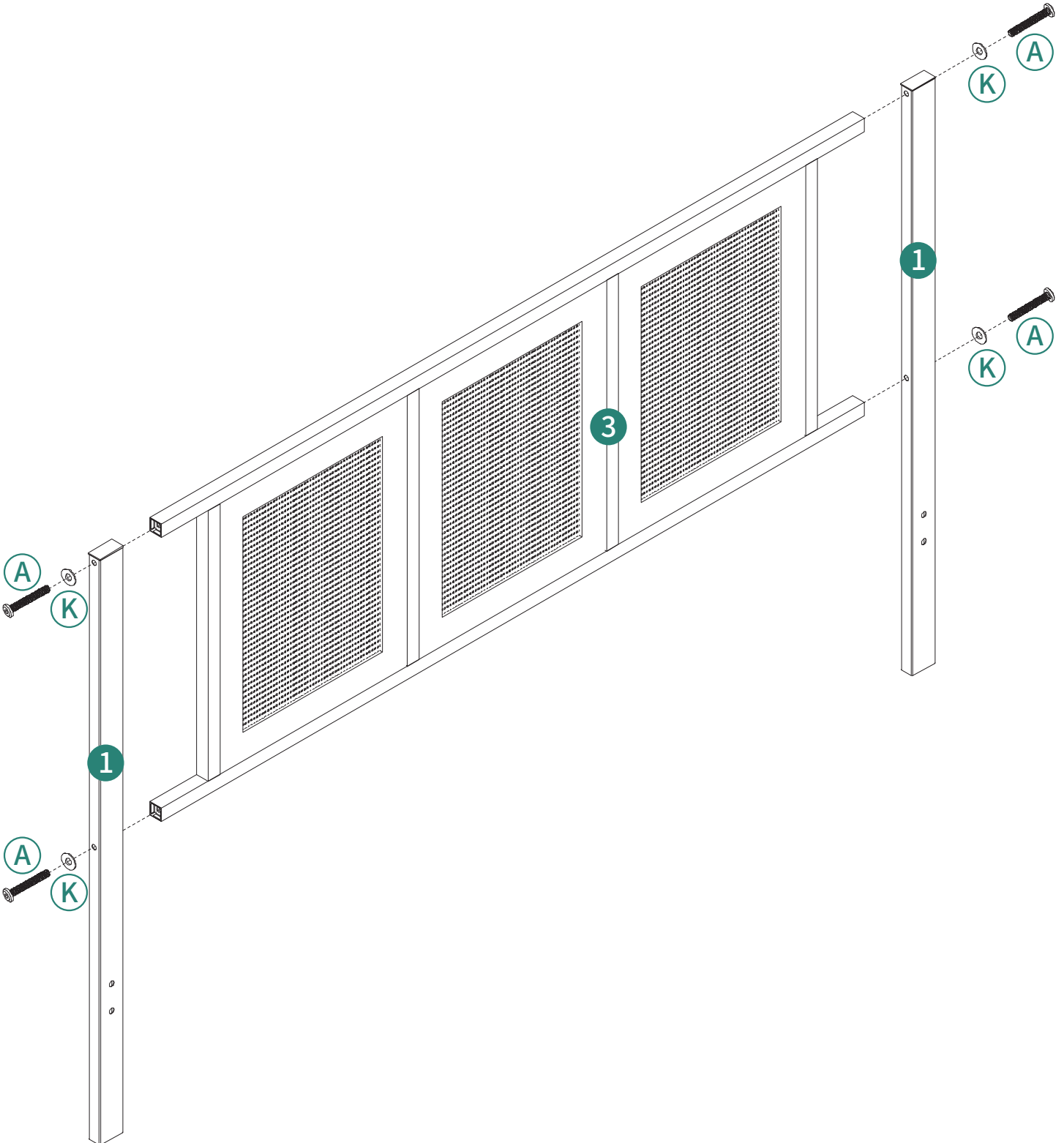

2

X2

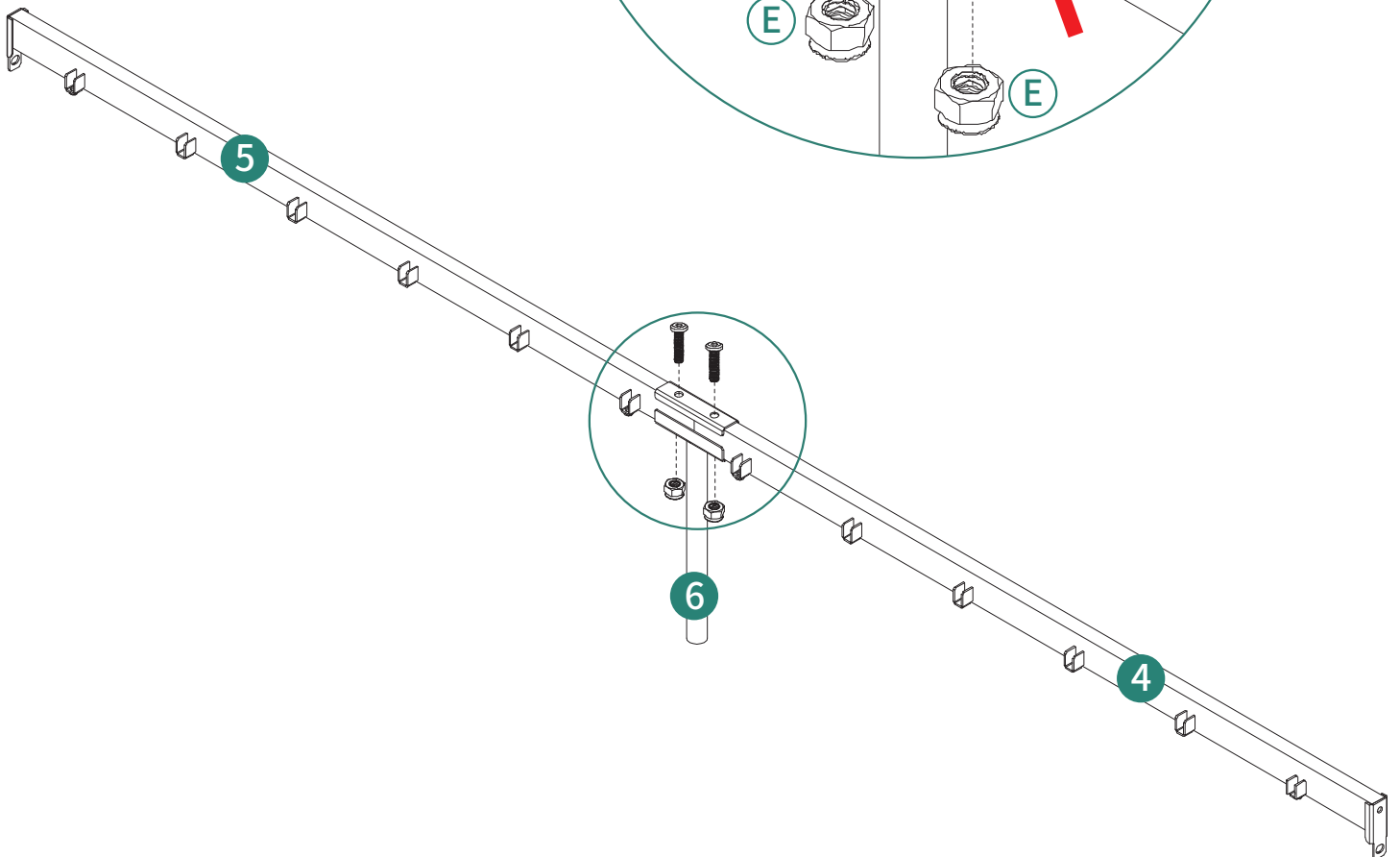
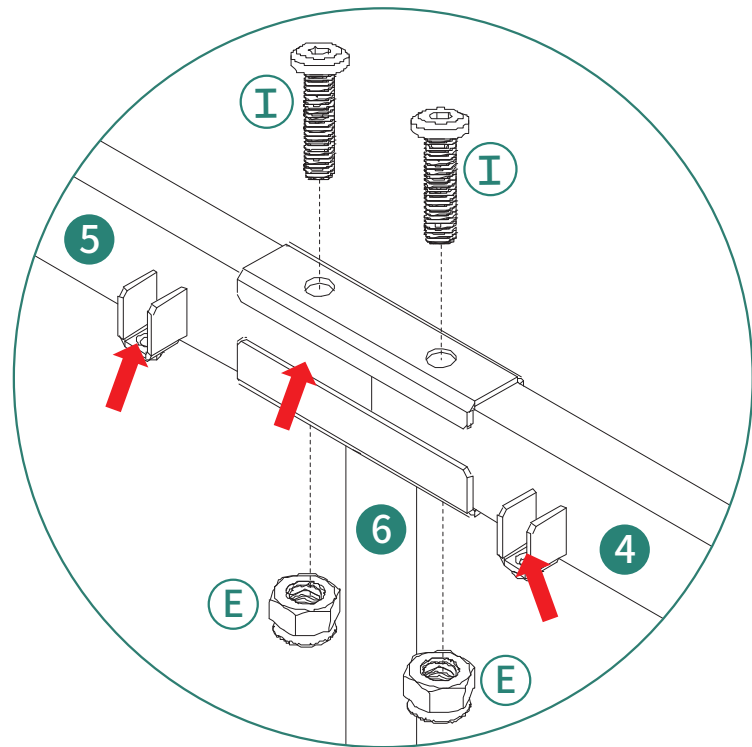
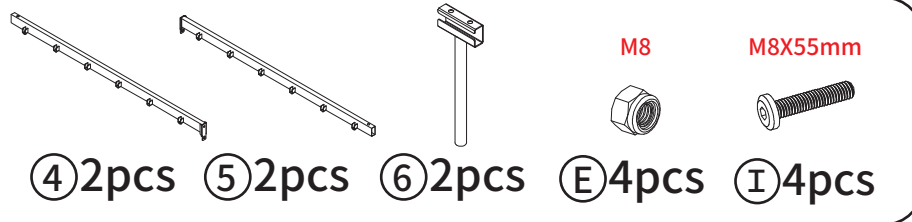

# 3

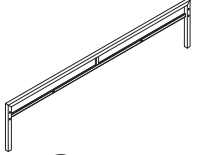
	M8X40mm	M8	φ8
②1pc	Ⓑ8pcs	Ⓔ4pcs	Ⓕ8pcs

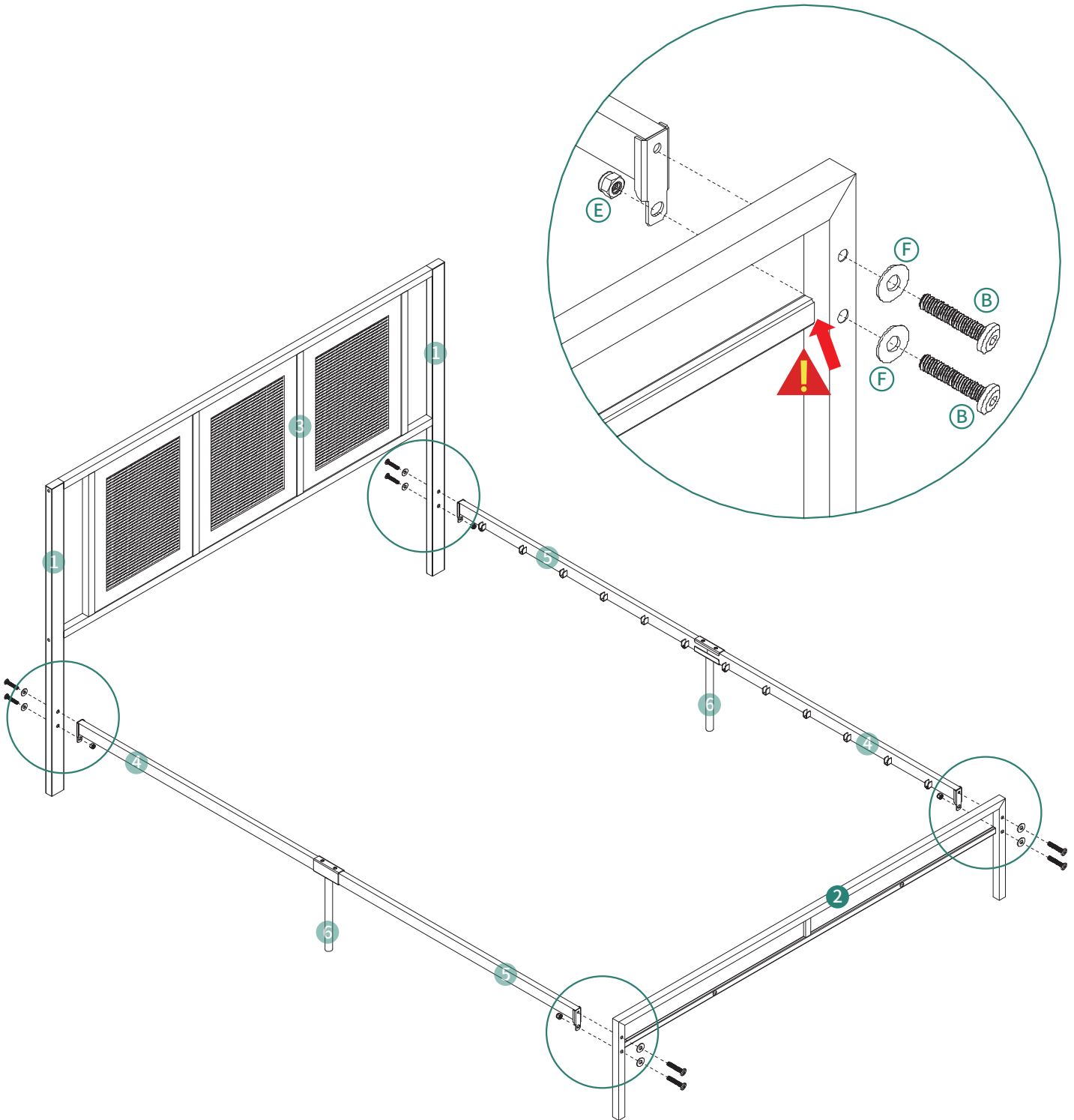

4

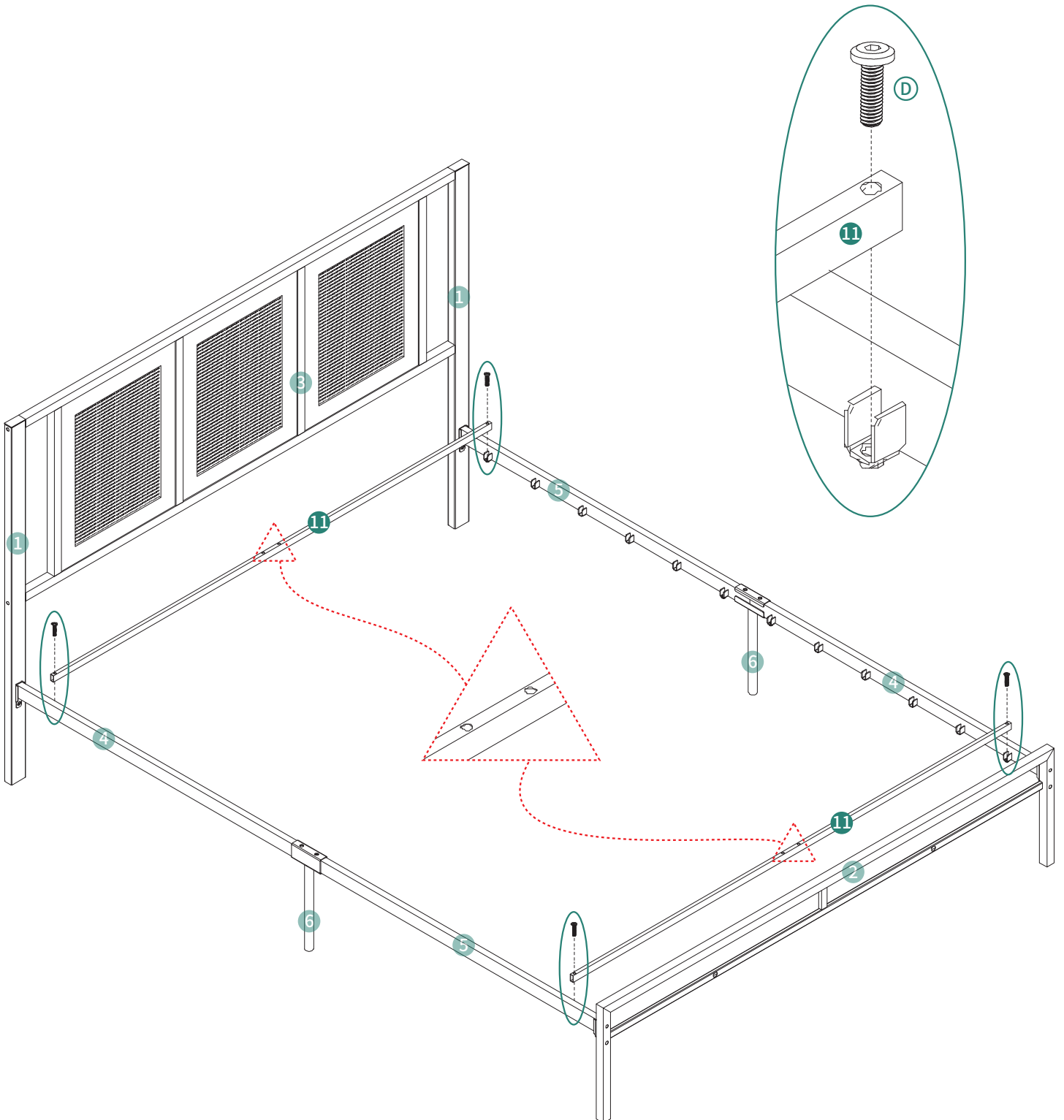
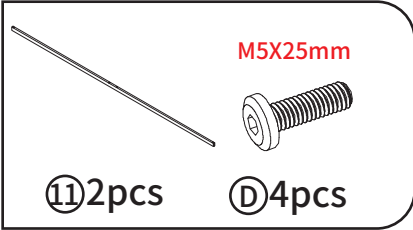

# 5

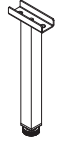
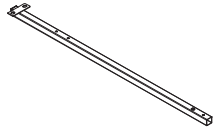
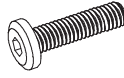
-  ⑦ 3pcs
-  ⑨ 2pcs
-  M6X35mm  
① C 6pcs

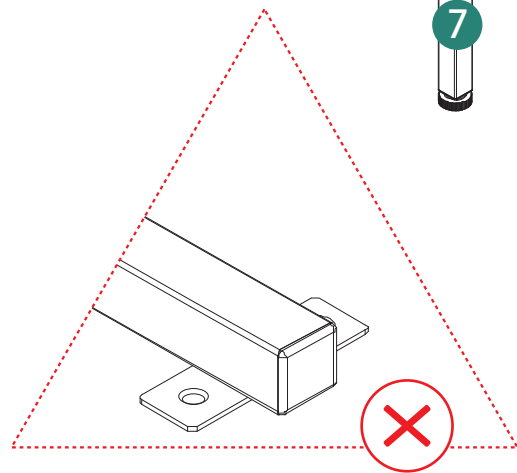
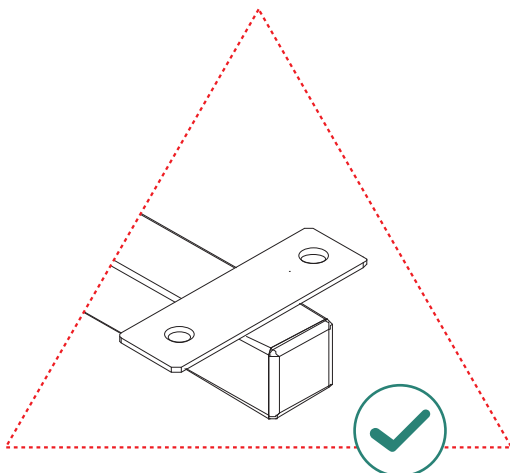
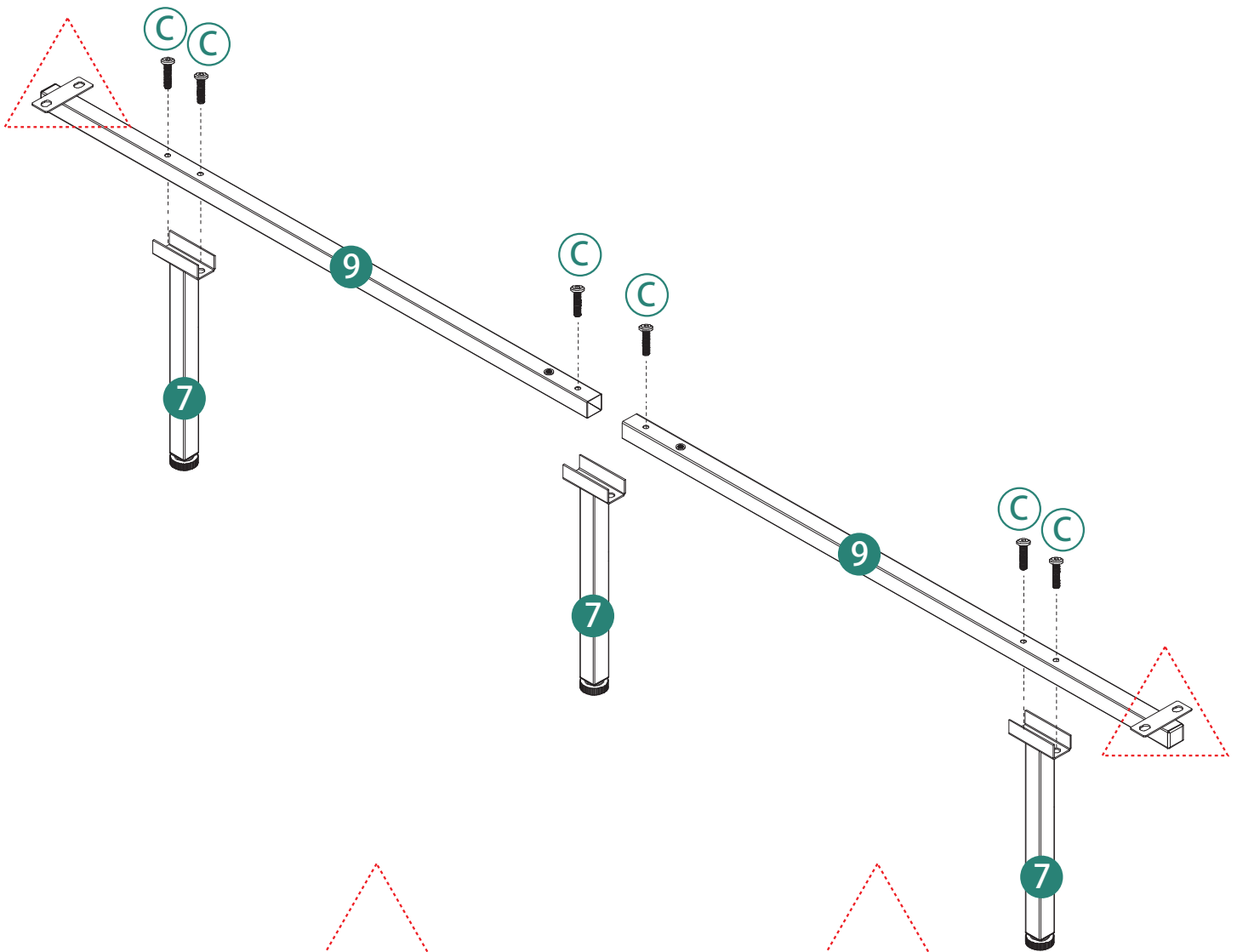

**6**

M6X35mm



Ⓒ4pcs

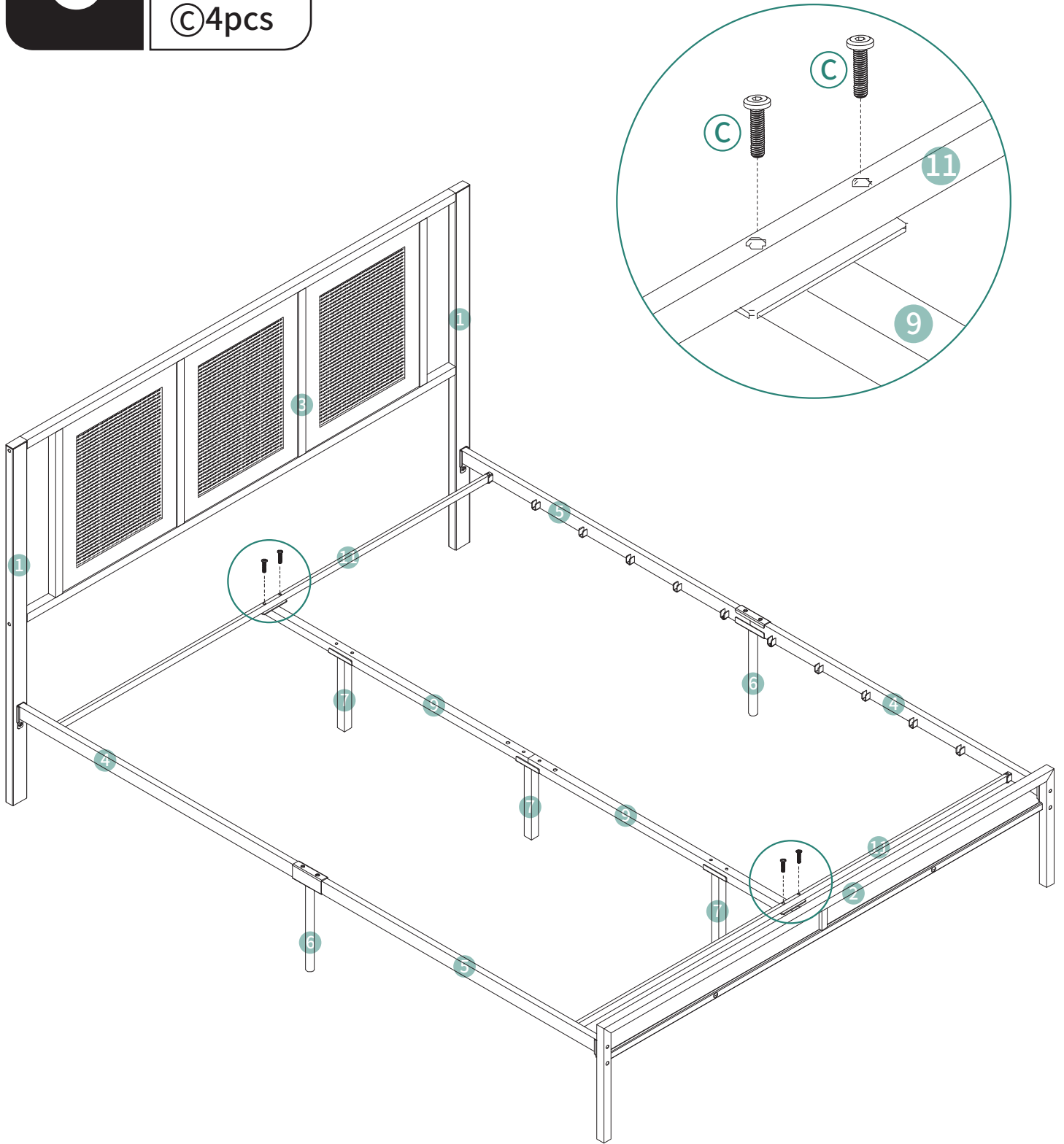

7

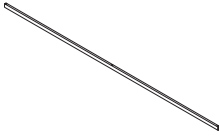

⑧ 2pcs

M6X35mm

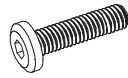

③ 2pcs

M5X25mm

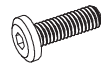

④ 4pcs

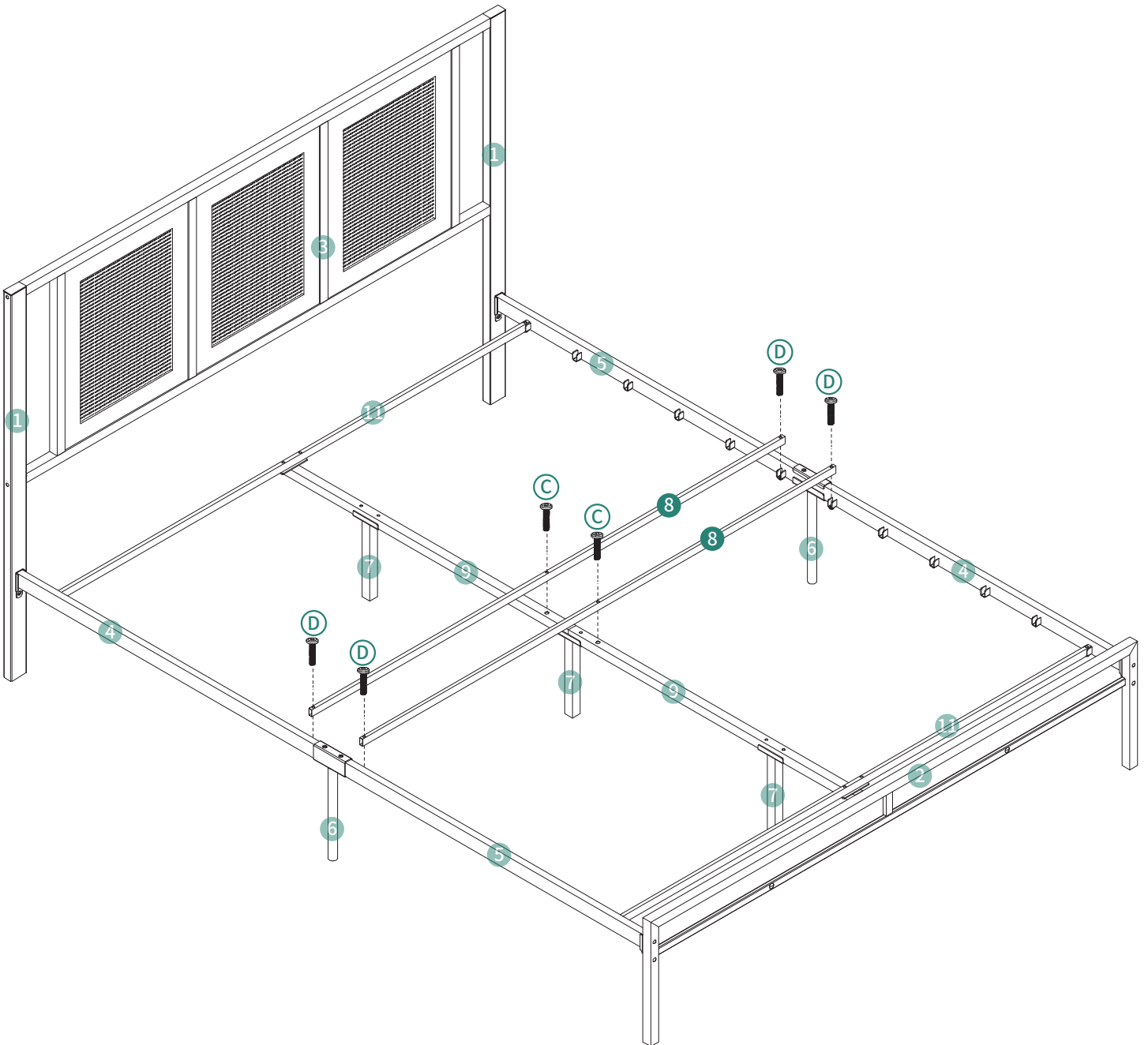

**8**



⑩ 8pcs

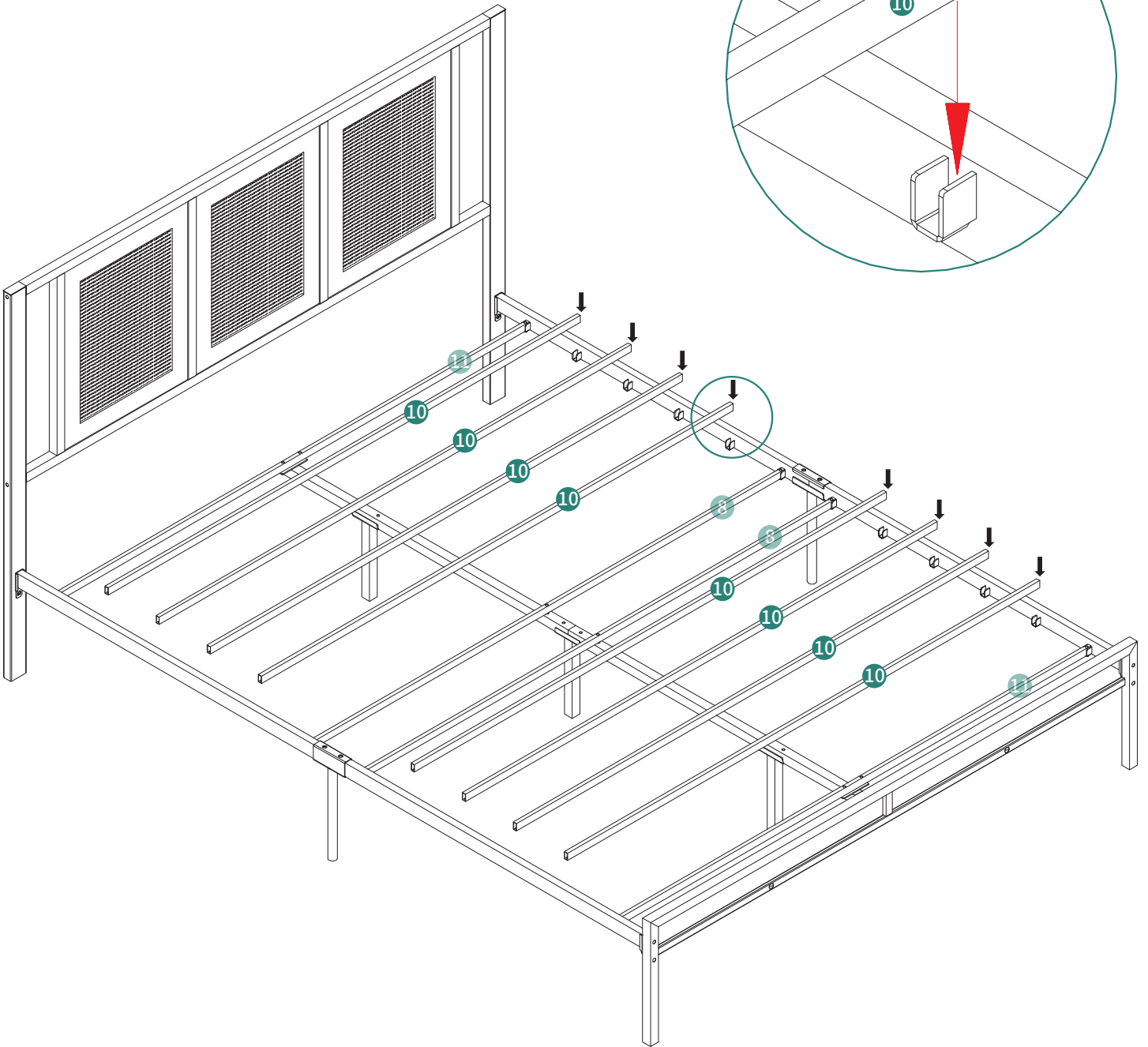

9

X2



⑬ 2pcs

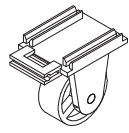

⑭ 8pcs

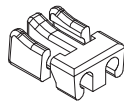

⑮ 4pcs

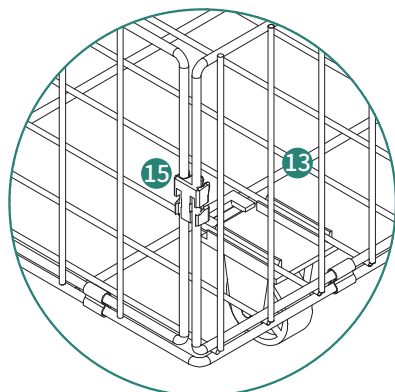
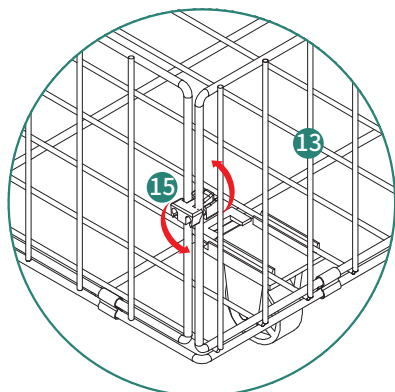
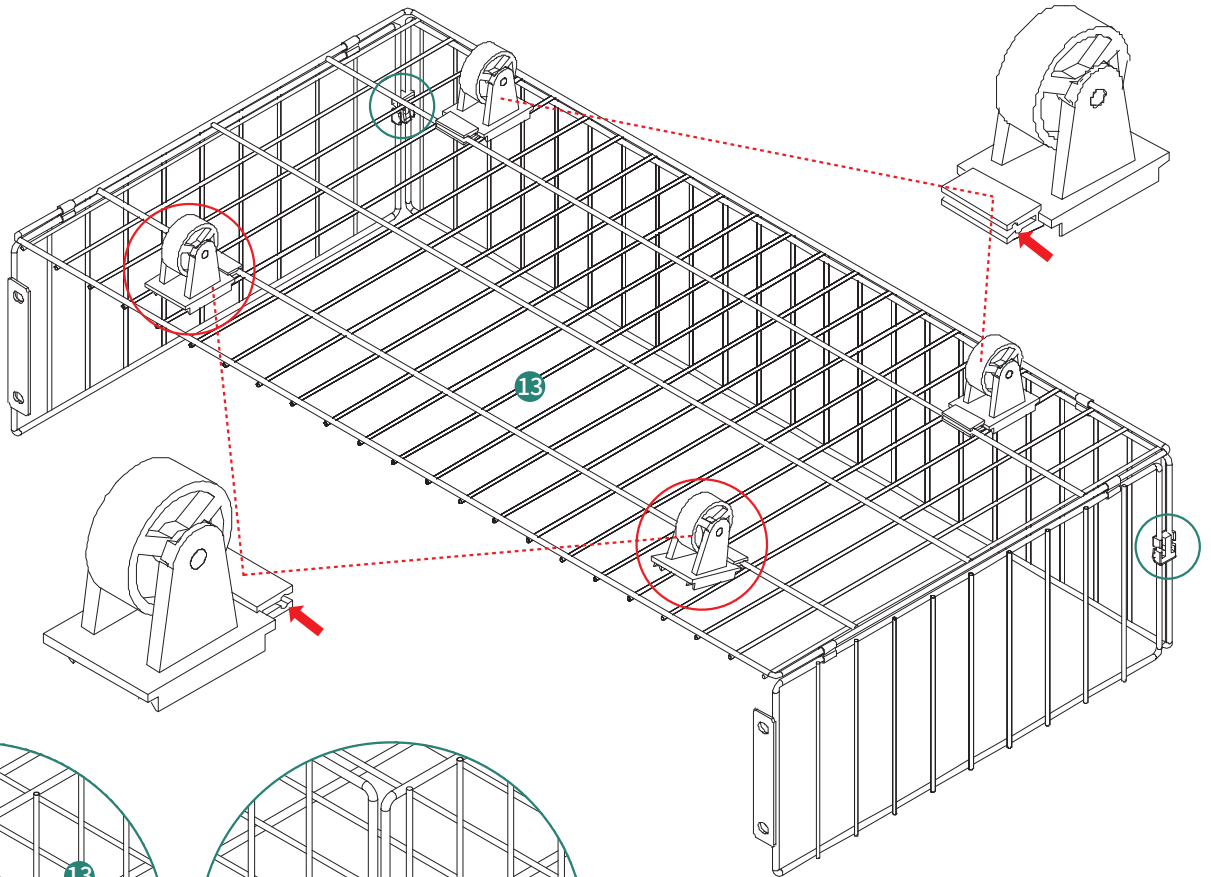
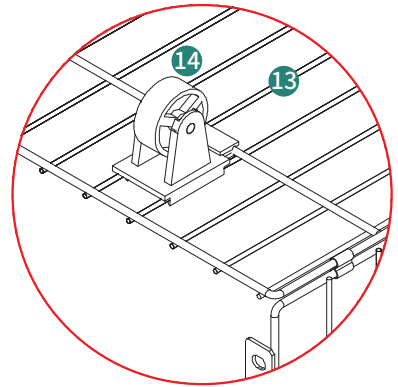
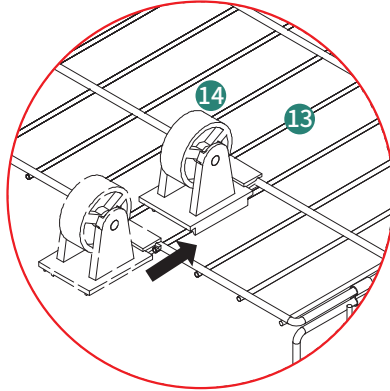
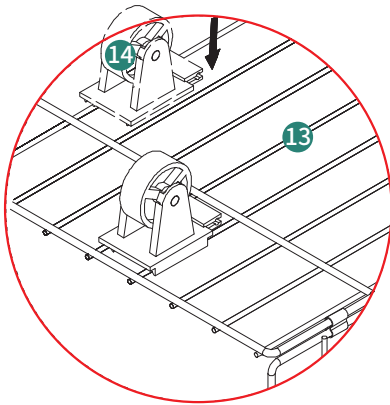

**10**  
**X2**

⑫2pcs   ⑮2pcs   ①12pcs

M6X12mm

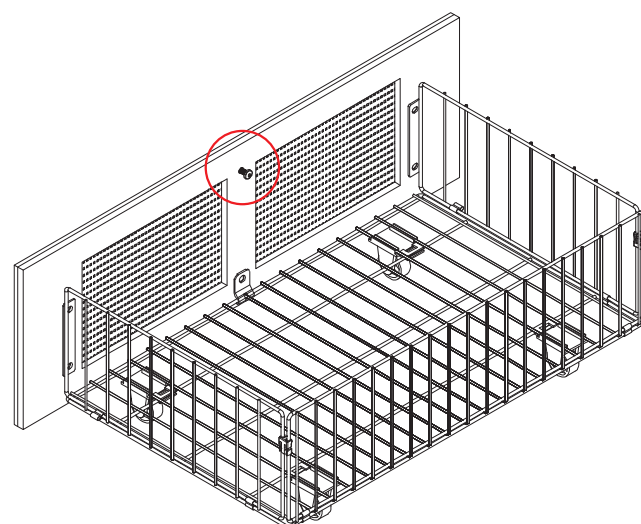
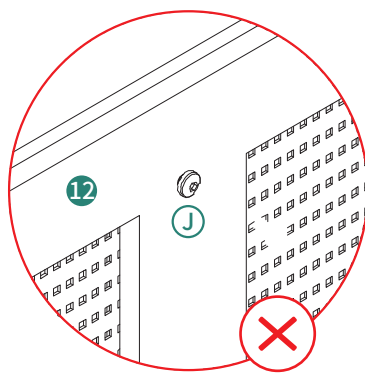
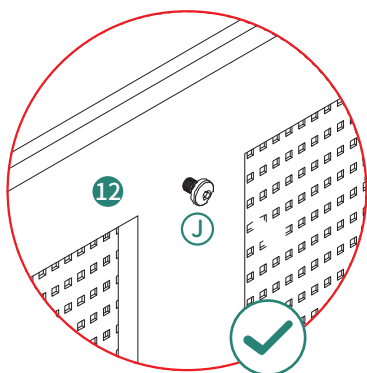
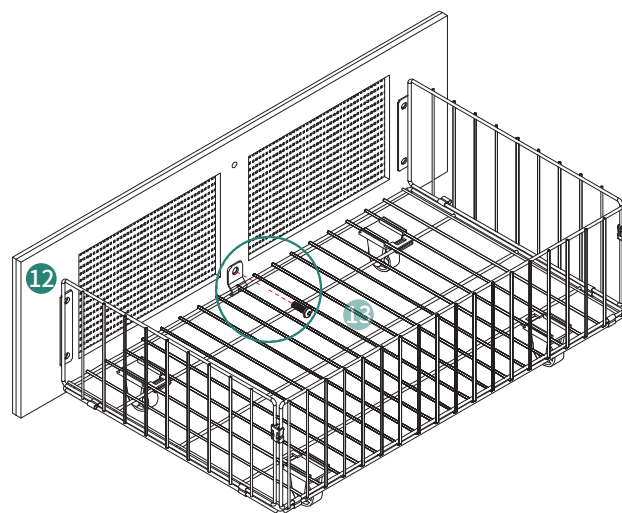
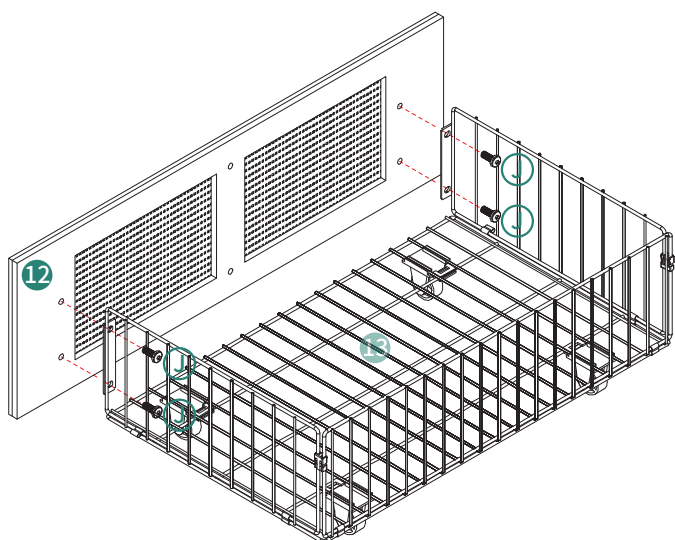
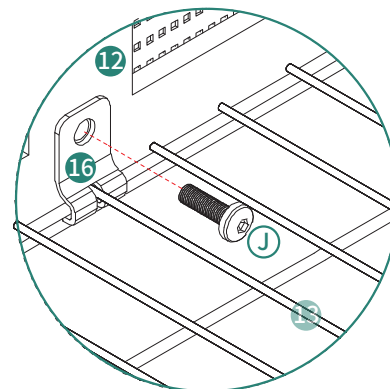

Note: Do not fully tighten the screws (leave a gap of approximately 5mm).  
 Bitte die Schrauben nicht vollständig festziehen (lassen Sie einen Abstand von etwa 5 mm).  
 Ne serrez pas complètement les vis (laissez un espace d'environ 5 mm).  
 Non serrare completamente le viti (lasciare uno spazio di circa 5 mm).  
 No apriete completamente los tornillos (deje un espacio de aproximadamente 5 mm).

11

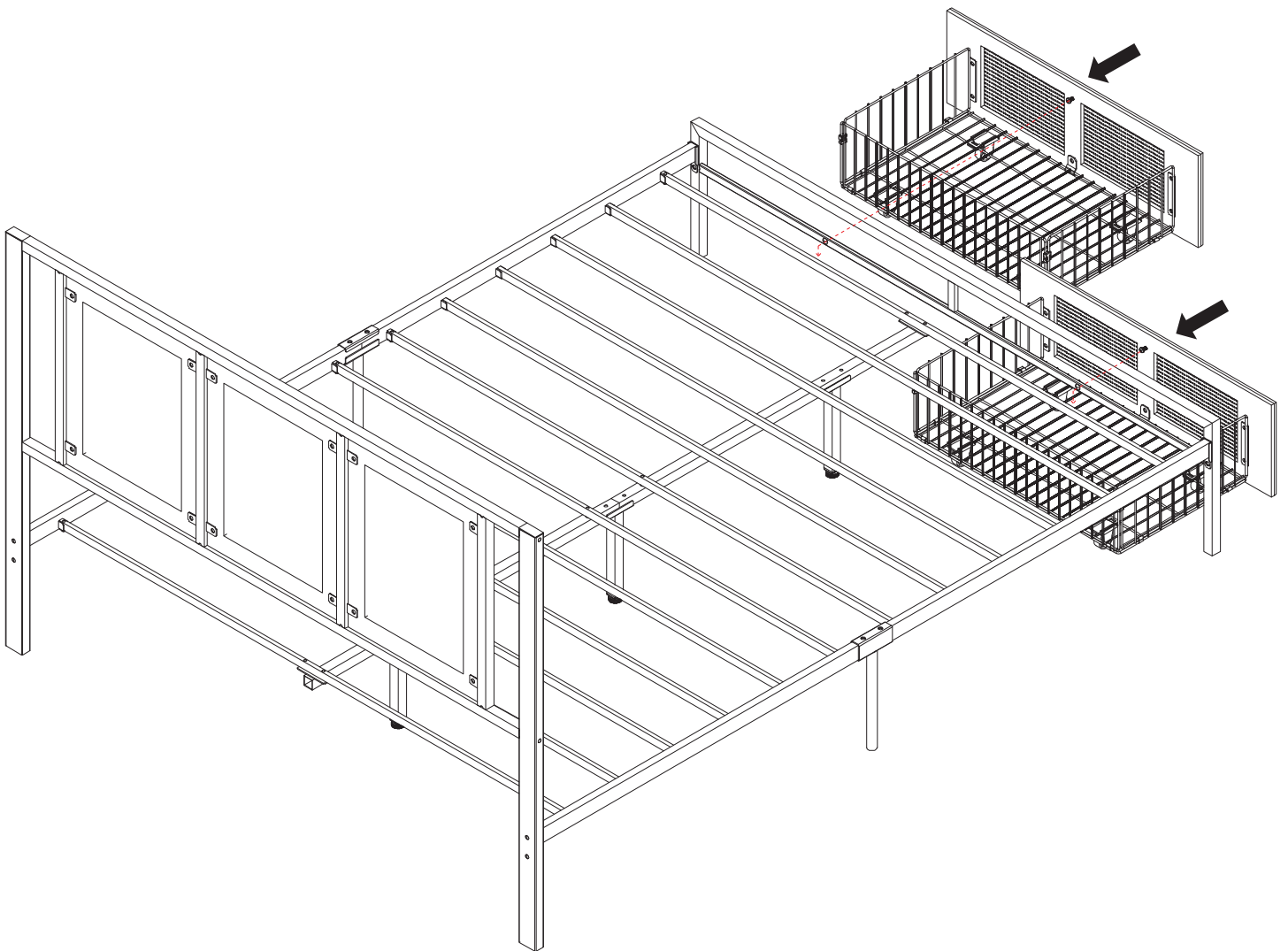

12

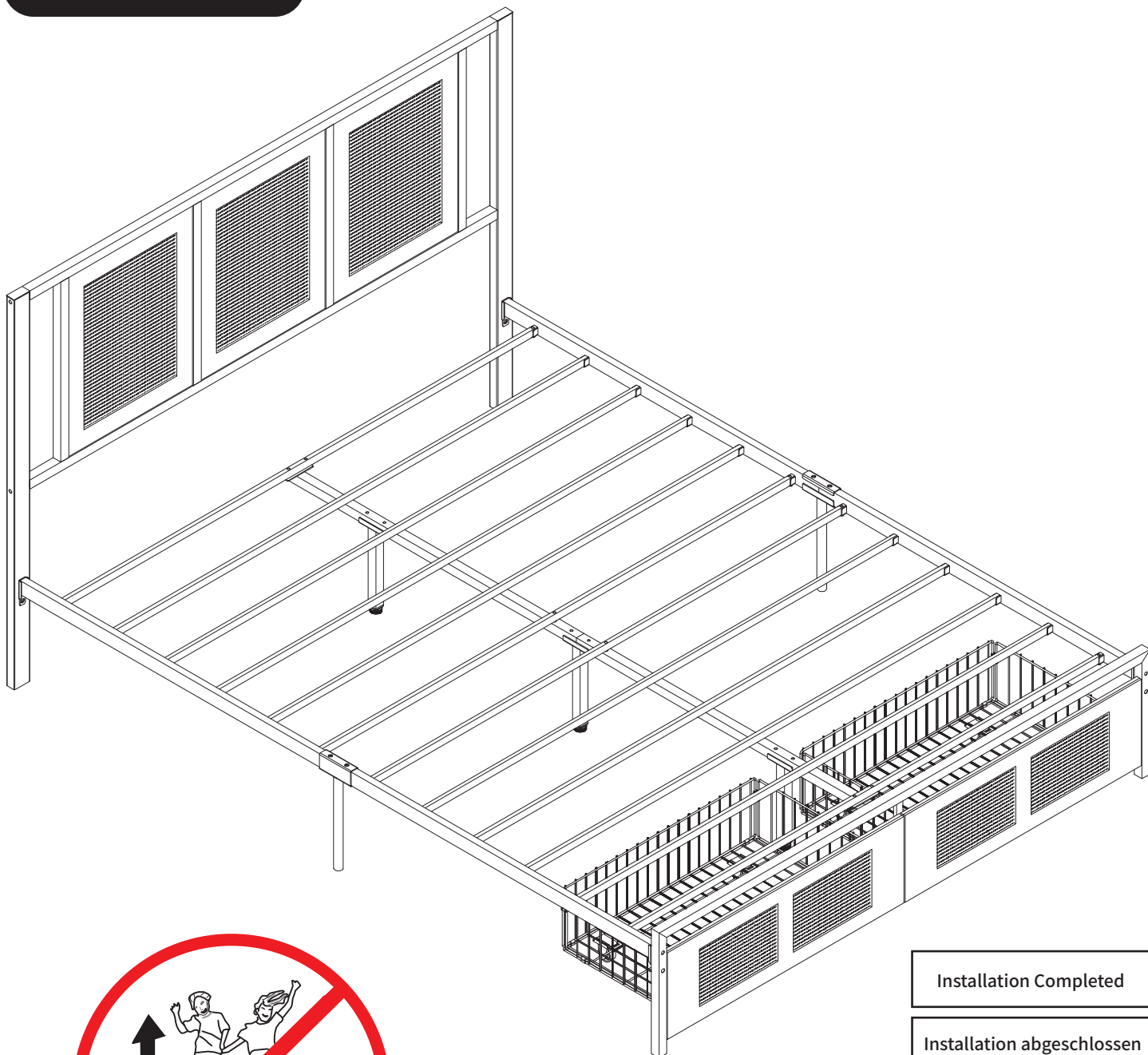

Installation Completed

Installation abgeschlossen

Installation complétée

Installazione completata

Instalación completada