

# Assembly Instructions

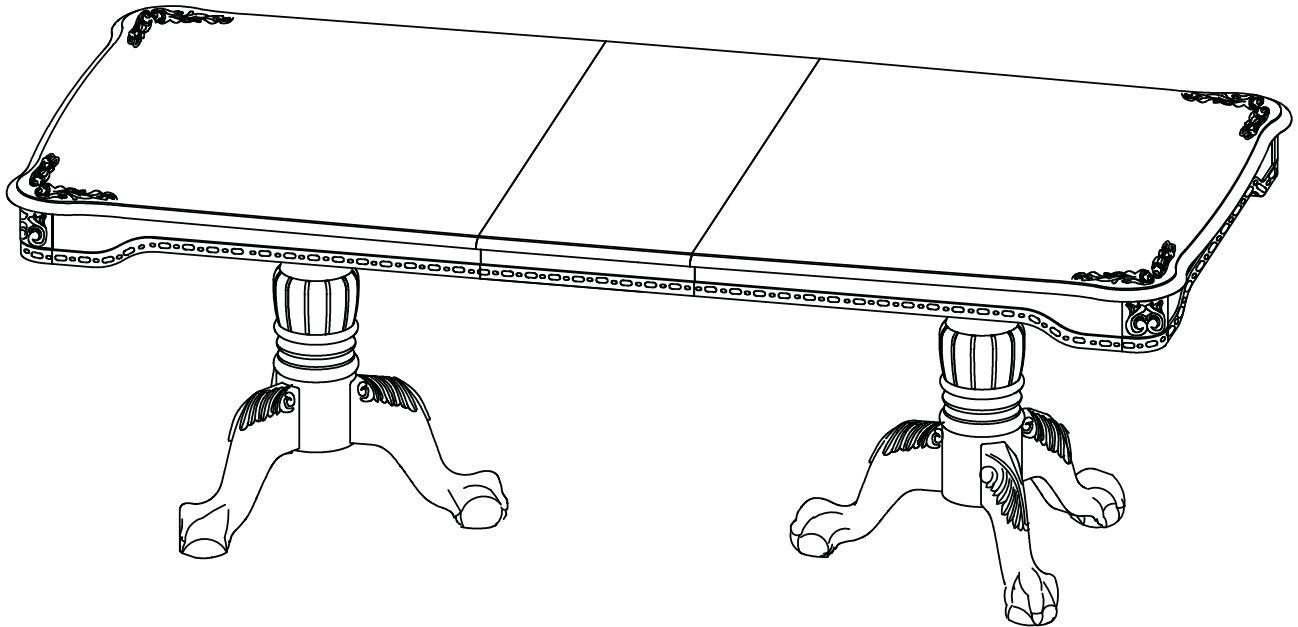

## ASSEMBLY RATING

The Assembly Rating is a 5-point system that shows the degree of effort needed in assembling a specific product (with 1 being easy and 5 being difficult). For some products, two persons are recommended.

EASY  DIFFICULT

## Tools Required For Assembly:

Allen Wrench

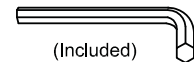

(Included)

Wrench



(Included)



2 PERSONS RECOMMENDED

# ASSEMBLY & CARE ADVICE

FOR YOUR FURNITURE TO LAST, CORRECT ASSEMBLY AND PROPER MAINTENANCE ARE NECESSARY. PLEASE FOLLOW THE INFORMATION PROVIDED BELOW TO FULLY ENJOY YOUR FURNITURE.

## BASIC ASSEMBLY TECHNIQUES

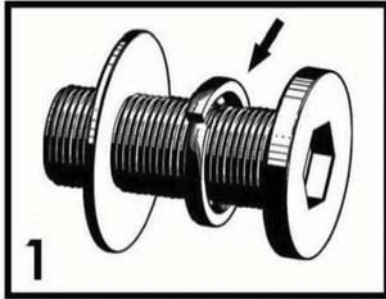

1 When lock or spring washer is used in an assembly, please make sure the lock or spring washer is placed between the larger flat washer and the head of the screw or bolt.



2 Position each part correctly and insert screws or bolts into their respective holes by hand tighten or using the proper hand tool. Only tighten when step is completed or when instructed to do so.

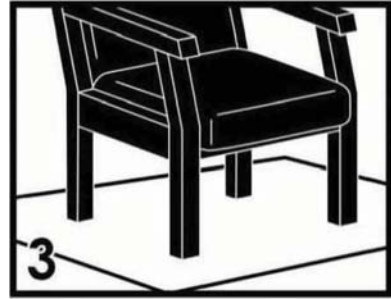

3 Use cardboard or carpet area when assembling furniture to prevent scratches. Make sure the furniture rests on a flat and level surface with each leg evenly touching the floor.

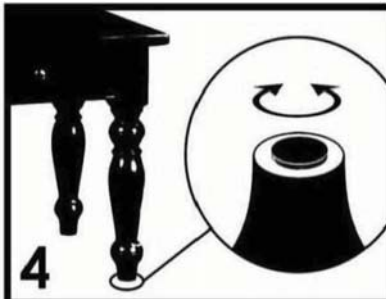

4 Some furniture comes with height adjustment knobs underneath each leg. To lower or to raise each leg, you need to turn clockwise or counterclockwise, respectively.

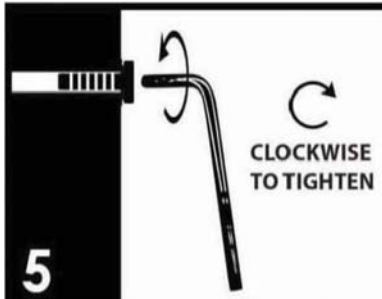

5 Make sure all parts are properly aligned, then use the appropriate hand tool to completely tighten the bolts or screws. Do not use power tools and do not overtighten.

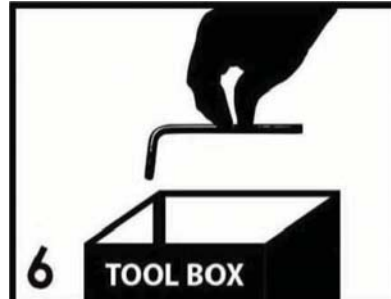

6 Save the instructions and store the Allen wrench or any supplied tool for later maintenance. After two weeks, check and tighten any loose hardware and repeat again every six months thereafter.

IT IS THE USER'S RESPONSIBILITY TO MAINTAIN THE FURNITURE. THE HARDWARE MAY LOOSEN OVER TIME AND MAY CAUSE THE FURNITURE TO BE WOBBLY AND UNABLE TO SUPPORT ITS INTENDED WEIGHT CAPACITY. THIS MAY LEAD TO COLLAPSE AND MAY CAUSE SERIOUS INJURY.

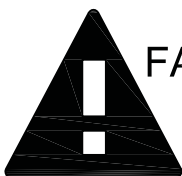



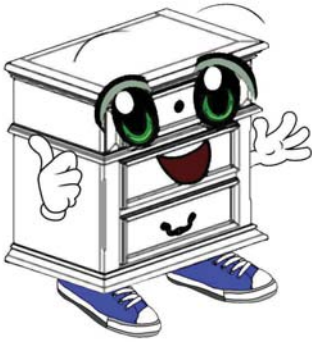

FAILURE TO FOLLOW THE GUIDELINES ABOVE MAY RESULT IN INJURY AND/OR PROPERTY DAMAGE.





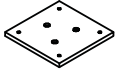
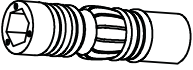

Before you begin, please read Page 2 of "Assembly and Care Advice".

And remember, do not tighten until each step is completed or instructed.

### Parts List

-  #1 x 1pc  
Table Top
-  #2 x 1pc  
Leaf
-  #3 x 2pcs  
Support Panel
-  #4 x 2pcs  
Pedestal
-  #5 x 6pcs  
Bottom Leg

### Hardware List

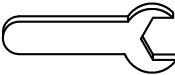
-  #A x 14pcs  
Bolt 5/16"X1-1/2"
-  #B x 26pcs  
Lock Washer
-  #C x 26pcs  
Flat Washer
-  #D x 1pc  
Allen Wrench
-  #E x 12pcs  
Helix 5/16"
-  #F x 1pc  
Wrench



#1

#E x 12PCS  
#B x 12PCS  
#C x 12PCS

1. Place the pedestal (#4) face down.

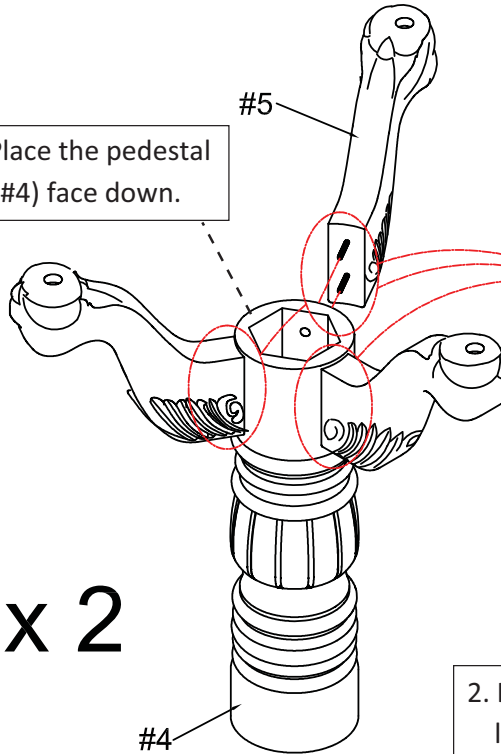

x 2

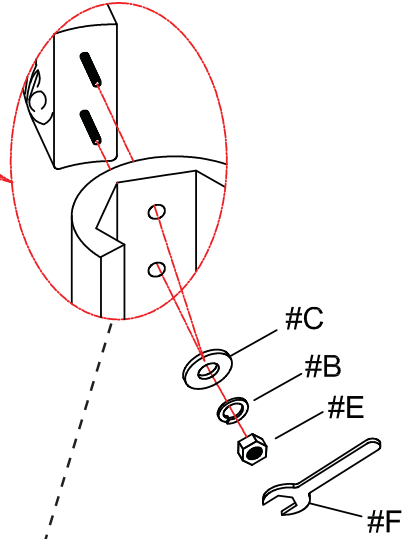

2. Insert the threaded ends along the bottom legs (#5) into the holes located around the pedestal (#4), then apply a flat washer (#C), lock washer (#B) and a hex nut (#E) in that order onto the ends. Secure using the wrench.



#2

#A x 6PCS  
#B x 6PCS  
#C x 6PCS

2. Place the support panel (#3) onto the top of the pedestal (#4) and align the holes.

1. Turn the pedestal (#4) face up.

x 2

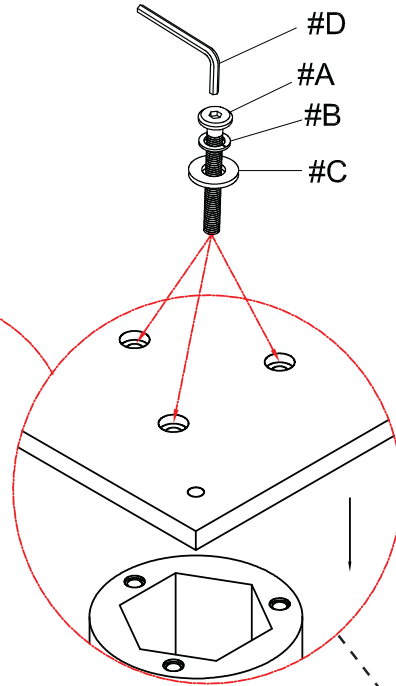
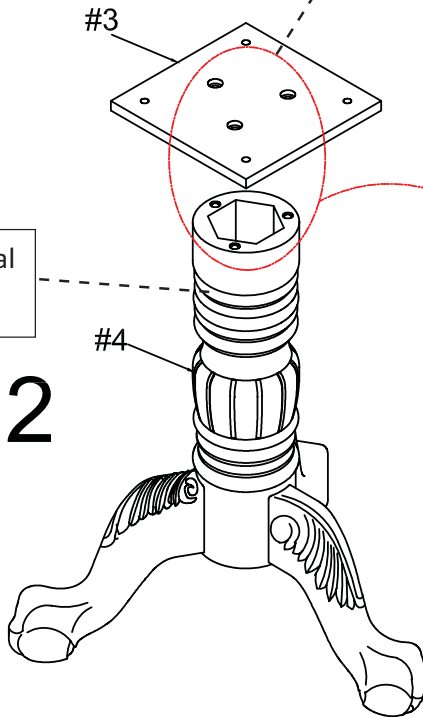

3. Prepare 6 bolt assemblies by first inserting a lock washer (#B) onto the bolt (#A) then a flat washer (#C) onto that same bolt (#A). Insert 3 into the center of each support panel (#3). Secure using the Allen wrench.



#3

1. Place the table top (#1) face down onto a protected surface, then place the pedestals (#4) face down onto the table top.

#A x 8PCS  
#B x 8PCS  
#C x 8PCS

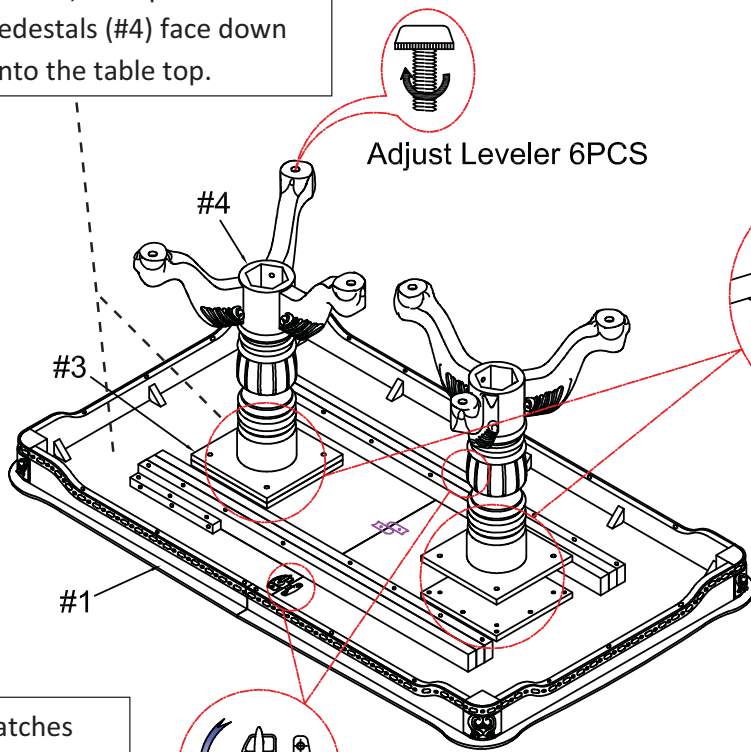

Adjust Leveler 6PCS

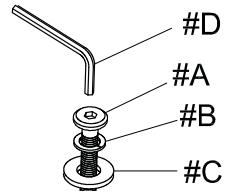

2. Prepare 6 bolt assemblies by first inserting a lock washer (#B) onto the bolt (#A) then a flat washer (#C) onto that same bolt (#A). Insert 4 bolts into each pedestal (#4). Secure using the Allen wrench.

3. Unlock the latches located on the bottom of the table top.



#4

1. Push the outer sides of the table top (#1) outward.

2. Place the leaf (#2) onto the center of the railing.

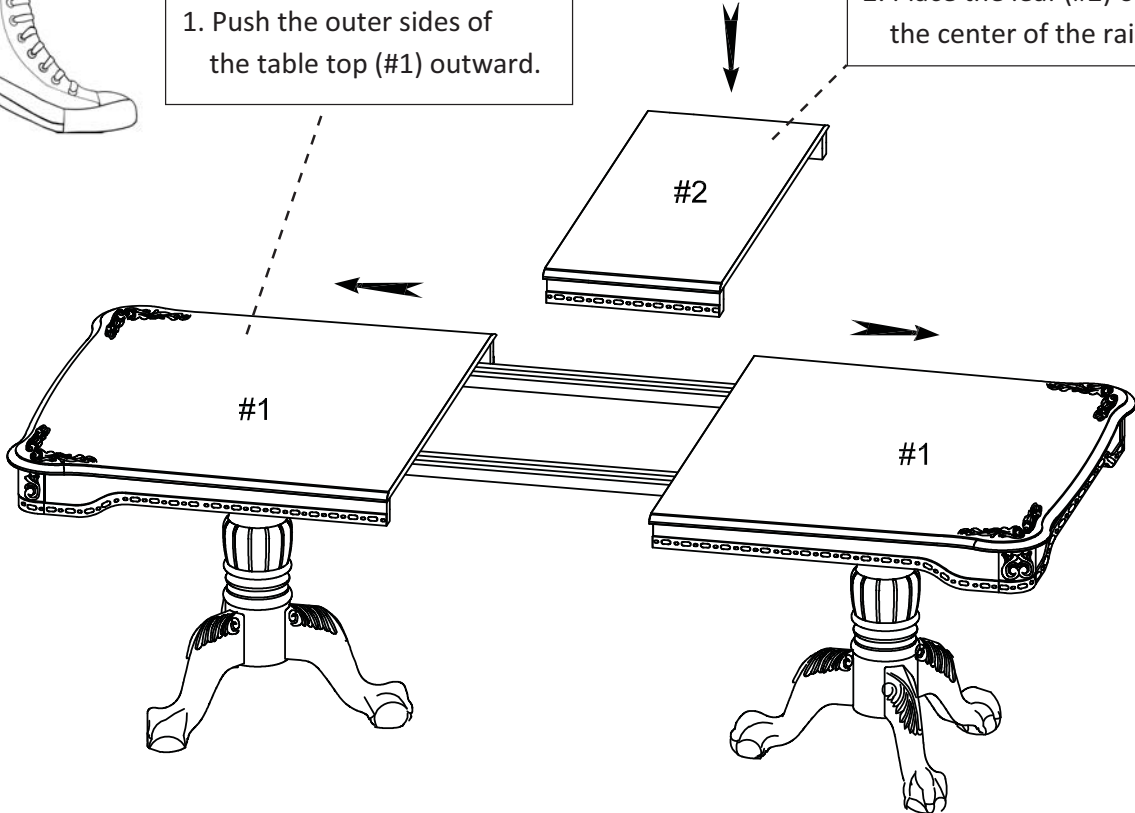

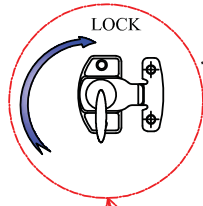

Slide the outer ends of the table top (#1) inwards and secure the latches.

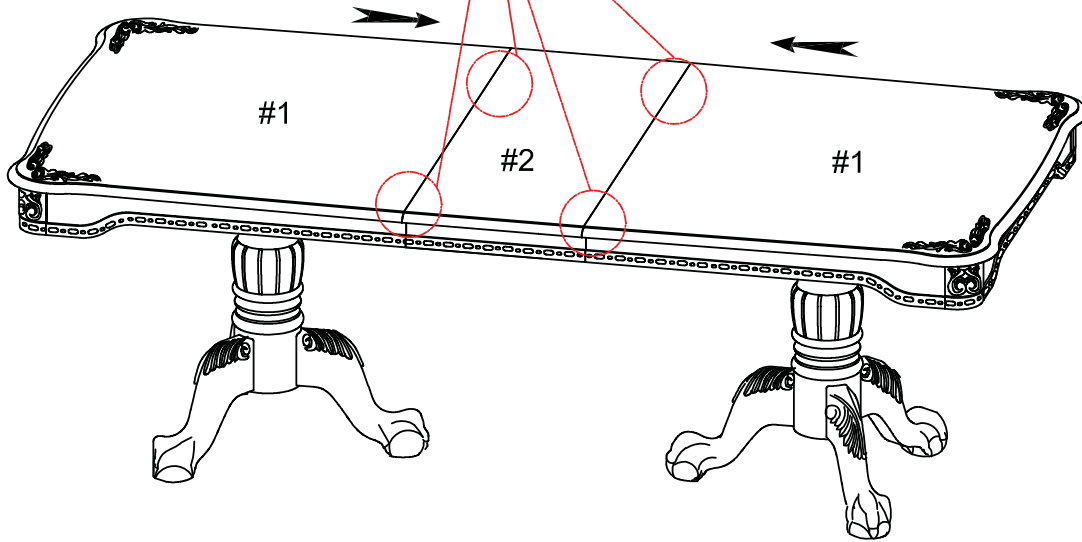

Make sure all parts are firmly secured.

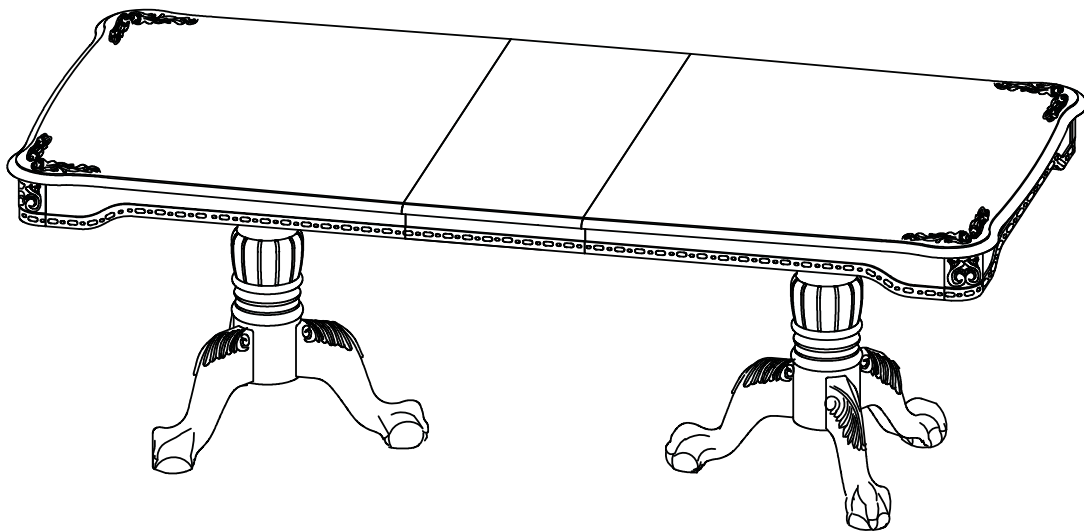

ASSEMBLY IS COMPLETED