

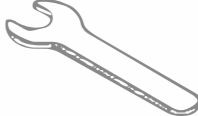
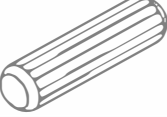





Illustration of Installation

Part name / Teilname / Noms des pièces du produit / Nome della parte / Nombre de la pieza								
NO.	English	Deutsch	Français	Italiano	Español	Parts drawing	Size	Amount
1	Panel	Platte	Panneau	Pannello	Panel		1200*300*20MM	1
2	Side Frame	Seitenrahmen	Cadre latéral	Telaio laterale	Marco lateral		740*290*53MM	2
3	Intermediate plate	Zwischenplatte	Plaque intermédiaire	Piastra intermedia	Placa intermedia		960*75*20MM	1
A	Hexagon socket screw	Innensechskantschraube	Vis à six pans creux	Vite a brugola	Tomillo de hexágono interior		M6*35MM	4
B	Flat gasket	Unterlegscheibe	Rondelle plate	Rondella piana	Arandela plana		M6*13MM	4
C	Allen key	Inbusschlüssel	Clef hexagonale	Chiave esagonale	Llave Allen		M4*100*40MM	1
D	Full-tooth screw	Vollgewindeschraube	Vis à filetage complet	Vite a filettatura completa	Tomillo de rosca completa		M6*80MM	2
E	Crescent shims	Halbmondförmige Distanzscheiben	Cales en demi-lune	Spessori a mezzaluna	Calzas en forma de media luna		M8*14*27*6MM	2

Caution: After unpacking, check the correct number of accessories against the instructions.

Illustration of Installation

Part name / Teilname / Noms des pièces du produit / Nome della parte / Nombre de la pieza								
NO.	English	Deutsch	Français	Italiano	Español	Parts drawing	Size	Amount
F	Hexagon nuts	Sechskantmuttern	Écrous hexagonaux	Dadi esagonali	Tuercas hexagonales		M6*10MM	2
G	Open-end wrench	Maulschlüssel	Clé plate	Chiave a bocca	Llave fija		M10	1
H	Wood tenon	Holzdübel	Tenon en bois	Tenone in legno	Espiga de madera		ø8*30MM	2
I	Hex socket screw	Innensechskantschraube	Vis à six pans creux	Vite a brugola	Tornillo de hexágono interior		M6*50MM	3
J	Adjustable feet	Verstellbare Füße	Pieds réglables	Piedini regolabili	Patas ajustables		M6*Ø19*5MM	4
K	Anti-tip Hardware Kit	Kippschutz-Beschlagsatz	Kit de fixation anti-basculement	Kit ferramenta anti-ribaltamento	Kit de herrajes antivuelco		/	1
L	Flat gasket	Unterlegscheibe	Rondelle plate	Rondella piana	Arandela plana		M6*11MM	3

Caution: After unpacking, check the correct number of accessories against the instructions.

This product is fully compliant with the national quality inspection standards by wood inspection, paint inspection, qualified and given to the factory, to confirm that the packaging is intact for sale.	Product Category Name	Solid Wood Furniture	Quality Inspector	Implementation Standard:
	Qualification	Pass	QC 02	GB/T 3324
	Grade	Class 1		GB/ 18584

Installation Overview

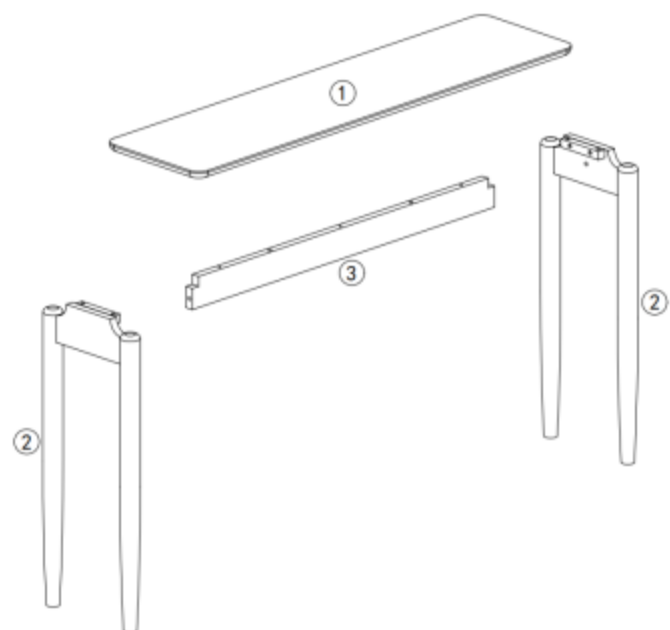

Step 1 / Schritt 1 / Étape 1 / Passo 1 / Paso 1 :

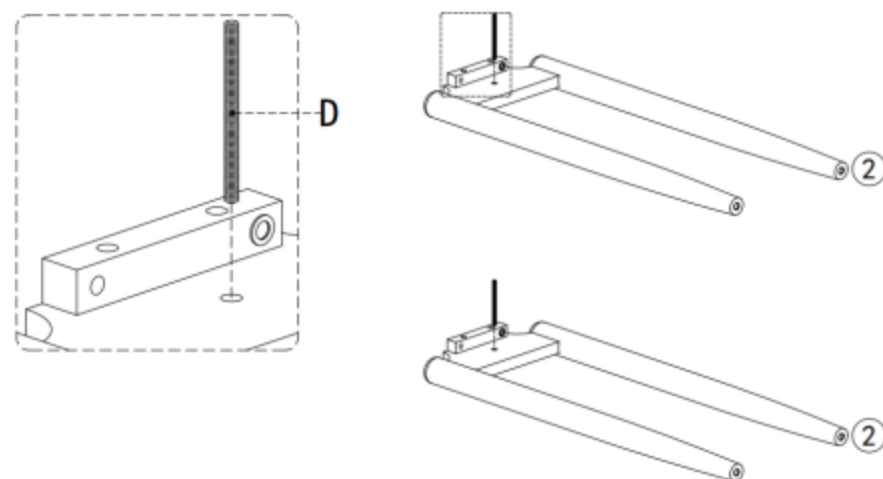

D		2PCS
---	--	------

Step 2 / Schritt 2 / Étape 2 / Passo 2 / Paso 2 :

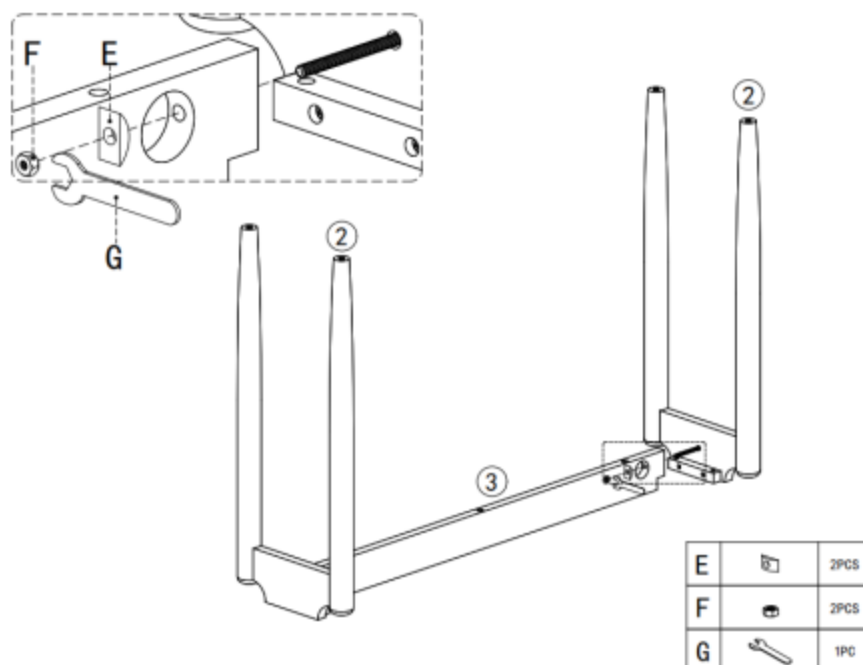

E		2PCS
F		2PCS
G		1PC

Step 3 / Schritt 3 / Étape 3 / Passo 3 / Paso 3:

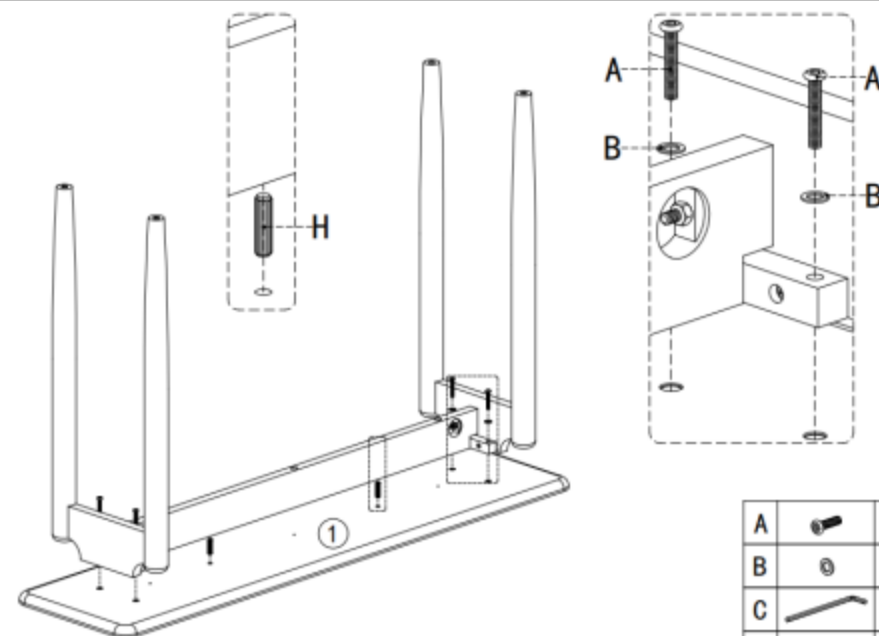

A		4PCS
B		4PCS
C		1PC
H		2PCS

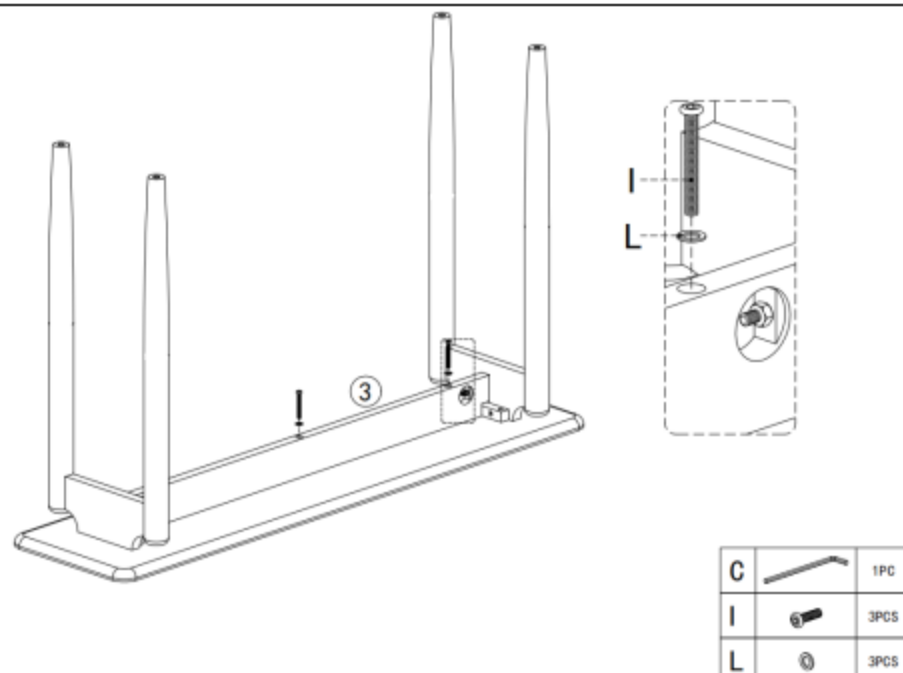
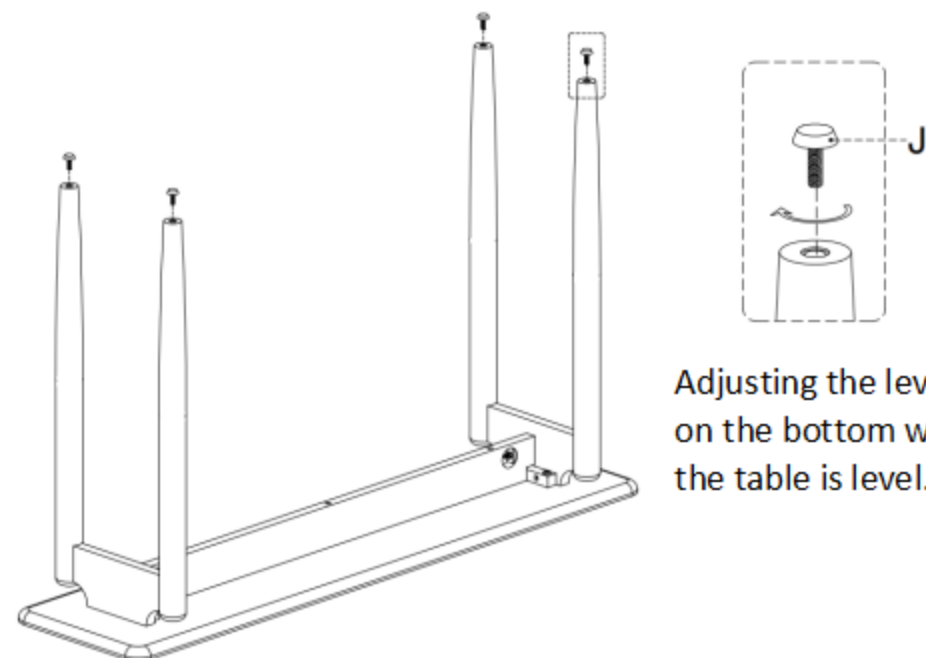
Step 4 / Schritt 4 / Étape 4 / Passo 4 / Paso 4:**Step 5 / Schritt 5 / Étape 5 / Passo 5 / Paso 5 :**

Adjusting the leveling pads on the bottom will ensure the table is level.

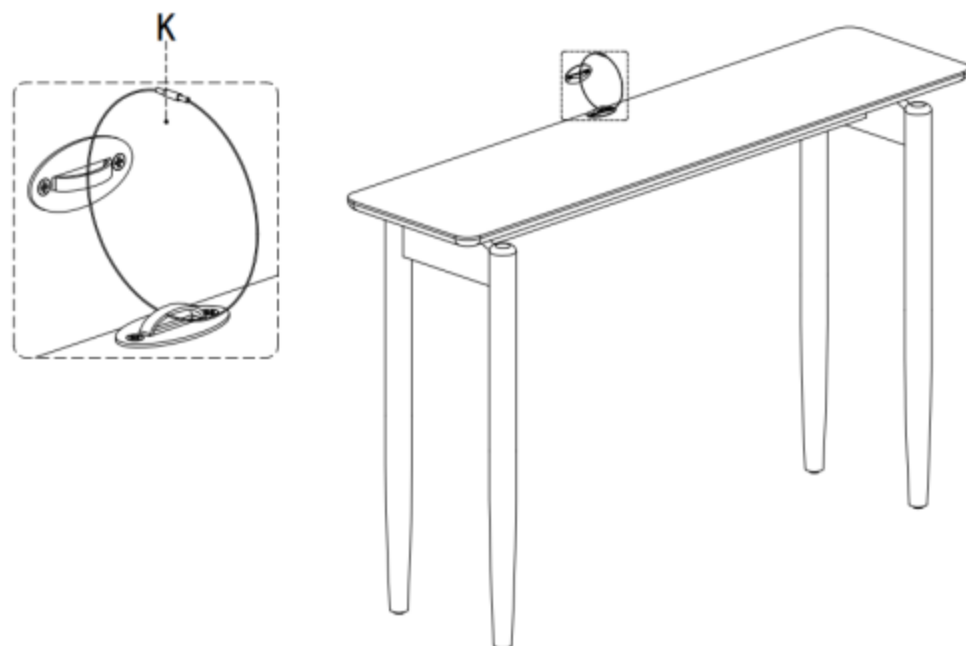
Step 6 / Schritt 6 / Étape 6 / Passo 6 / Paso 6:

English:As shown in the diagram: Move the table to the wall position, then secure it to the wall using hardware K to prevent tipping and injury. Assembly complete.

Deutsch:Wie in der Abbildung gezeigt: Stellen Sie den Tisch an die Wand und befestigen Sie ihn anschließend mit dem Beschlag K an der Wand, um ein Umkippen und Verletzungen zu verhindern. Montage abgeschlossen.

Français:Comme indiqué sur le schéma : placez la table contre le mur, puis fixez-la au mur à l'aide du matériel K afin d'éviter tout basculement et risque de blessure. Assemblage terminé.

Italiano:Come mostrato nel diagramma: spostare il tavolo contro la parete, quindi fissarlo alla parete utilizzando la ferramenta K per evitare ribaltamenti e infortuni. Montaggio completato.

Español:Como se muestra en el diagrama: coloque la mesa contra la pared y luego fijela a la pared utilizando el herraje K para evitar vuelcos y lesiones. Montaje completado.