

# ASSEMBLY INSTRUCTIONS

## Lewis Coffee Table

ASSEMBLY

2 HOURS

2 -Person Assembly

Tools Required (Not Provided):

REQUIREMENTS

Assembly Time

(Approximate)

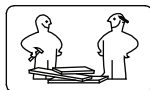

Phillips Screwdriver

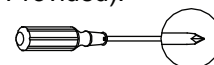

Flat-head Screwdriver

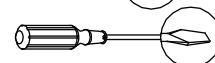

### Thank you for purchasing our product!

Please refer and use this assembly instruction to assemble the product.

Contact our customer service department in case there are any missing or damage parts or hardware.

Replacement parts are normally shipped within 2 or 3 days.

### ASSEMBLY PREPARATION

1. Remove all packaging materials, staples and packing straps from the carton.
2. Refer to Parts List and Hardware List and ensure they are complete before you start assembling.
3. Place all wooden parts on a clean, flat and soft surface (e.g. carpet or rug) to prevent parts from getting scratched.

### SAFETY PRECAUTION:

1. KEEP ALL HARDWARE PARTS OUT OF REACH OF CHILDREN.
2. DISPOSE PLASTIC PACKAGING MATERIAL IMMEDIATELY TO AVOID ANY RISK OF SUFFOCATION TO CHILDREN AND ANIMALS.

### TIPS FOR ASSEMBLY:

1. Allow ample room for assembly and in close proximity to where product will be placed.
2. Assemble the product on a surface that does not scratch or damage the exterior gloss and finish of the furniture.
3. Please check all of the parts and quantities are included before assembly. Contact customer service for missing parts.
4. Identify all of the parts, hardware and quantities required for each step.
5. During assembly, do not over-tighten any fittings as this may cause damage.
6. DO NOT USE POWER TOOLS TO ASSEMBLE THIS PRODUCT.
7. Always place the product on a flat surface.
8. Do not sit or stand on the partially assembled product; only use the product for which it is intended.

### CARE AND MAINTENANCE

- Use a slightly damp cloth to clean the product. Do not use bleach or abrasive cleaning material.
- Check all the fittings periodically and re-tighten as necessary. Do not use the product if any of the parts is damaged or broken.
- Never allow any kind of liquid to remain on your furniture. Absorption can cause wood to warp or delaminate.
- Do not place hot items (e.g. hot drinks) directly onto the wood surface.
- Do not drag and/or pull the furniture.







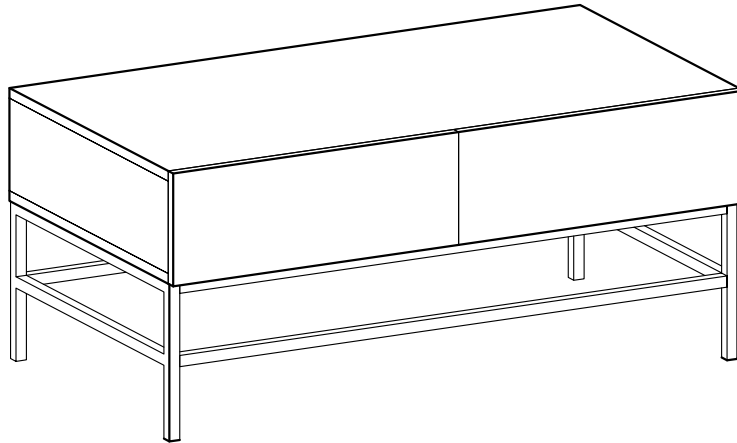

This product is for indoor and household-use only - not for commercial use.

# ASSEMBLY INSTRUCTIONS

## Lewis Coffee Table/Coffee Table



### Hardware List

ITEM	DESCRIPTION	PART	QTY	ITEM	DESCRIPTION	PART	QTY
A	Cam-lock	 14*11mm	28PCS	F	Screw	 4*12 mm	16PCS
B	Cam-bolt	 5*40 mm	28PCS	G	Metal Glide		2 sets
C	Flat Washer	 6*16 mm	22PCS	H	Screw	 4*35mm	8PCS
D	Allen-Head Bolt	 6*15 mm	22PCS	I	Wood dowel	 8*40mm	12PCS
E	Allen Wrench		1PC				

# CAM-BOLT and CAM-LOCK INSTRUCTIONS

## CAM-LOCK



Align the arrow on the Cam-lock to the Cam-bolt head and insert the Cam-lock.

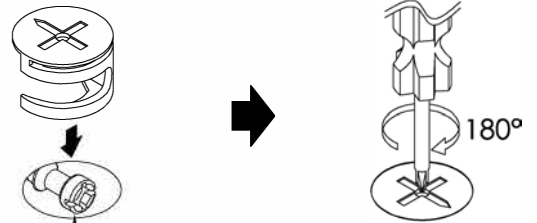
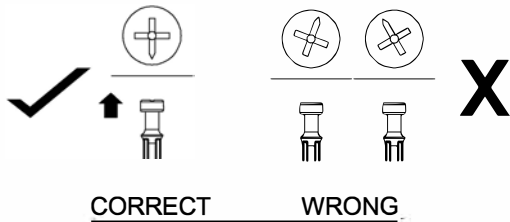

Use a flat screwdriver to turn the Cam-Lock clockwise one half a turn so it locks onto the head of the Cam-lock. Turn only until it is snug – over-tightening could damage Cam-lock or/and Cam-bolt

## CAM-BOLT

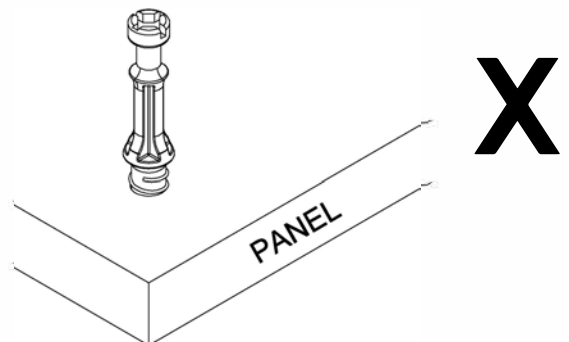
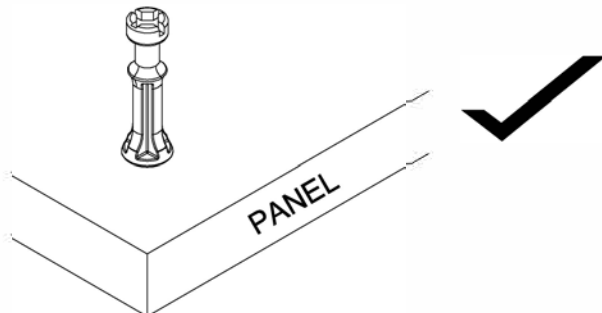
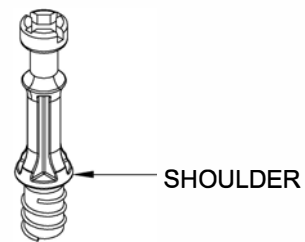

Insert Cam-bolt into the pre-drilled hole. Use a Phillips Screwdriver to tighten until shoulder is flush with the panel. See illustrations below.

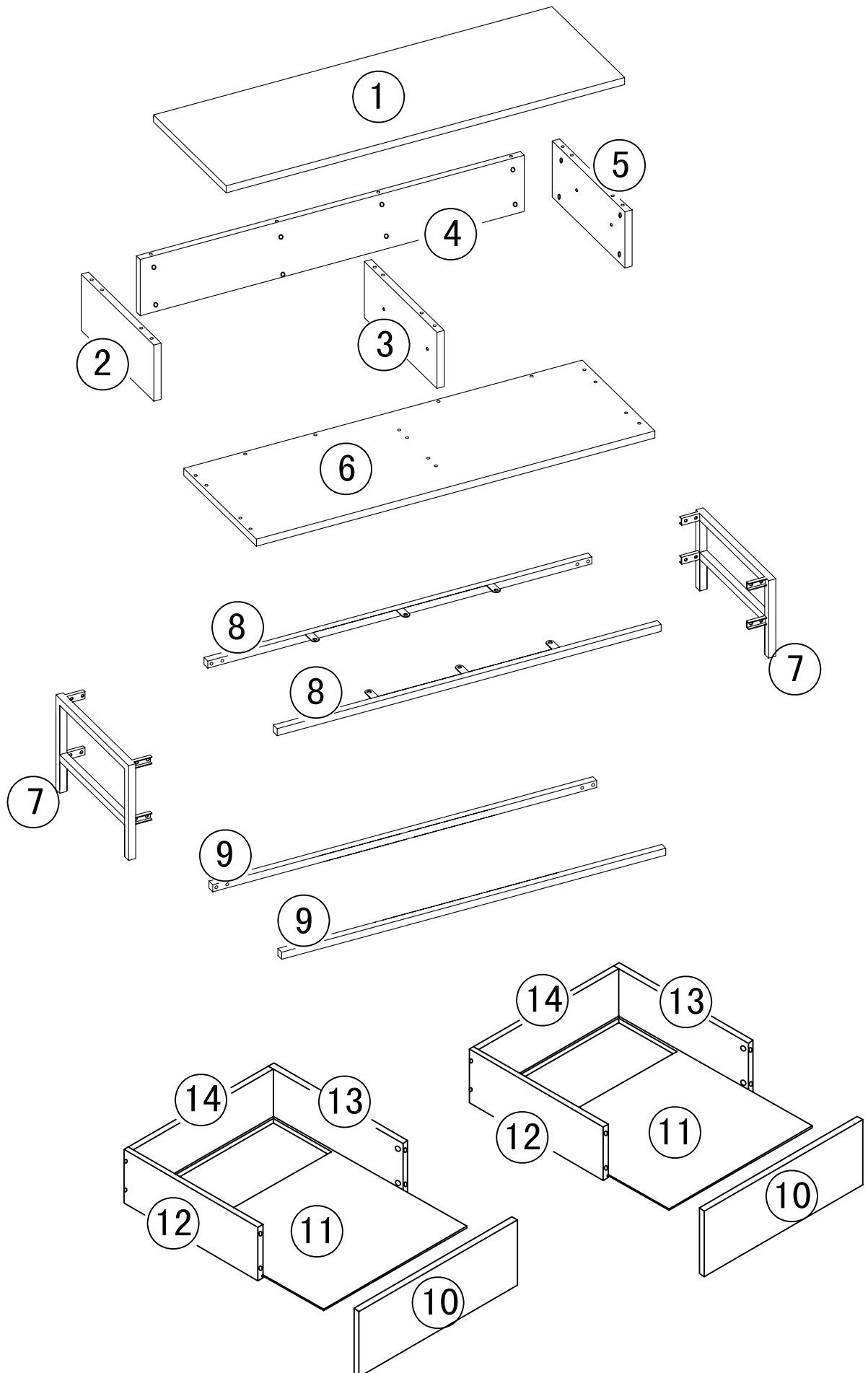

# Parts & Assembly Overview

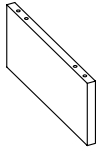
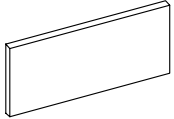
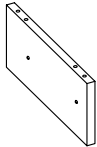
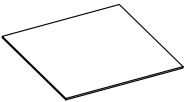
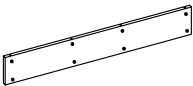
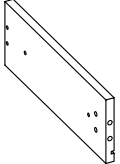
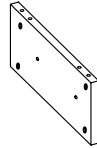
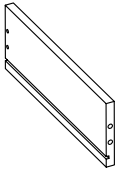
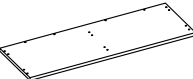
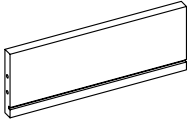
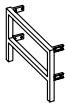
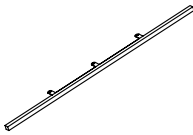

# Parts List

ITEM	DESCRIPTION	PART	QTY	ITEM	DESCRIPTION	PART	QTY
1	Top Panel		1 PC	9	Connect Base		2 PCS
2	Left Side Panel		1 PC	10	Drawer Front Panel		2 PCS
3	Divide Panel		1 PC	11	Drawer Bottom Panel		2 PCS
4	Back Panel		1 PC	12	Drawer Left Side Panel		2 PCS
5	Right Side Panel		1 PC	13	Drawer Right Side Panel		2 PCS
6	Bottom Base		1 PC	14	Drawer Back Panel		2 PCS
7	Leg		2 PCS				
8	Connect Base		2 PCS				

# STEP 1

1. Distinguish Metal Glide (G) between Part A and Part B.

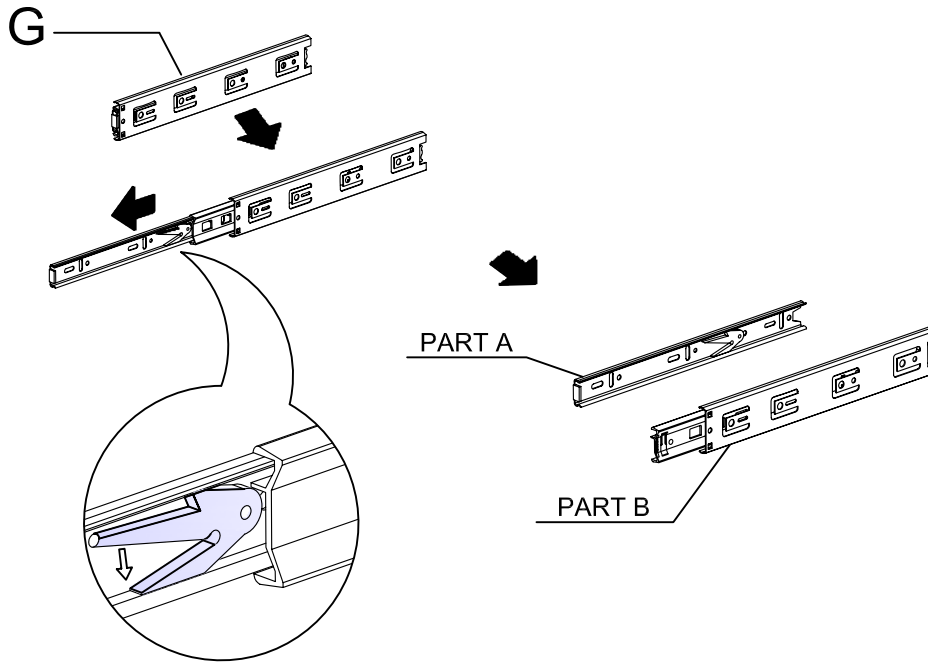

G		2 sets
---	---	--------



Push Lever downwards to slide out Part A

# X 4

# STEP 2

A		8 pcs
B		8 pcs

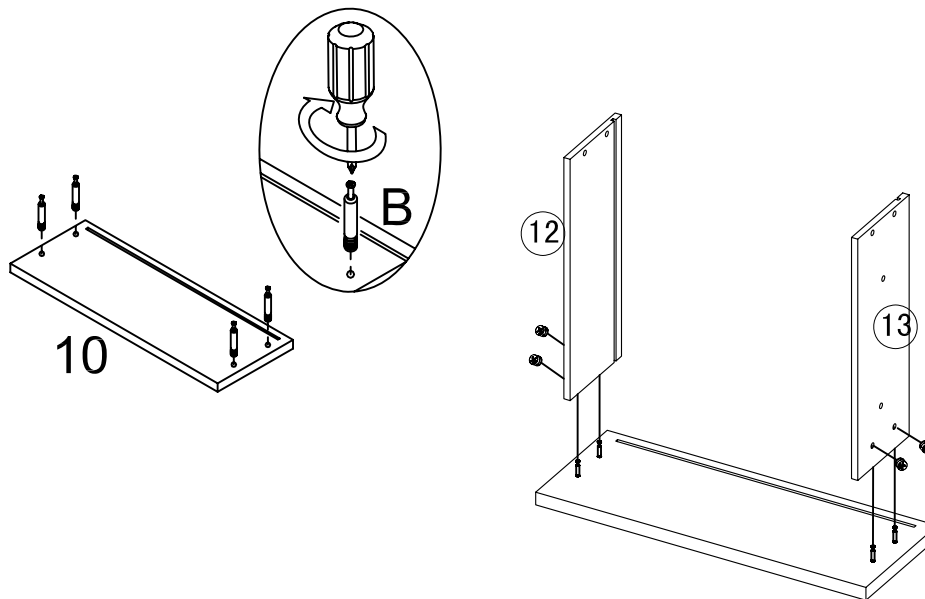

  
DO NOT USE POWER TOOLS

1. Attach Cam-bolt (B) to Drawer Front Panel (10).  
(Refer to page on Cam-bolt and Cam-lock Instructions)
2. Attach Drawer Front Panel (10). Next, insert Cam-lock (A) then turn clockwise to lock Cam-bolt in place. (Refer to page on Cam-bolt and Cam-lock Instructions.)

# X 2

# STEP 3

H		8 pcs
---	---	-------

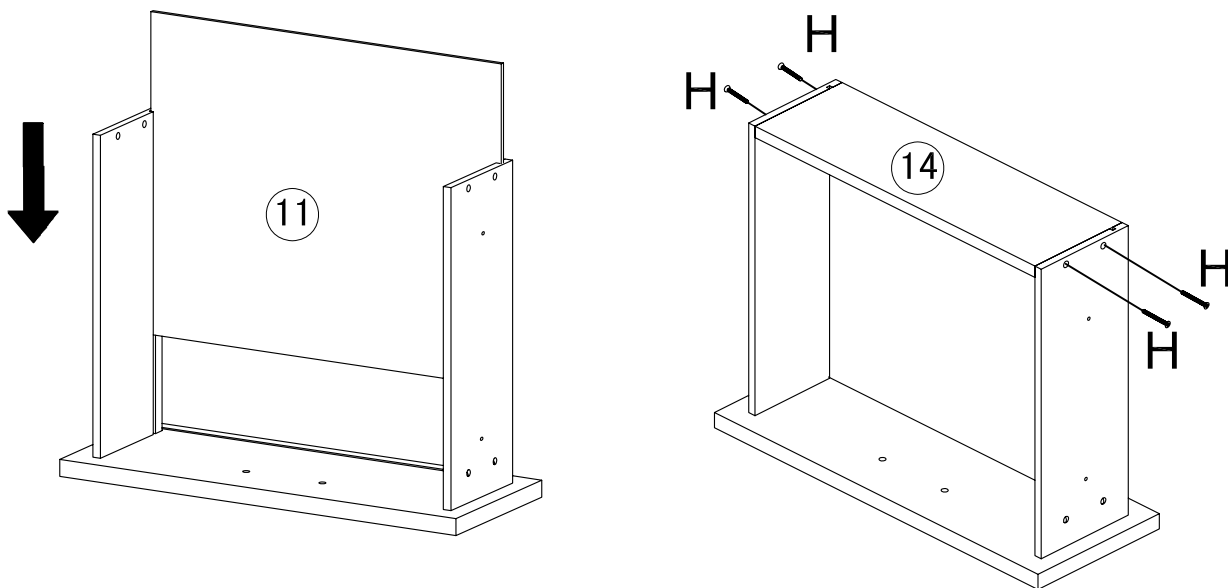

1. Insert Drawer Bottom Panel (11 ) by fitting (11) into the groove on Drawer Front & Side Panels.

2. Attach Drawer Back Panel (14) to Drawer Side Panel (12 & 13) by using Screw (H).

(Check that Bottom Panel (11) fits into the groove on Back Panel before fastening)

# X 2

# STEP 4

F		8 pcs
---	---	-------

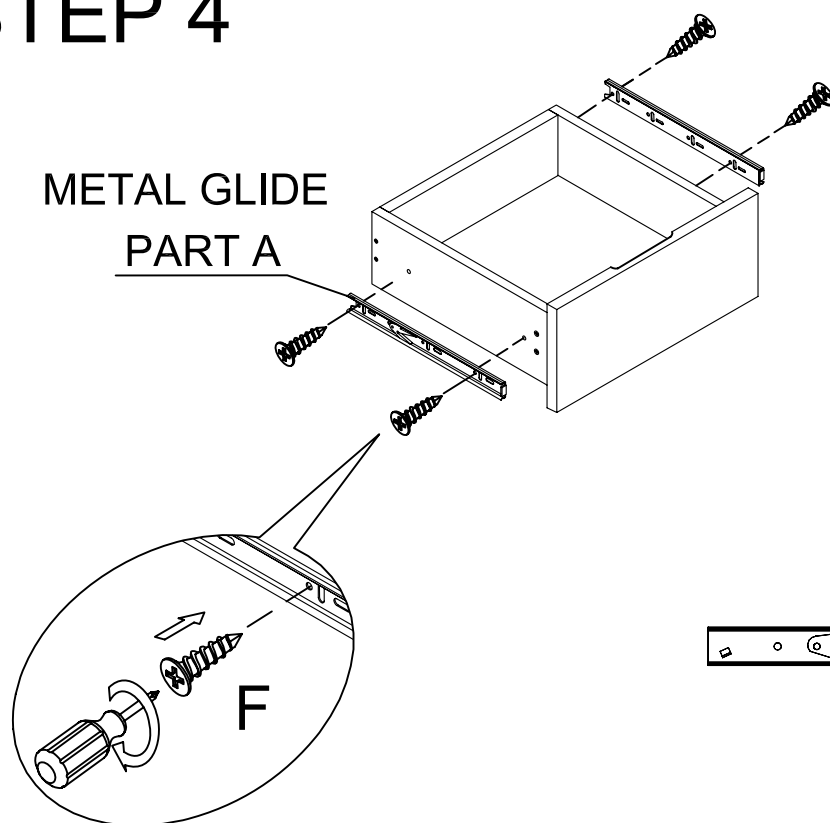

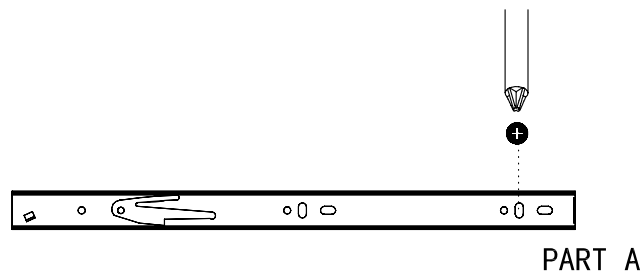

  
DO NOT USE POWER TOOLS



1. Install Part A of Metal Glide (G) to pilot holes on drawer by using Screw (F).

# X 2

# STEP 5

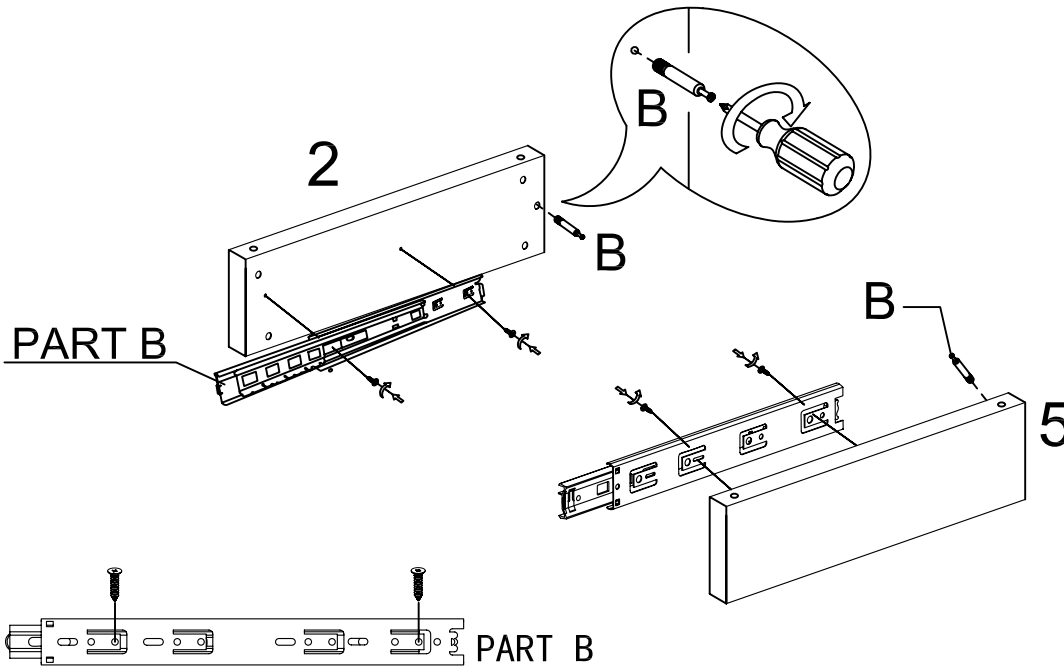

F		4 pcs
B		2 pcs



DO NOT USE POWER TOOLS

1. Install Part B of Metal Glide (G) to Left Side Panel (2) and Right Side Panel (5) by using Screw (F) .
2. Screw in Cam-bolt (B) to Left Side Panel (2) and Right Side Panel (5) (Refer to page on Cam-bolt and Cam-lock Instructions.)

# STEP 6

A		10 pcs
B		10 pcs
I		6 pcs

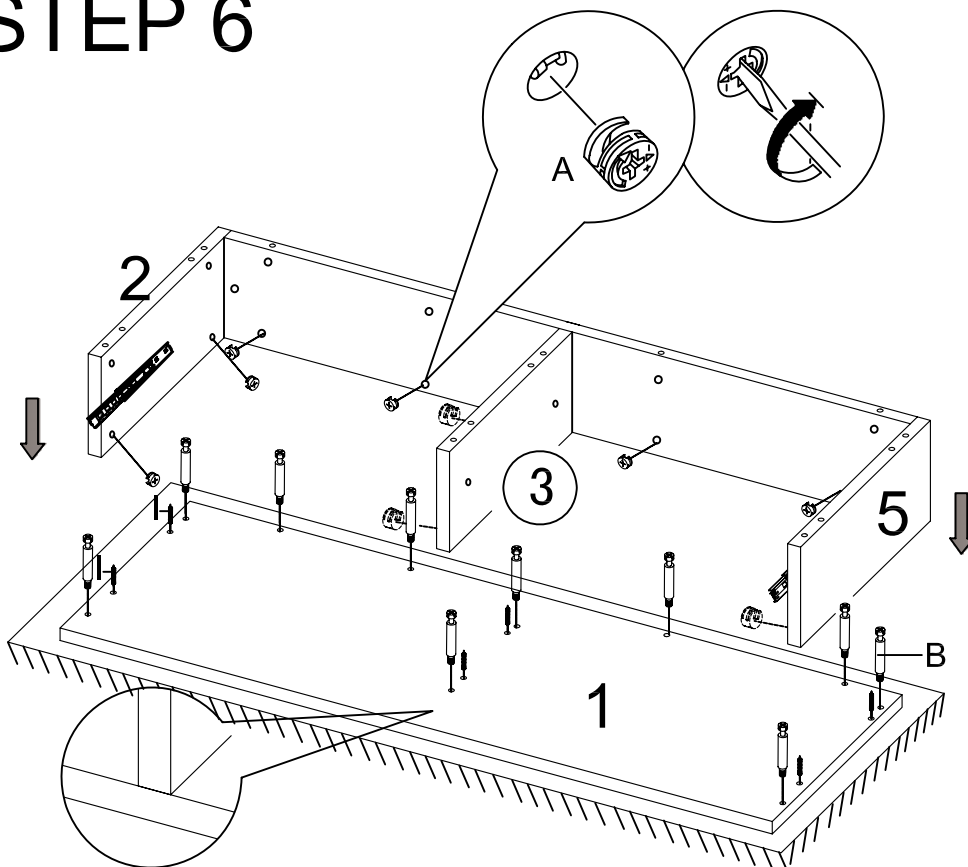

DO NOT USE POWER TOOLS

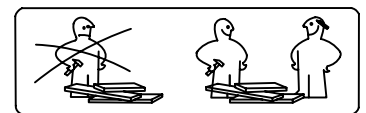

Refer to page on Cam-bolt and Cam-lock Instructions.

1. Attach Cam-bolt (B) & Wood dowel (I) to all of the pre-drilled holes on Bottom Base (6).
2. Align and fit Panel (2), (4) & (5) from Step 6 to Bottom Panel (6). Insert Cam-lock (A) to (2), (4) and (5) and turn Cam-lock clockwise to lock onto Cam-bolt (B).
3. Attach Divide Panel (3) to Bottom Panel (6) via Cam-bolts. Insert Cam-locks (A) to lock onto Cam-bolt (B)

# STEP 7

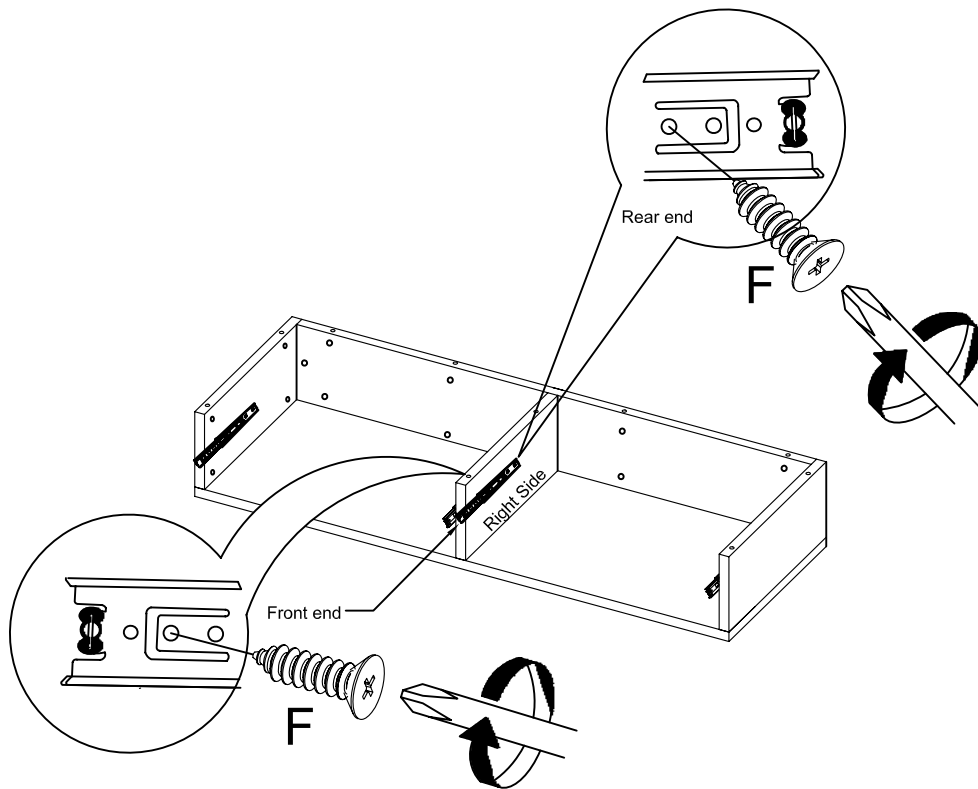

F		4 pcs
---	---	-------





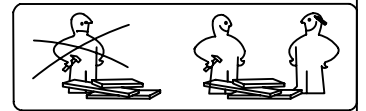

DO NOT USE POWER TOOLS

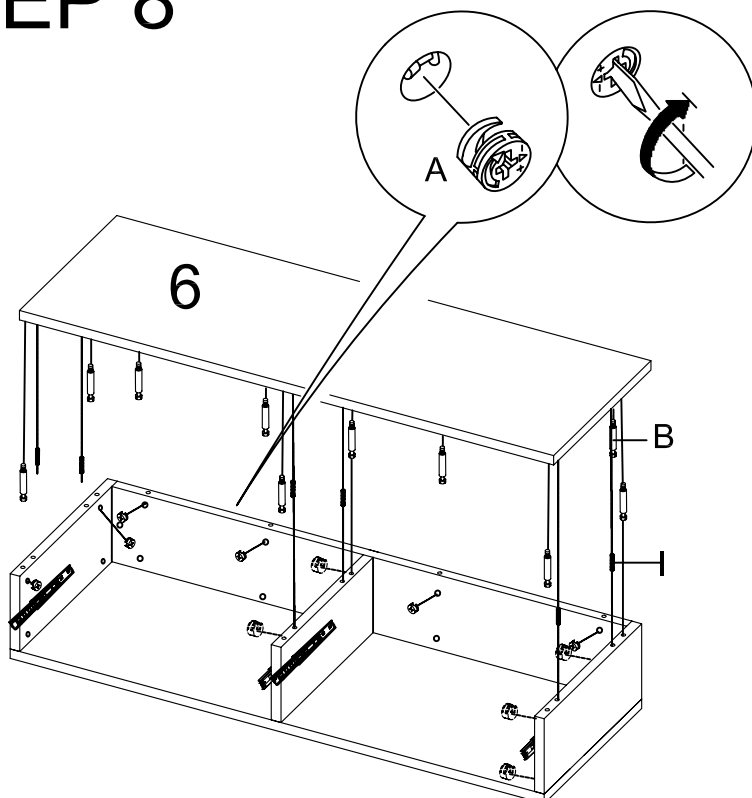

1. Install Part B of Metal Glide (G) to right side of Divide Panel (3): align 2nd hole on the Front End of Part B and 3rd hole on the Rear End of Part B to the pilot holes on (3). Use Screw (F) to fasten Part B to right side of (3).
2. Use the same procedure above to install Part B of Metal Glide (G) to left side of Divide Panel (3)

# STEP 8



A		10 pcs
B		10 pcs
I		6 pcs



DO NOT USE POWER TOOLS

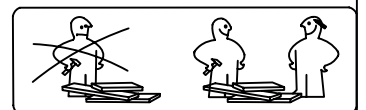

Refer to page on Cam-bolt and Cam-lock Instructions.

1. Insert and tighten Cam-bolt (B) & Wood dowel (I) to all of the pre-drilled holes on Top Panel (1).
2. Align and fit Top Panel (1) to (2), (3), (4) and (5) as shown.
3. Insert Cam-locks to (2), (3), (4) and (5) and turn Cam-lock clockwise to lock onto Cam-bolt (B).

# STEP 9

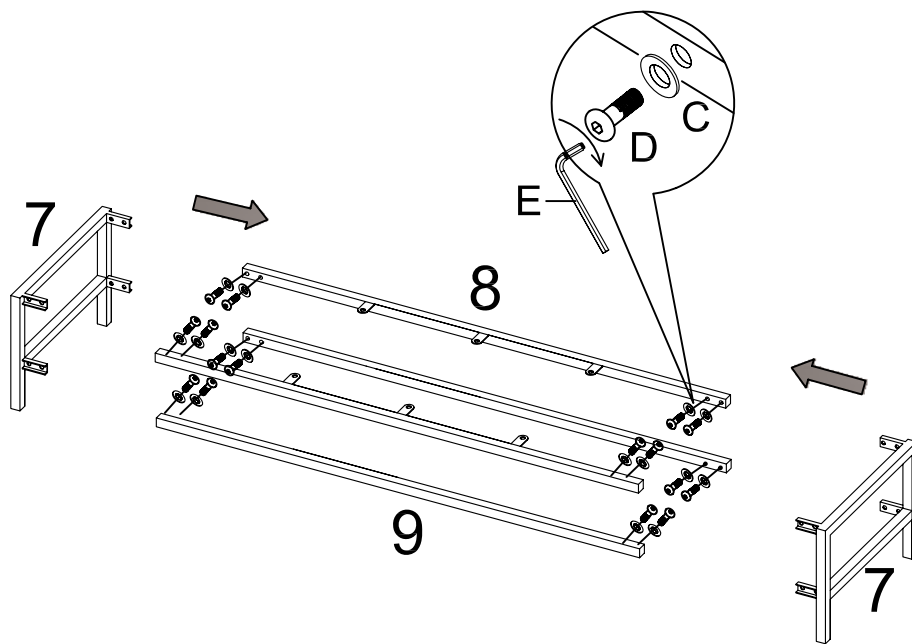

C		16 pcs
D		16 pcs
E		1pc



DO NOT USE POWER TOOLS

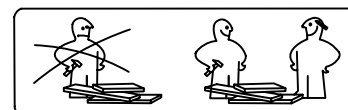

1. Attach Leg (7) to Connect Base (8) & Connect Base (9) by using Allen-Head Bolt (D) and Lock Washer (C).
2. Tighten Allen-head Bolt (D) with Allen Wrench (E). Do not tighten completely until all of the Bolts are in place.

# STEP 10

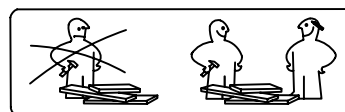

C		6 pcs
D		6 pcs
E		1pc

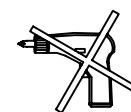

DO NOT USE POWER TOOLS

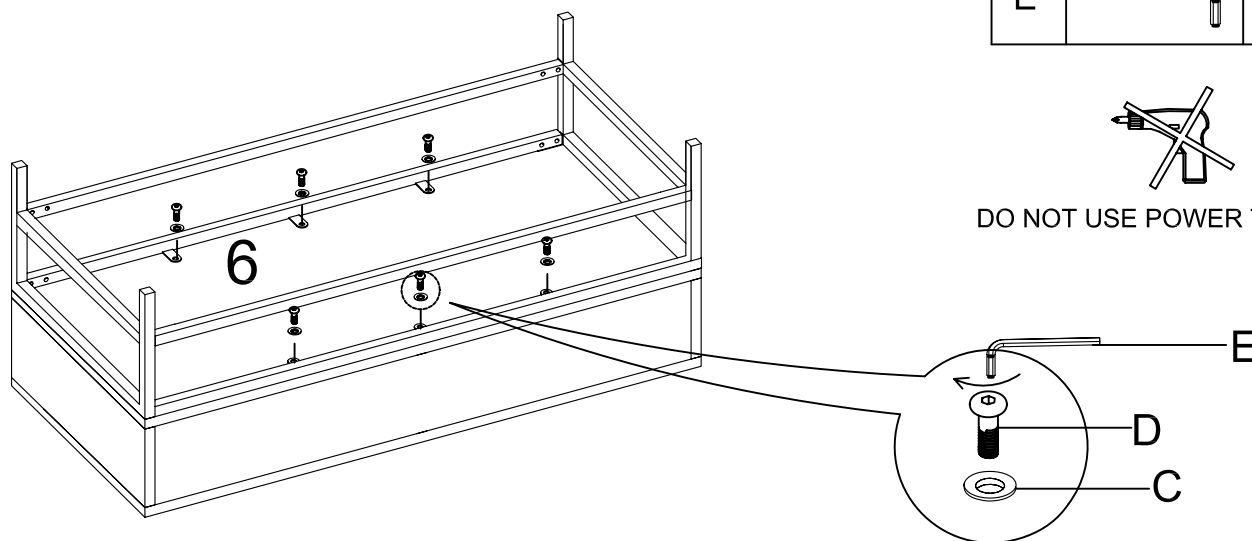

1. Place the sub-assembly completed in Step 9 bottom-side up with Bottom Base (6) face up.
2. Place Leg assembly from Step 10 bottom-side up and directly over Bottom Base (6) as shown.
3. Use Allen-Head Bolt (D) and Lock Washer (C) to attach Connect Base of Leg assembly to Bottom Base (6). Tighten the Bolt (D) by using Allen Wrench (E)

# STEP 11

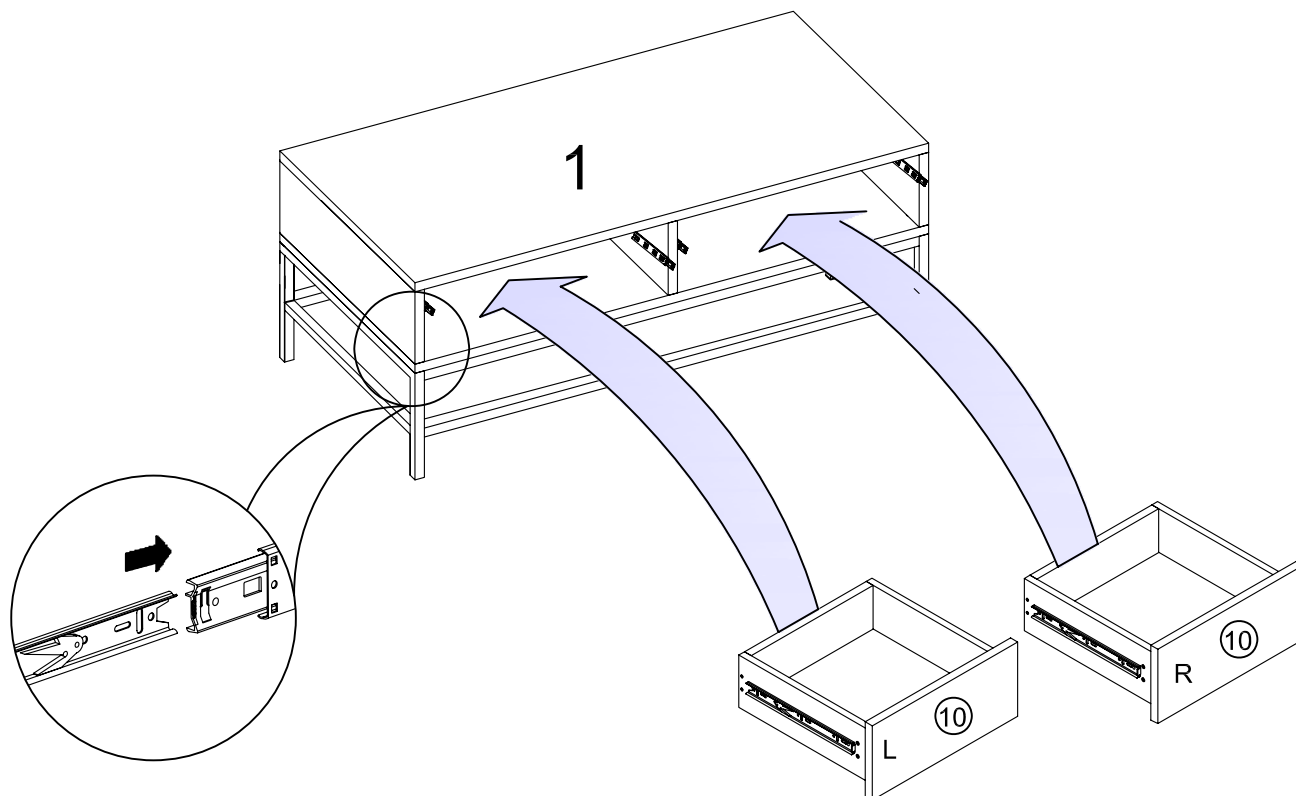

1. Insert drawers as shown.

# FINISH

