

Wood Platform Bed



Dear Customers,

Thank you for purchasing our product. Please read this instruction manual carefully after receiving this product. It will help you assemble this product quickly, safely and correctly. You can keep this manual for future reference.

! IMPORTANT

Please follow the instruction manuals and use a pad to protect the product during your assembly.

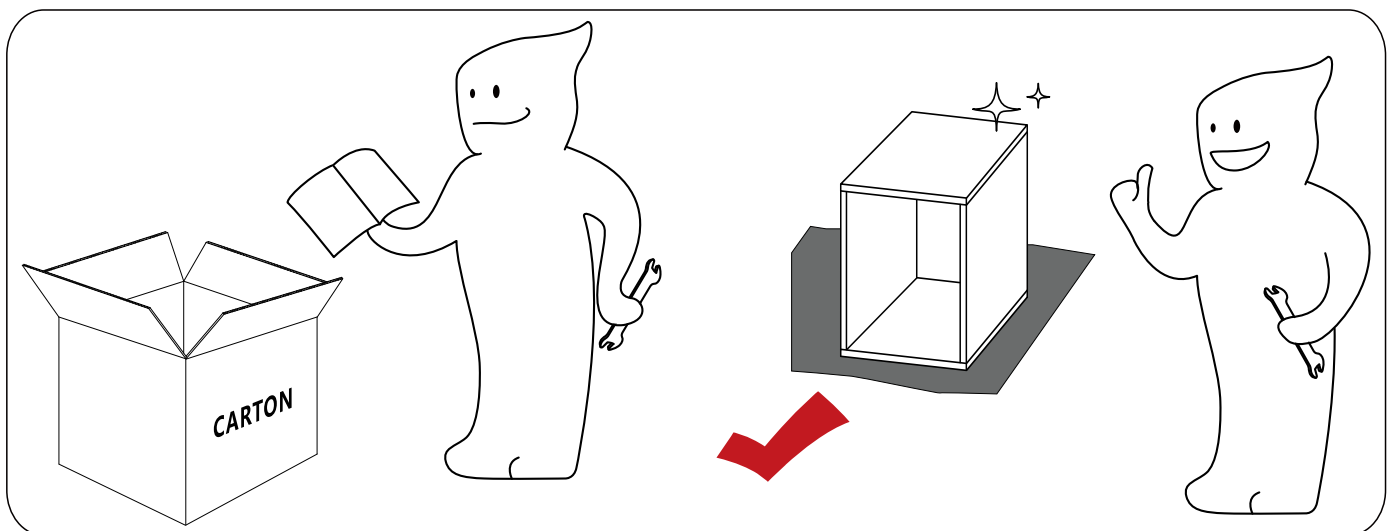
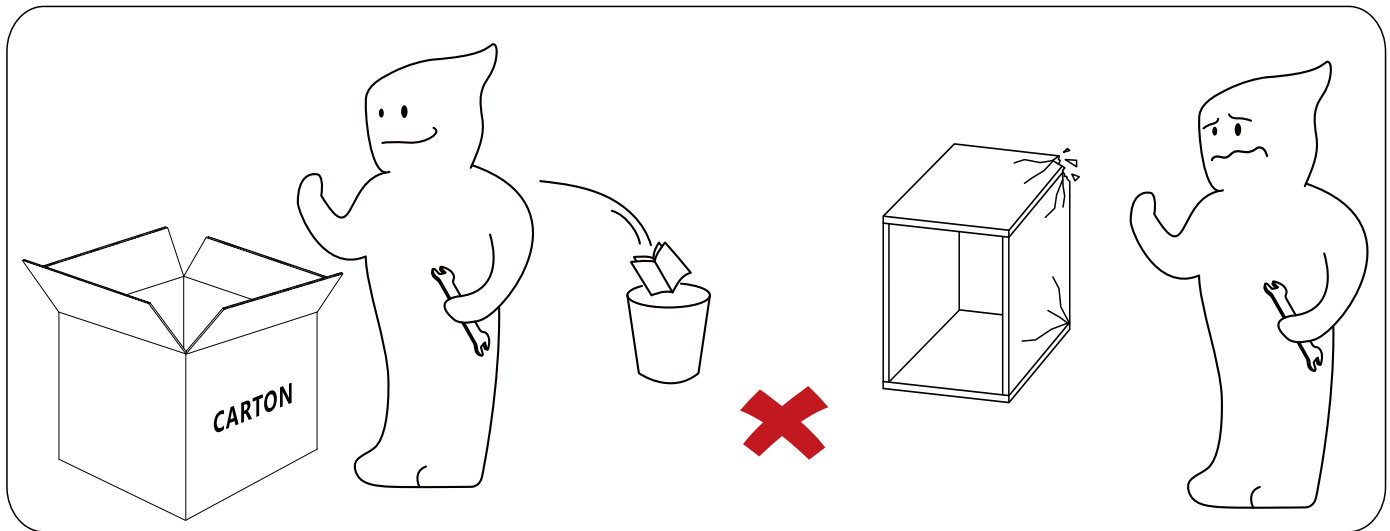













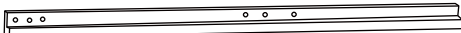
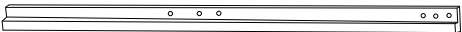

Note:

1. Should be assembled on flat ground to keep balance.
2. Before completing the installation, do not tighten the screws.
3. **Finally, tighten all the screws manually.**

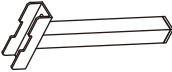

For easier and better assembly, **2** or more adults are required.

ASSEMBLY INSTRUCTIONS

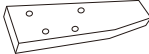
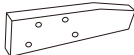
ALPHABETICAL NUMBERING	DESCRIBE	ILLUSTRATION	NUMBER
A	Slat		1pc
B	Slat		1pc
C	Up headboard		1pc
C1	Down headboard		1pc
C2	Down headboard		1pc
D	Headboard leg		1pc
D1	Headboard leg		1pc
E	Footboard		1pc
F	Side panel		2pcs
F1	Side panel		2pcs
G	Support bar		1pc
H	Support bar		1pc
I	Support bar		1pc
J	Support wood		4pcs
K	Support leg		2pcs
L	Support leg		2pcs
M	Wood leg		1pc
M1	Wood leg		1pc

ASSEMBLY INSTRUCTIONS

Ruler-Use this ruler to help correctly identify the screws.

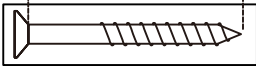

The length of the screw is measured from the rod part excluding the screw cap (30mm screw shown).

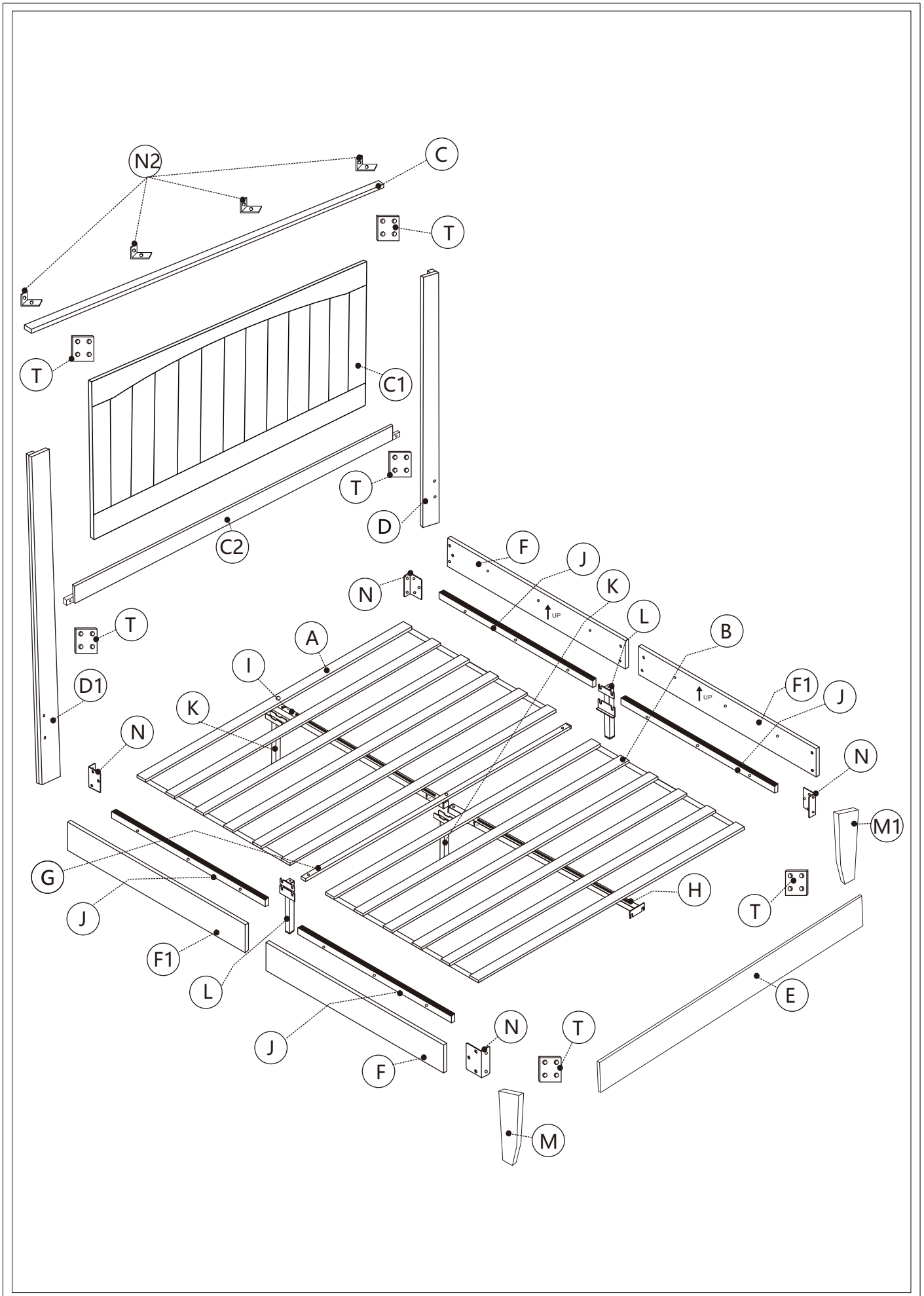

ALPHABETICAL NUMBERING	DESCRIBE	ILLUSTRATION	NUMBER
N	Connector plate 100x2 mm		4pcs
T	Connector plate 70x2 mm		6pcs
N2	Connector plate 35x2 mm		4pcs
O	Sponge-cushion		4pcs
P	Washer φ8x18x1.5 mm		48pcs+1pc
P1	Washer φ6x18x1.5 mm		30pcs+1pc
Q	Wrench M6		1pc
R	Screw M8x50 mm		1pc
R1	Screw M8x35 mm		5pcs
R2	Screw M8x30 mm		12pcs
R3	Screw M8x25 mm		8pcs
R4	Screw M8x16 mm		22pcs+1pc
R5	Screw M6x75 mm		2pcs
R6	Screw M6x30 mm		2pcs
R7	Screw M6x16 mm		32pcs+1pc

ASSEMBLY INSTRUCTIONS

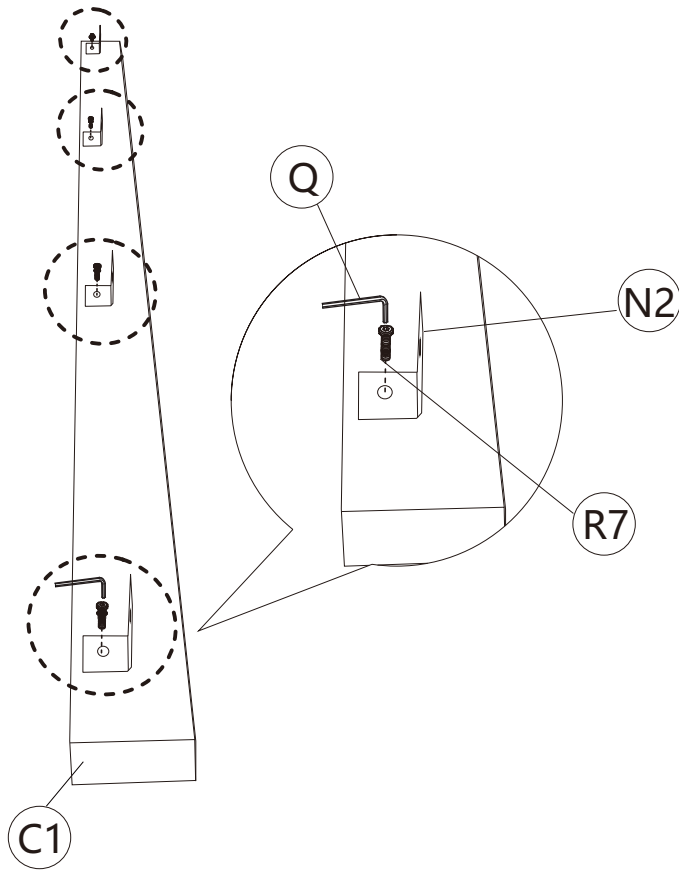

1





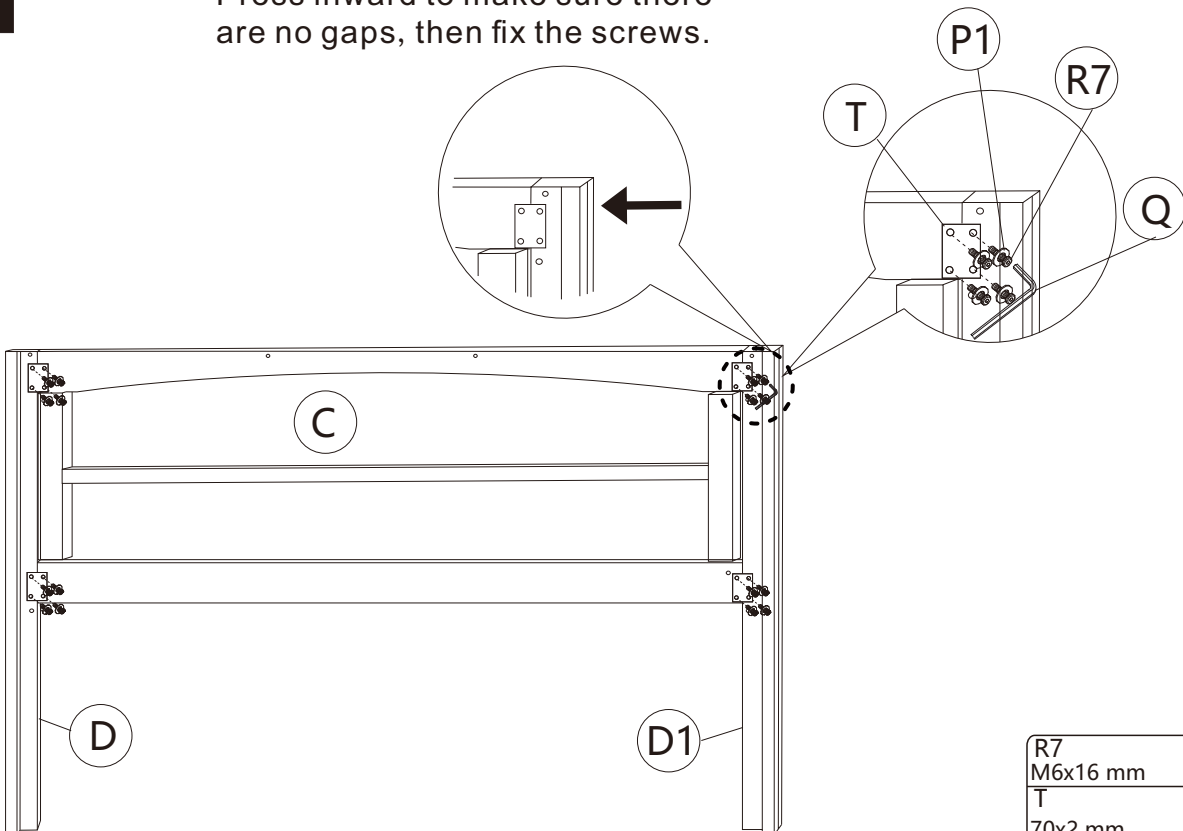

R7		4 pcs
M6x16 mm		
N2		4 pcs
35x2 mm		
Q		1 pc
M6		

2

Press inward to make sure there are no gaps, then fix the screws.





R7		16 pcs
M6x16 mm		
T		4 pcs
70x2 mm		
P1		16 pcs
φ6x18x1.5 mm		
Q		1 pc
M6		

ASSEMBLY INSTRUCTIONS

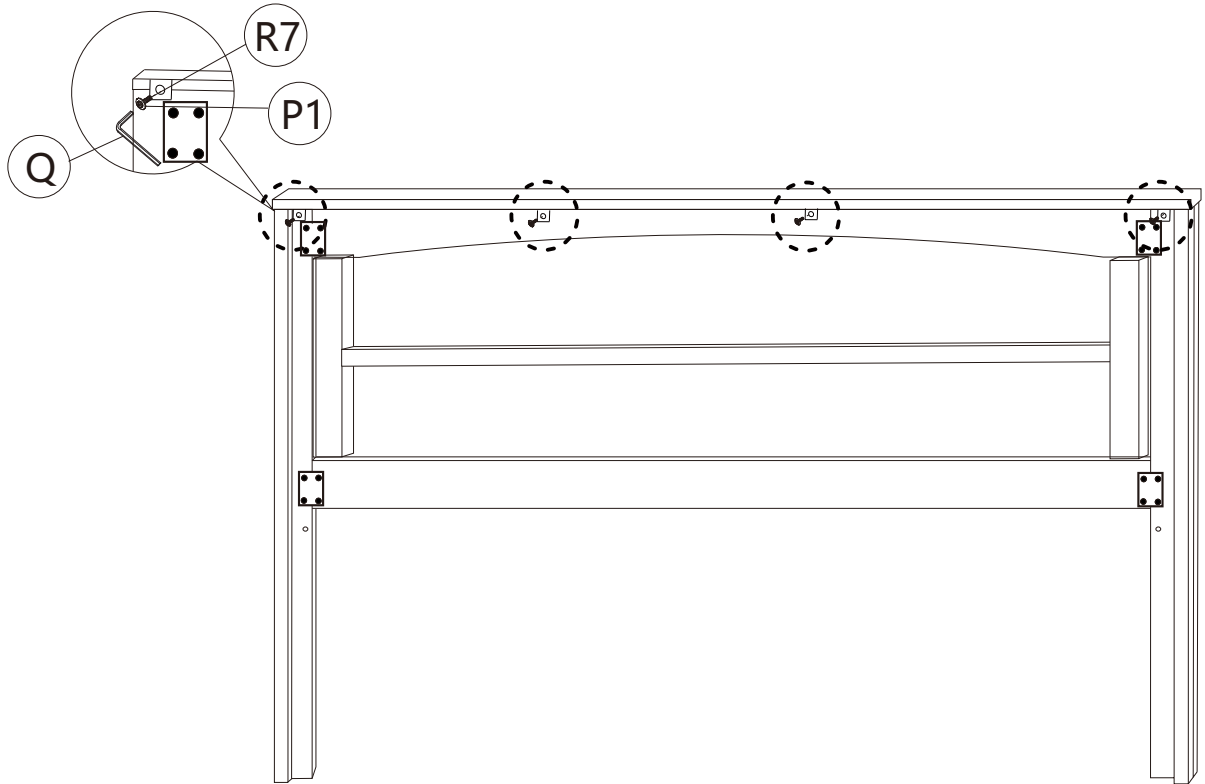

3



R7	M6x16 mm		4pcs
P1	φ6x18x1.5 mm		4pcs
Q	M6		1pc

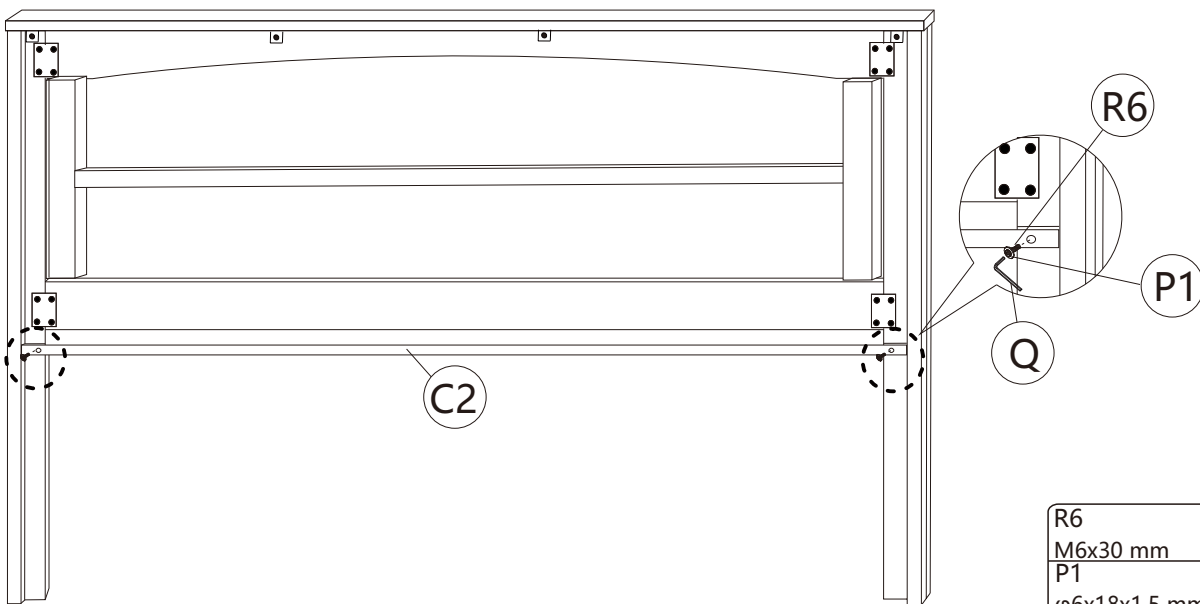

4

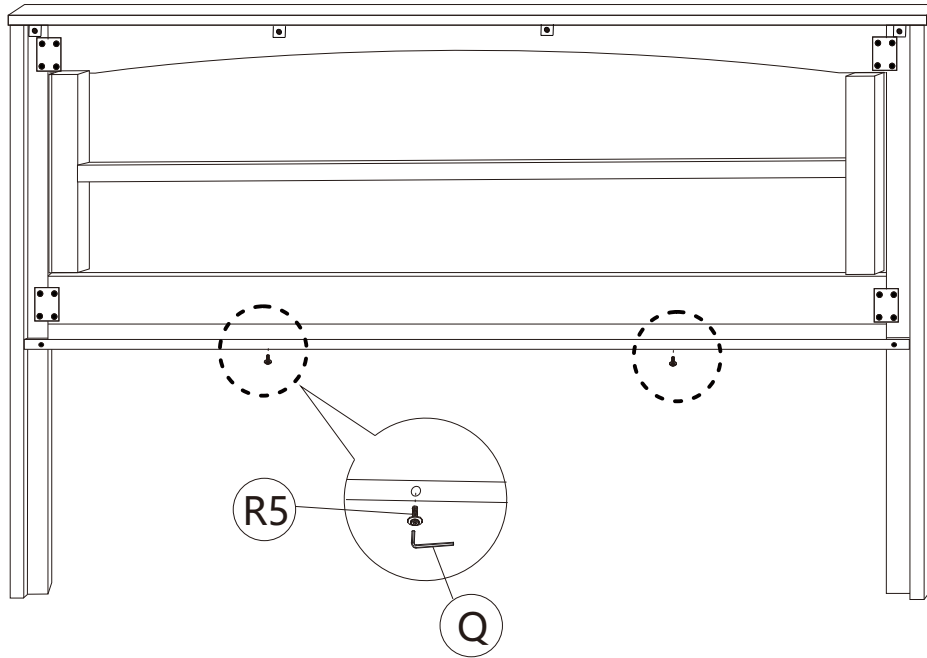

R6	M6x30 mm		2pcs
P1	φ6x18x1.5 mm		2pcs
Q	M6		1pc

5





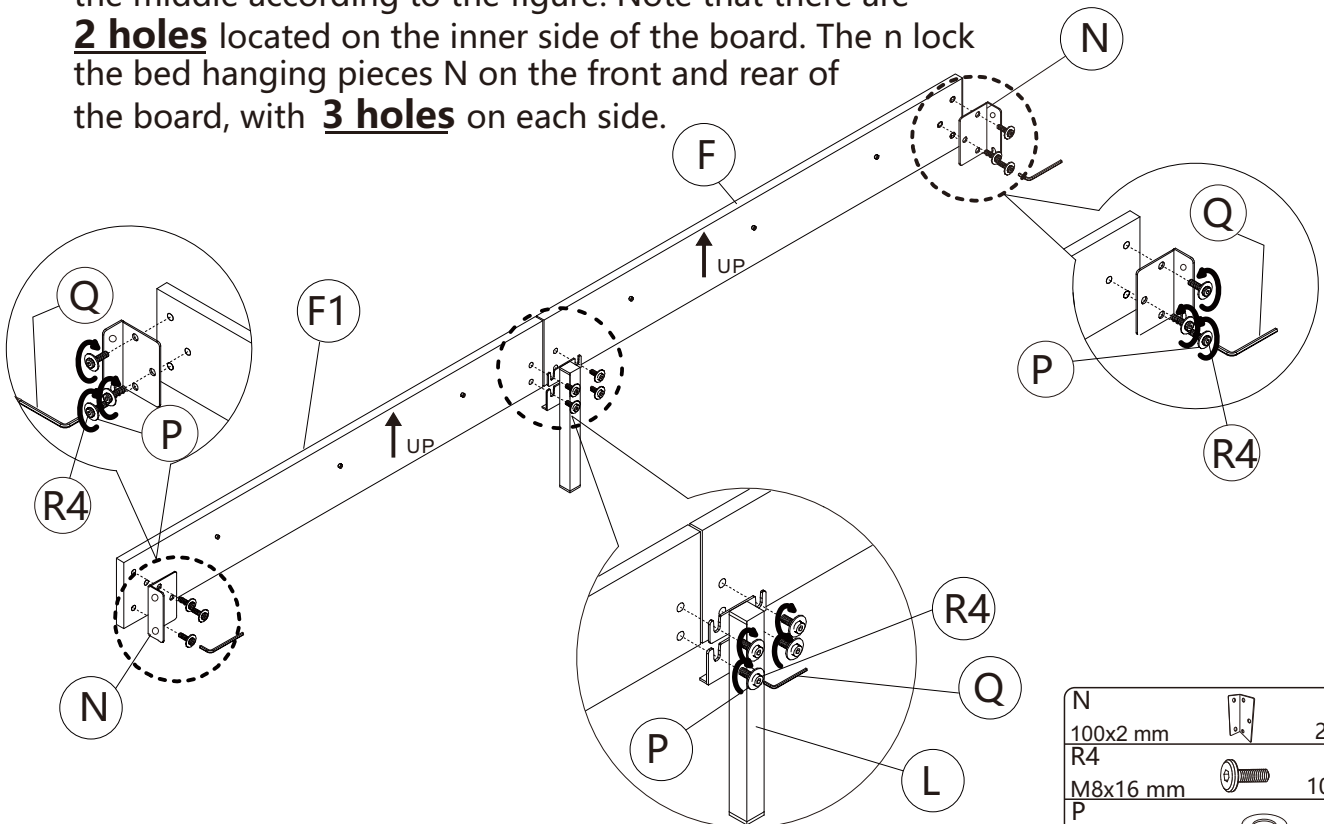

R5		2pcs
M6x75 mm		
Q		1pc
M6		

6

Take out parts F1 and F, and lock the iron frame foot L in the middle according to the figure. Note that there are **2 holes** located on the inner side of the board. The n lock the bed hanging pieces N on the front and rear of the board, with **3 holes** on each side.



N		2pcs
100x2 mm		
R4		10pcs
M8x16 mm		
P		10pcs
φ8x18x1.5 mm		
Q		1pc
M6		

7 Same as Step 6

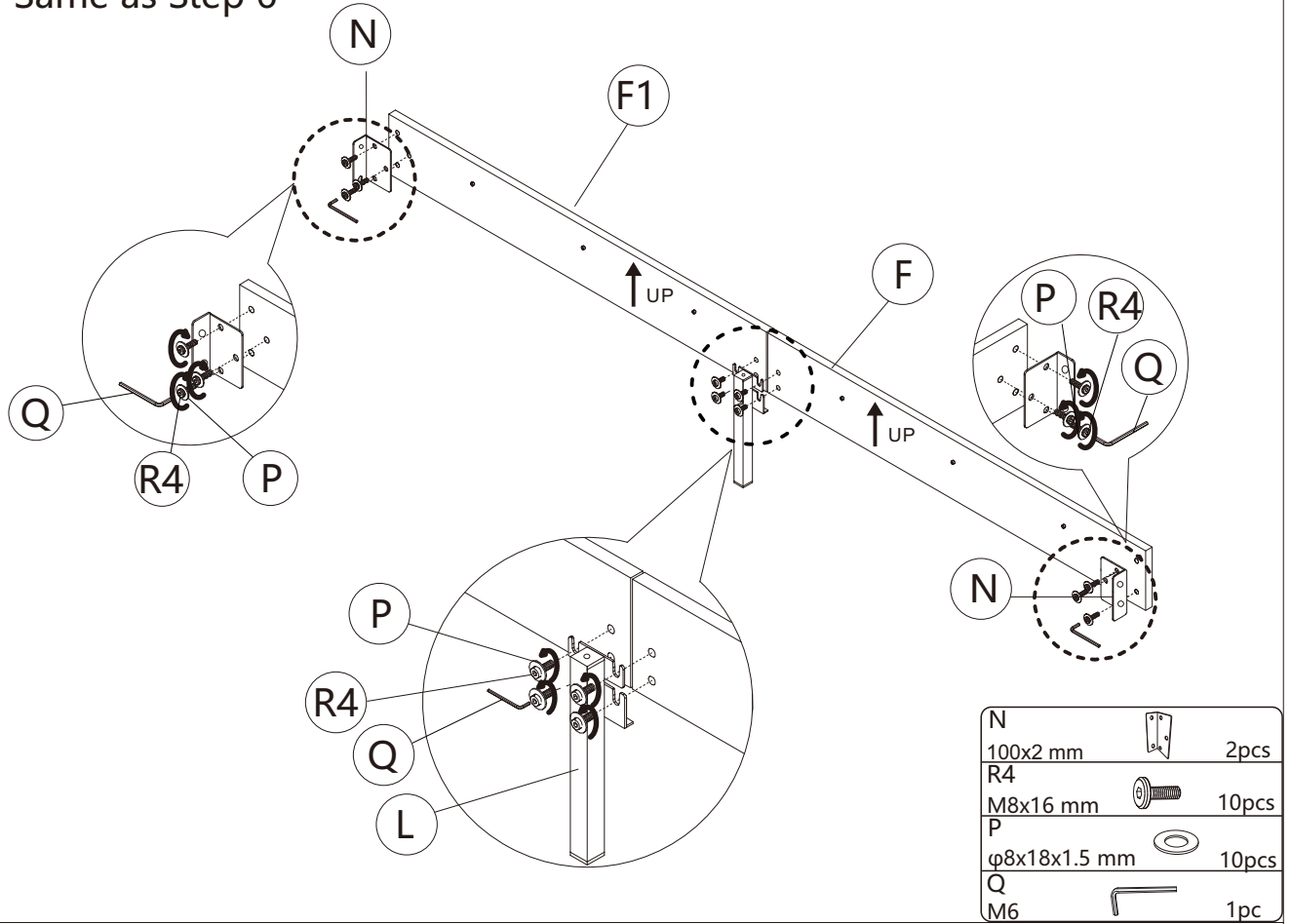



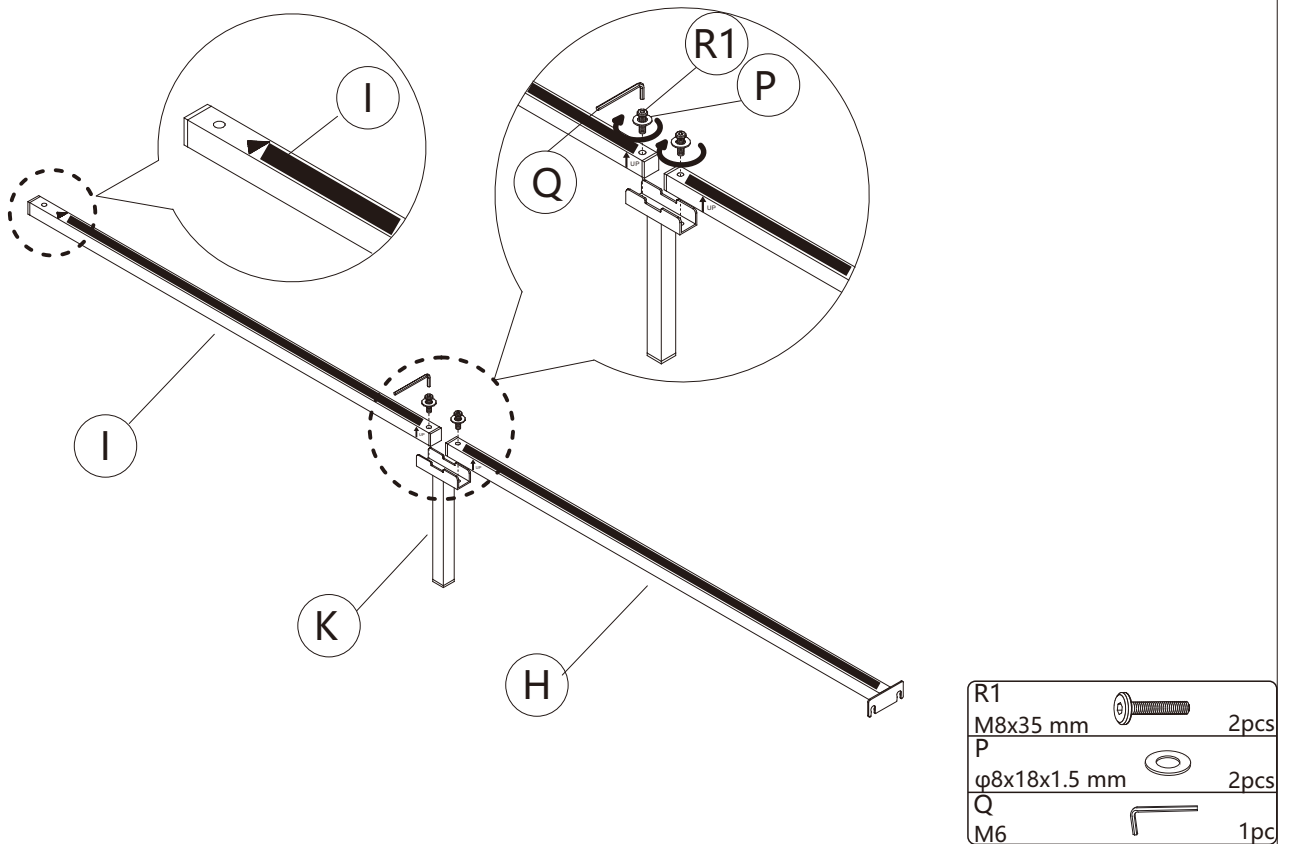

8 Noted the direction of the arrow on the middle cross beam is pointing to the front.

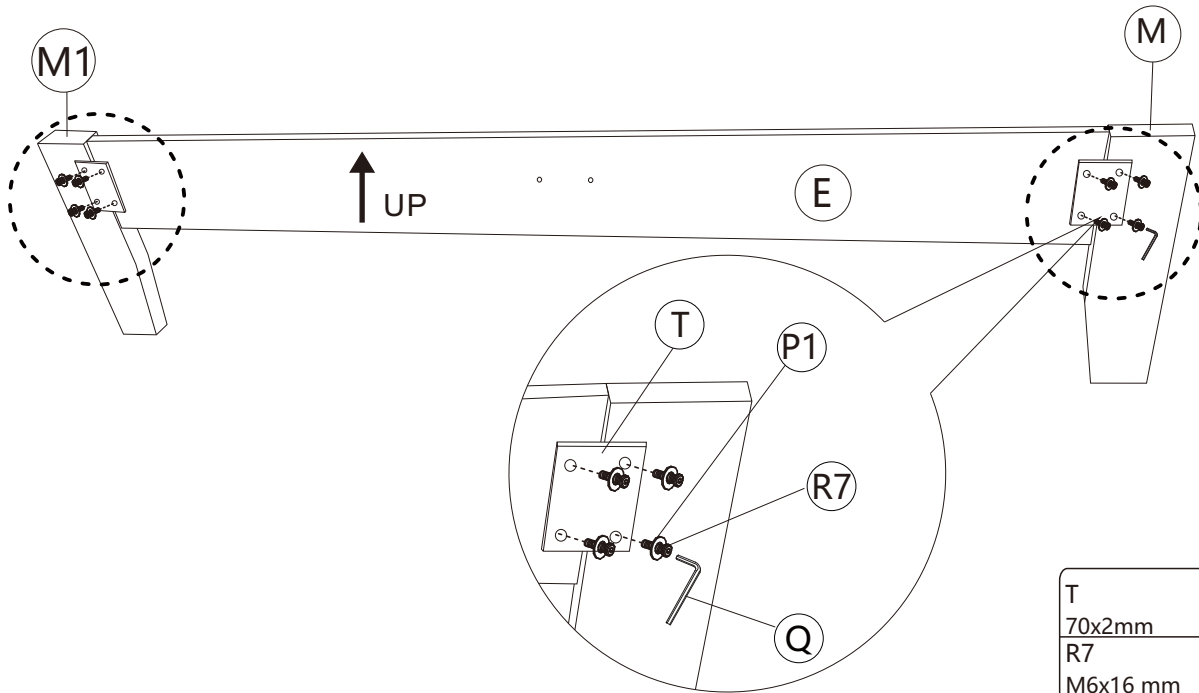





9

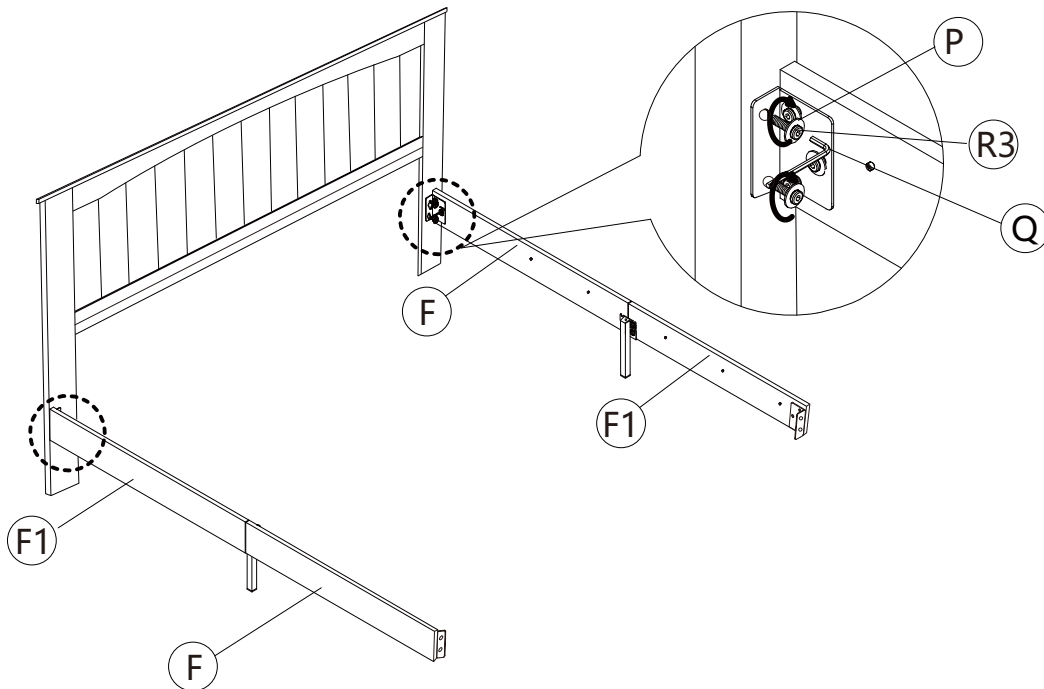

T		2pcs
R7		8pcs
P1		8pcs
Q		1pc

10





R3		4pcs
P		4pcs
Q		1pc

ASSEMBLY INSTRUCTIONS

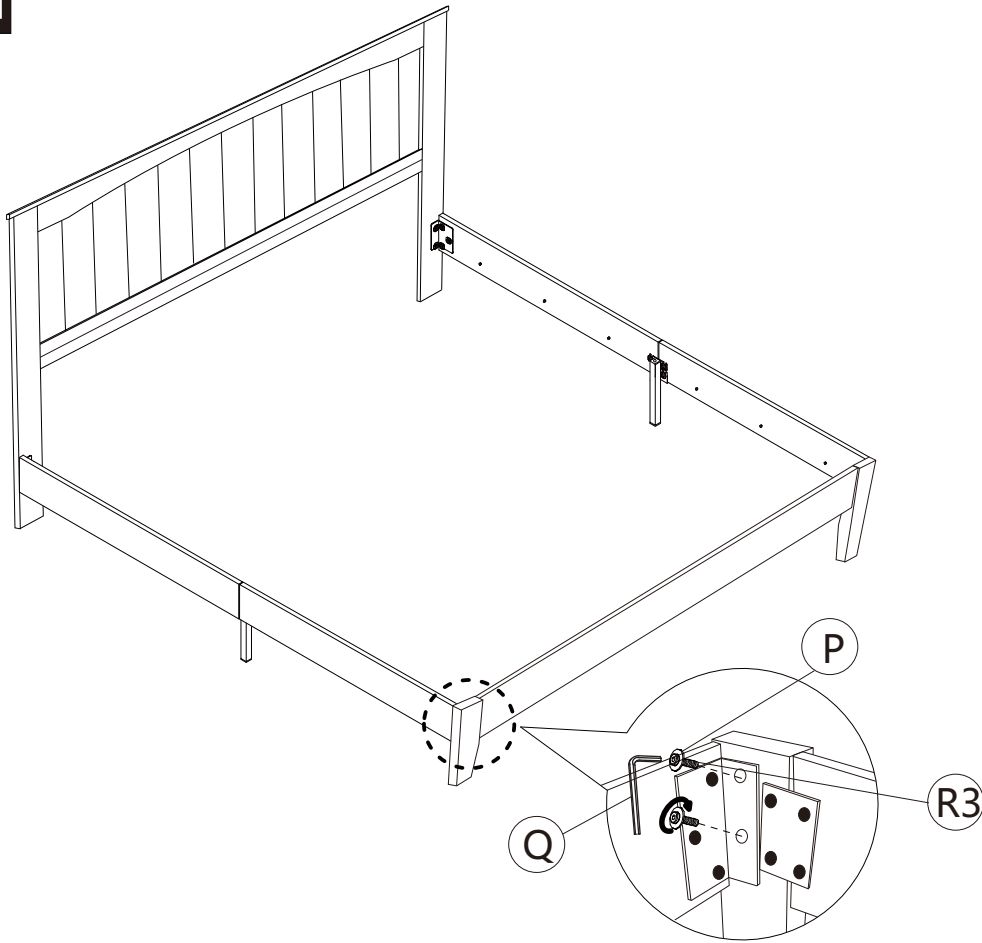

11



R3		4pcs
M8x25 mm		
P		4pcs
φ8x18x1.5 mm		
Q		1pc
M6		

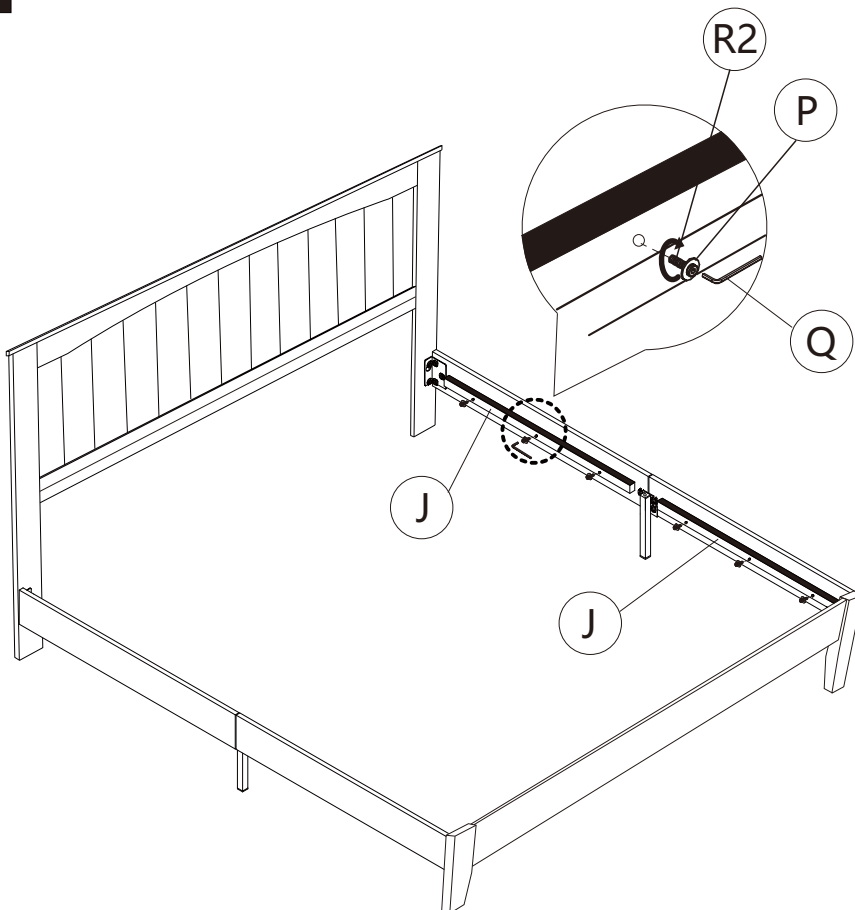

12



R2		12pcs
M8x30 mm		
P		12pcs
φ8x18x1.5 mm		
Q		1pc
M6		

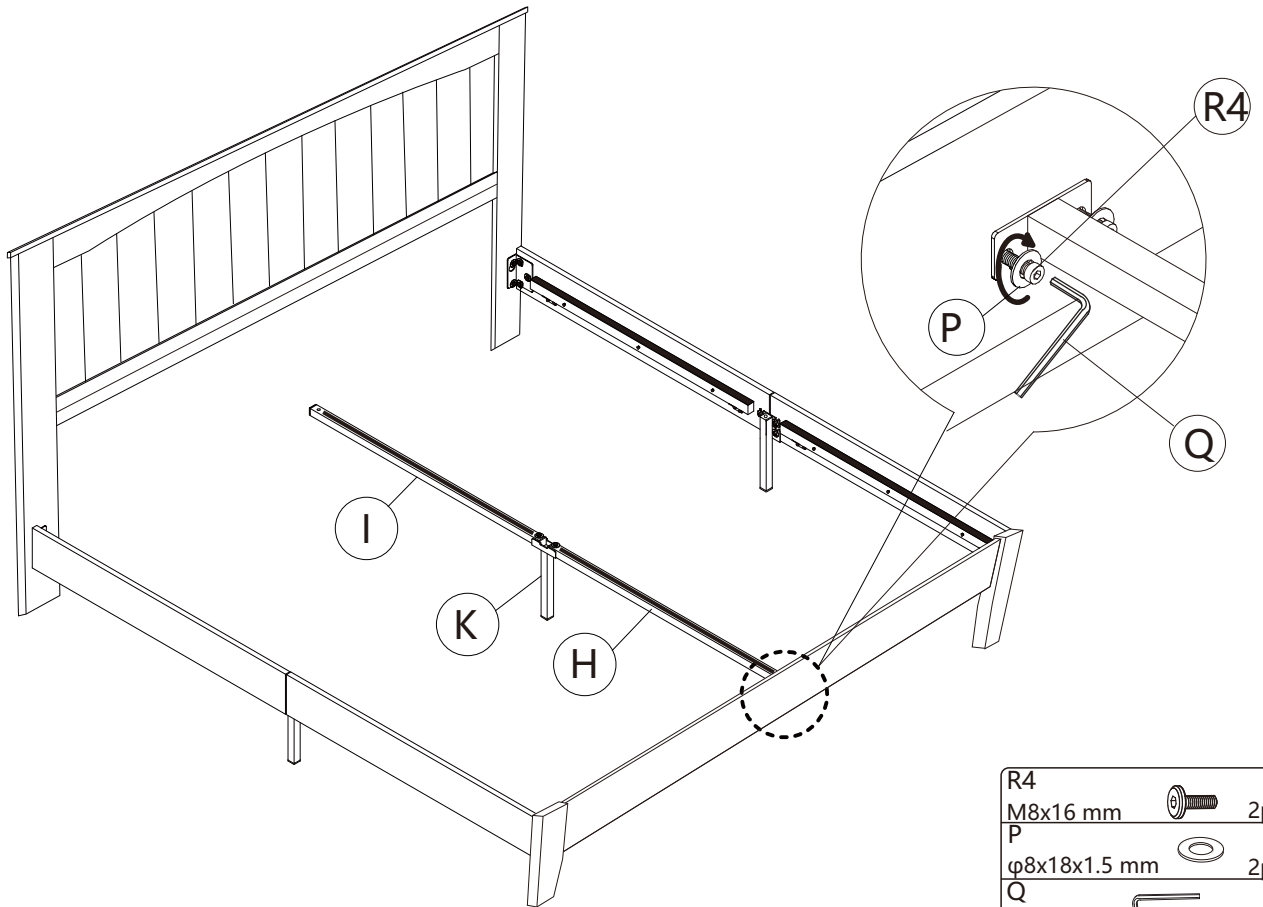

13

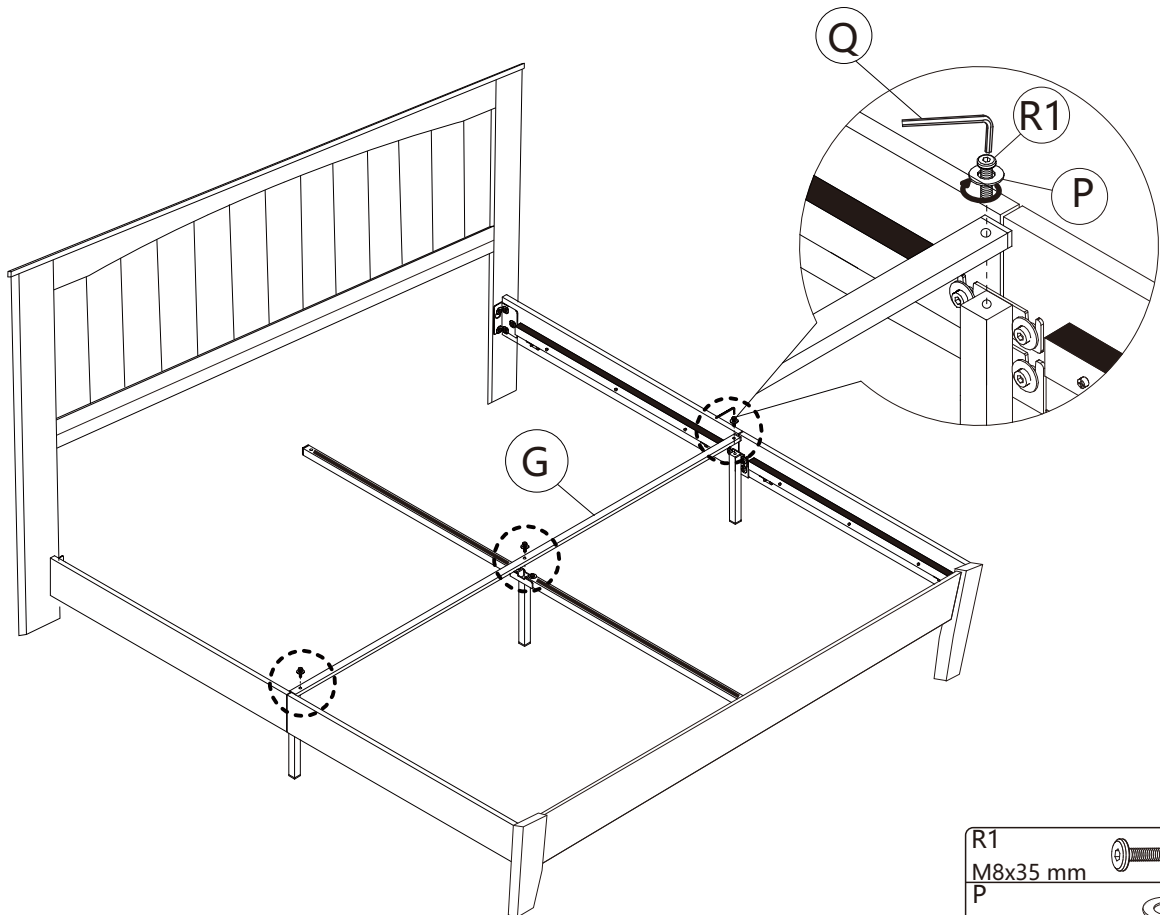

R4		2 pcs
M8x16 mm		
P		2 pcs
φ8x18x1.5 mm		
Q		1 pc
M6		

14



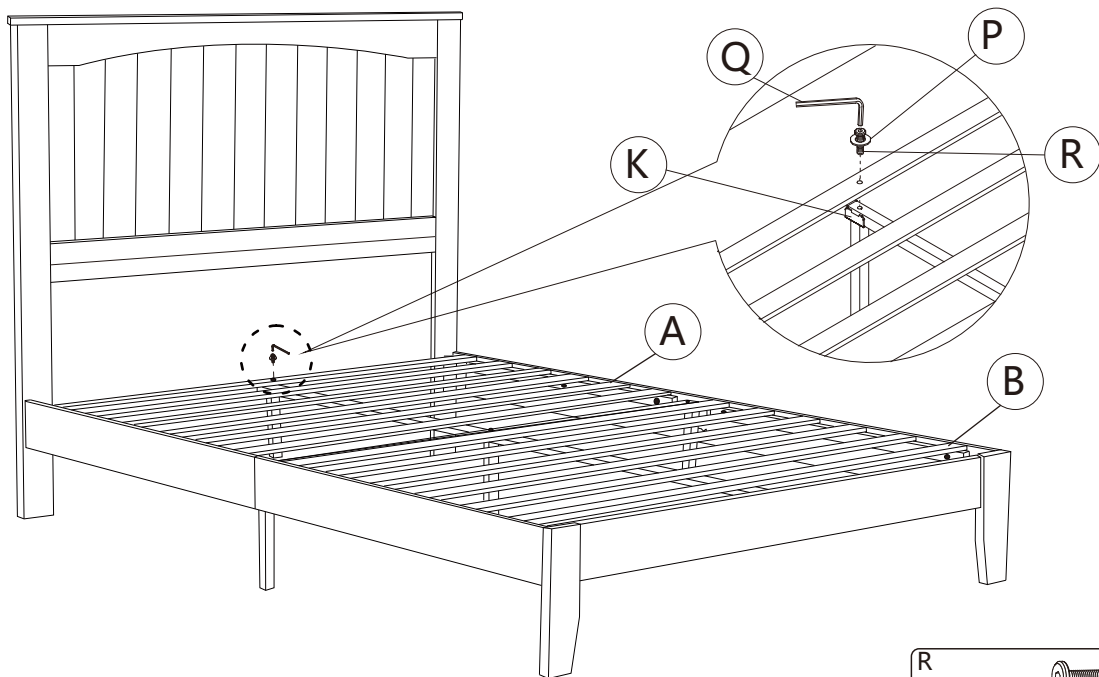

R1		3 pcs
M8x35 mm		
P		3 pcs
φ8x18x1.5 mm		
Q		1 pc
M6		

15 Note that there is a slat with a hole in part A for connecting to part K.



Pls make sure that all screws are 100% tight.

R	M8x50 mm		1pc
P	φ8x18x1.5 mm		1pc
Q	M6		1pc

16 Stick **O** on the back to avoid noise.

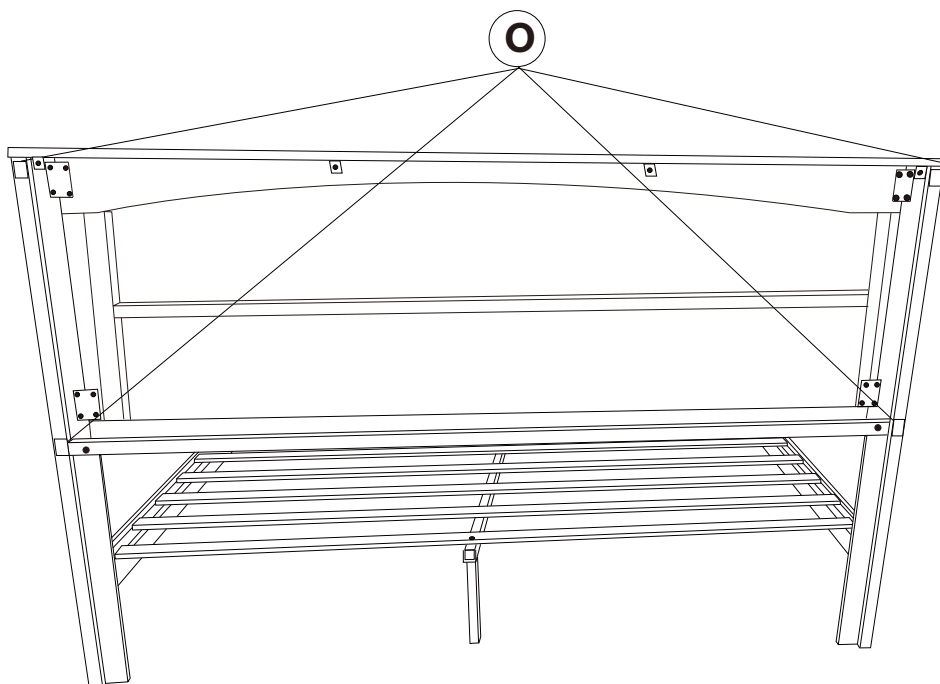

17



Installation Complete