

Assembly Instructions

Caution: You must read this **Assembly Instructions** before you proceed.

Please look in the **Leg Frames** for all hardware.

TABLE

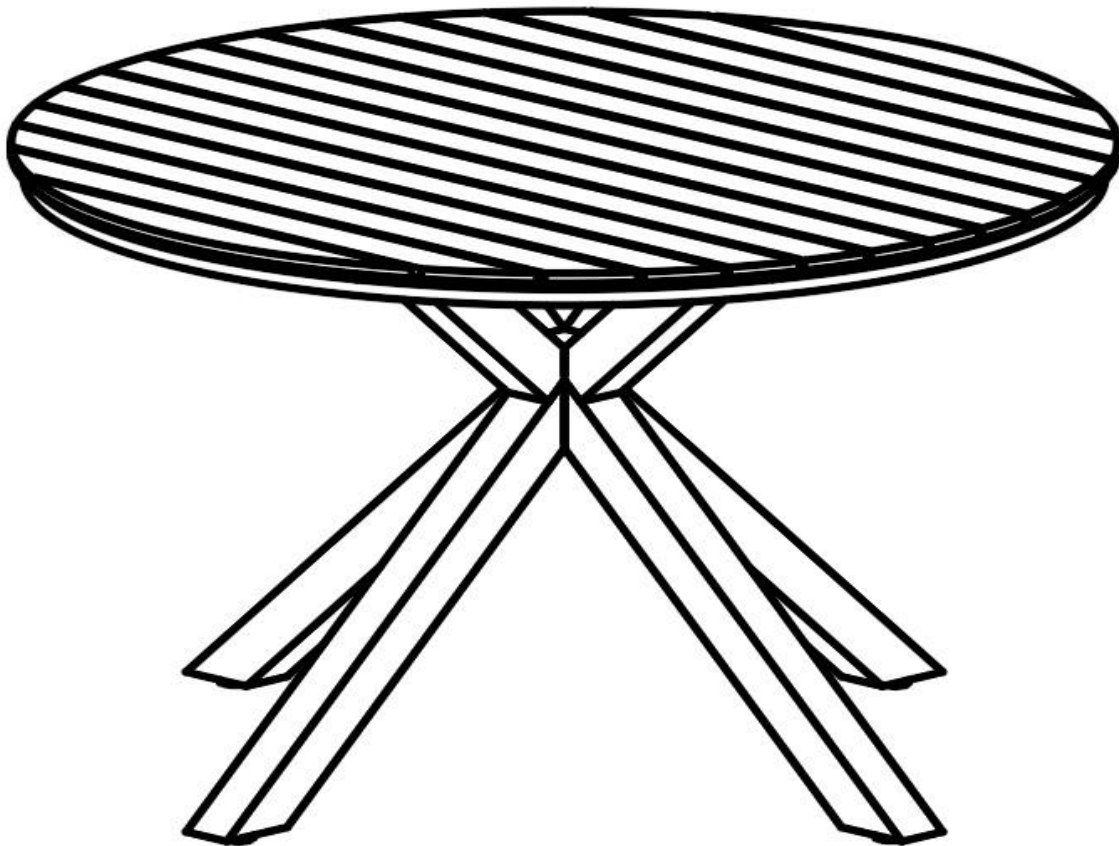

CAUTION: This Table is NOT a TOY.



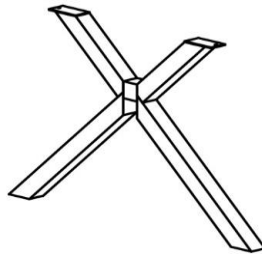
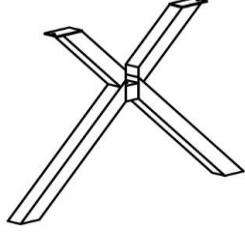

Keep your child / children at bay during the assembly process.

Whenever lifting or moving the Table and to prevent damage to the Table, two adult partners may be needed to execute these actions.

Part List:

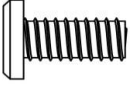
Label	Picture	Description	QTY
A	 A perspective drawing of an oval-shaped table top with a wood-grain texture.	Table Top	1
B	 A perspective drawing of a four-legged frame structure, consisting of four legs meeting at a central point.	First Leg Frame	1
C	 A perspective drawing of a second four-legged frame structure, identical to the first one.	Second Leg Frame	1

Hardware:

Label	Picture	Description	QTY
①	 A perspective drawing of a short bolt with a hexagonal head.	Bolt (M6x20mm)	5
②	 A perspective drawing of a long bolt with a hexagonal head.	Bolt (M6x75mm)	2
③	 A perspective drawing of an L-shaped Allen wrench.	Allen Wrench	2
④	 A perspective drawing of a flat washer with a central hole.	Washer (M6.5/20x2mm)	6

Assembly Preparation

Before Beginning Assembly:

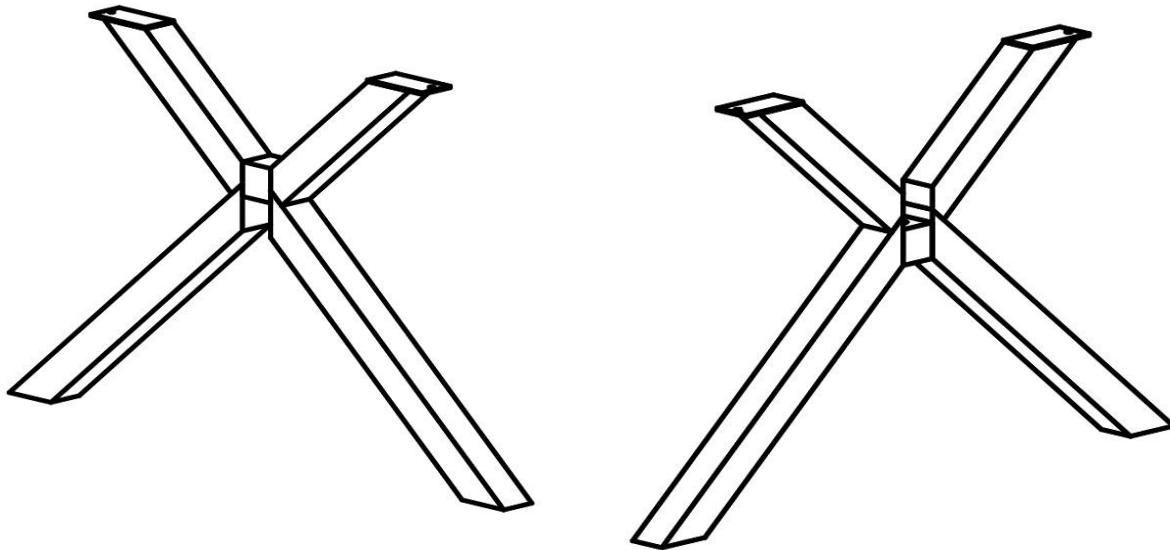
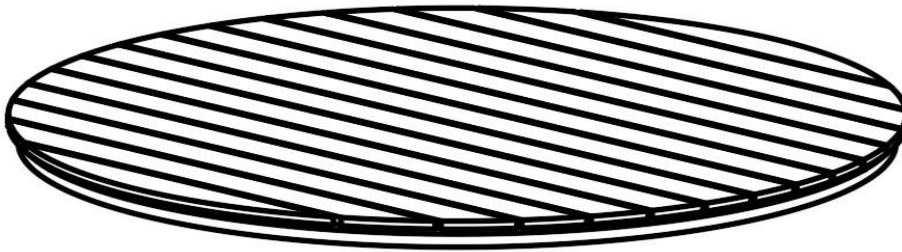
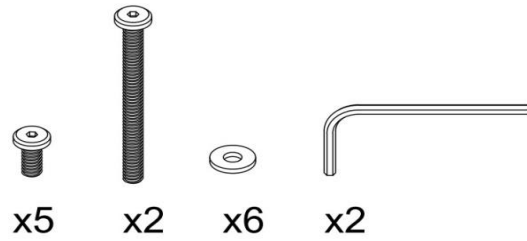

- Read instructions, cover to cover-



- Have 2 adults on hand for assembly-



- Do not assemble on flooring or carpet-



- Assemble on a clean non-marring surface (packing foam)-



- Save all packaging until finished-

Assembly Steps:

Overview

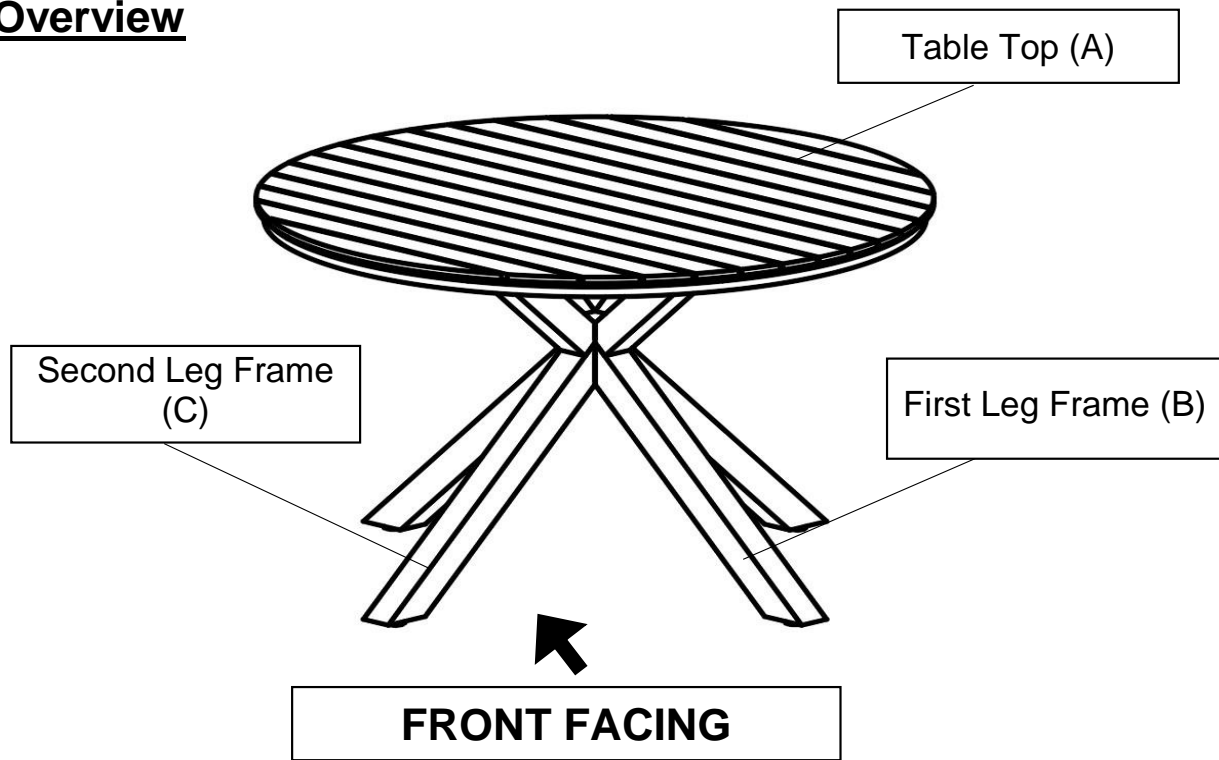

This Table has multiple parts and may require up to 30 minutes to assemble. To give you an overview of the Table parts, the above picture is to help you put the various parts into perspective. Please read through the instructions below to familiarise yourself with the parts and steps before assembly.

Step 1

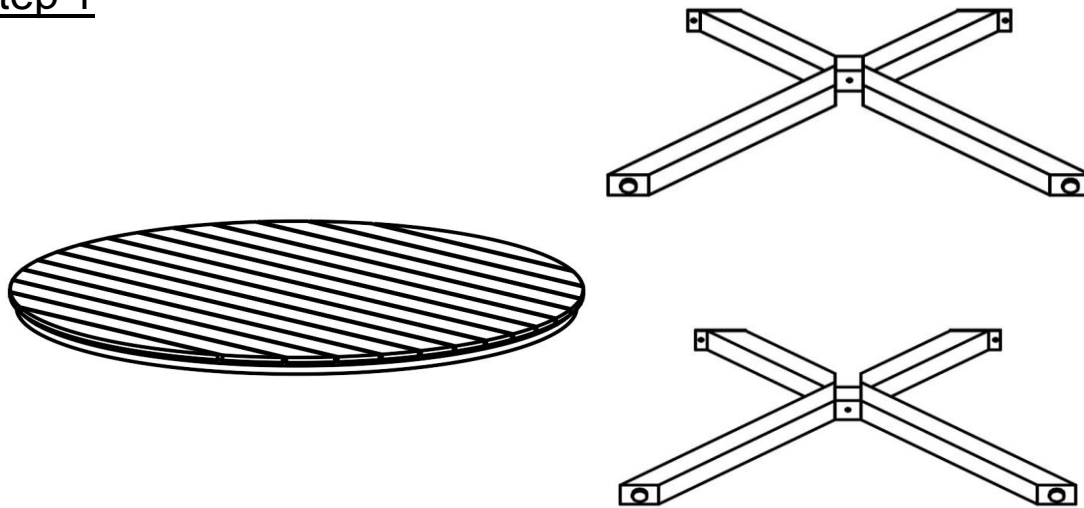

Unpack and place all parts on a clean, non-marring surface.

Step 2

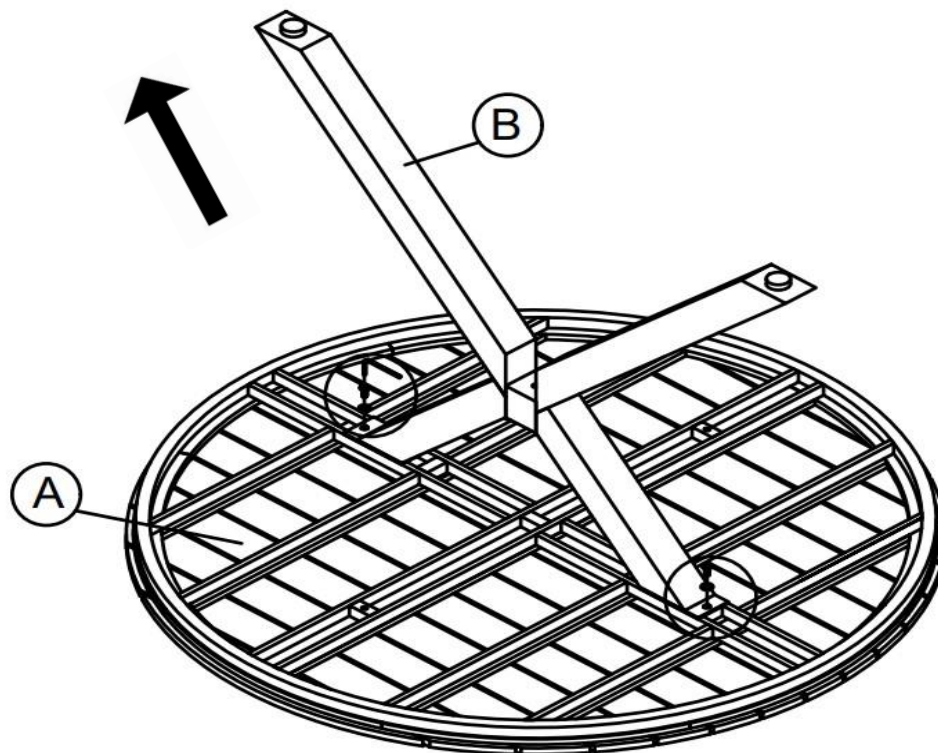
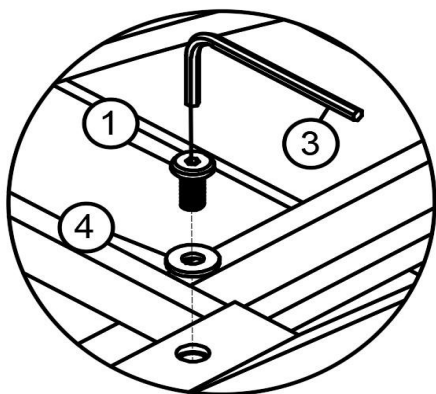

With assistance from your adult partners, turn the Table Top (A) (bottom-side up) and place on a clean, non-marring surface to avoid any scratches or damage to the product.

Attach the First Leg Panel (B) to the Table Top(A) using Bolts (1), Washers (4) and the Allen Wrench(3)

DO NOT fully tighten the Bolts at this time.

Step 3

Step 3.1

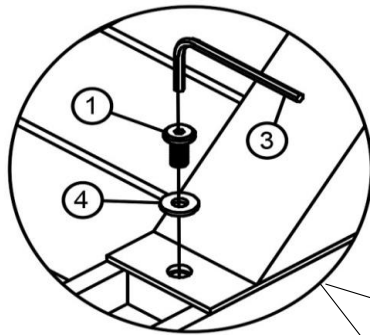
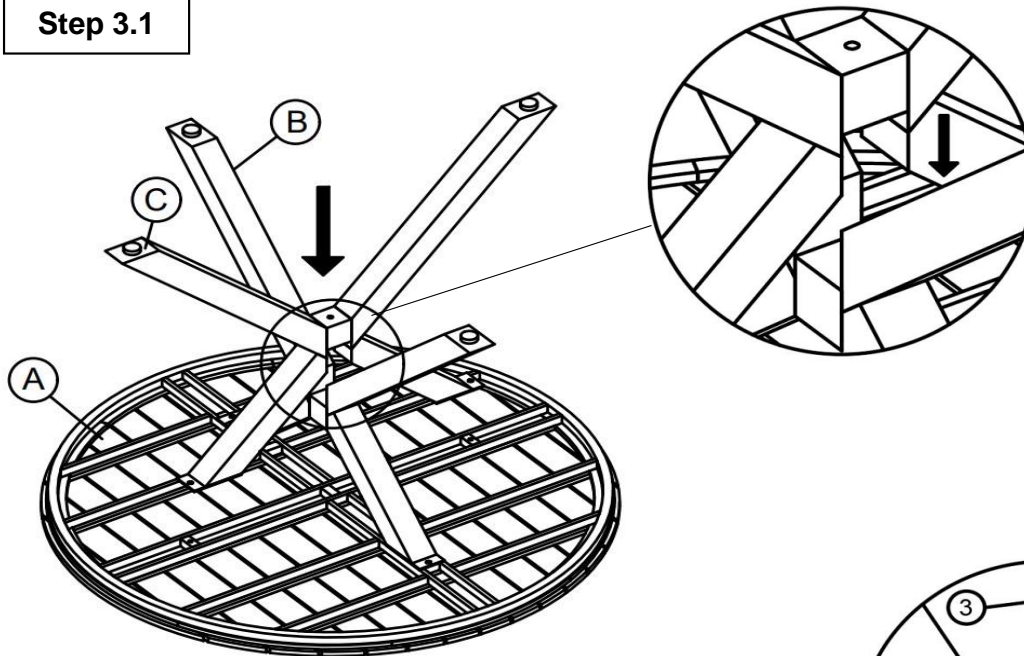

Step 3.2

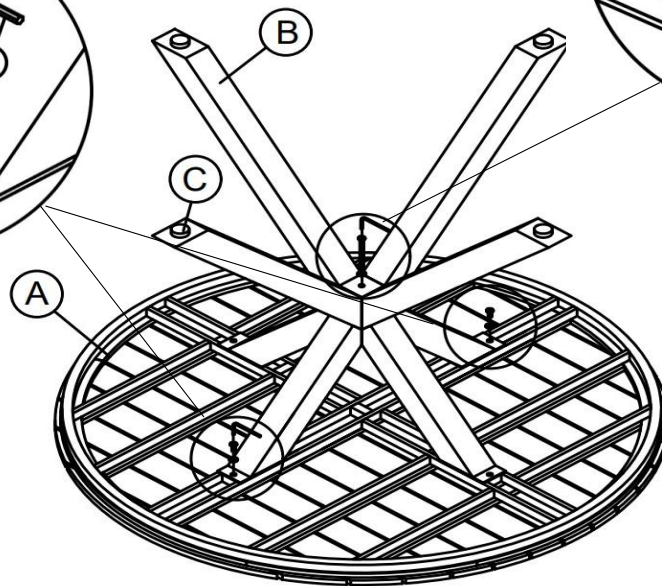

Step 3.3

3.1) Position the Second Leg Panel (C) to the First Leg Panel (B) and the Table Top (A) as shown in the above picture.

3.2) Attach the Second Leg Panel (C) to the Table Top (A) using Bolts (①), Washers (④) and the Allen Wrench(③)

3.3) Secure the Second Leg Panel (C) to the First Leg Panel (B) using a Bolt (②), Washer (④) and the Allen Wrench(③).

In this step, the legs with levelers will be upside down.

DO NOT fully tighten the Bolts at this time.



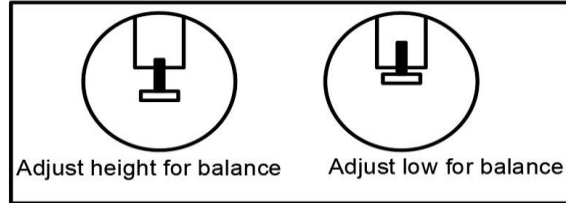
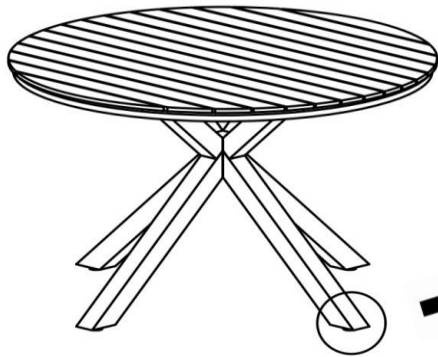







Step 4



Adjust Pre - installed levelers
height for balance

With the assistance from your adult partners, stand the Table up. EXERT pressure floorwards onto the Table with both hands. This pressure will help the Table reach full alignment at all joints. In a sequential manner, gradually tighten all Bolts at all joints until evenly secured. Inspect the Table and make sure all parts are adequately connected. **Adjust the Levelers to the desired height to avoid wobbles.** Your Table is ready for use. **This Table can only be used on a flat, level surface.**

Care & Maintenance

- ⊘  • Prolonged exposure to rain may cause rusting which can stain floors.
- ⊘  • Do not put hot items directly on furniture surface.
- ⊘  • Do not clean furniture with harsh cleansers or polish.
- ✓  • To obtain the longest lifespan of your outdoor products, minimizing exposure to direct sunlight is recommended.
- ⊘  • Children should not climb or jump on the furniture.
- ⊘  • Do not write on furniture without a padded barrier to protect the surface.
- ✓  • To obtain the longest lifespan of your outdoor products, avoid extended and lengthy exposure to rain, snow, and direct sunshine. Whenever possible cover the product and /or place under patio or awnings.
- ⊘  • Not for commercial use. For residential use only.
- ⊘  • Stains may be removed with mild soap solution and damp cloth.
- ✓  • Dust and pick-up spills using a clean, non-colored, lint-free cloth.