

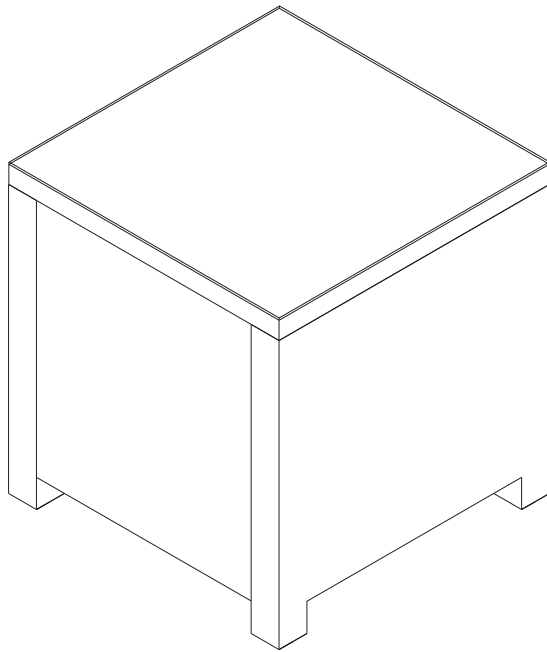

# End Table

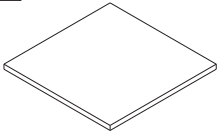

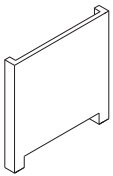
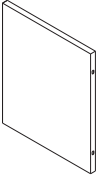
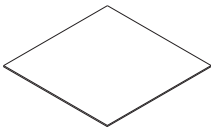

## PART LIST

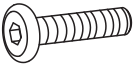
<b>A</b> 	<b>B</b> 	<b>C</b> 	<b>D</b> 
Wicker Top 1PC	Side Panel 2PCS	End Panel 2PCS	Glass Top 1PC

## HARDWARE LIST

<b>#1</b> 	<b>#2</b> 	<b>#3</b> 
M6*40mm Bolt 12PCS	M6mm Washer 12PCS	M6mm Allen Key 1PC

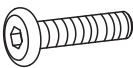

## EXTRA HARDWARE LIST

<b>#1</b> 	<b>#2</b> 
M6*40mm Bolt 3PCS	M6mm Washer 3PCS

Step 1. Lay wicker top (part #A) on a flat surface with underside facing up. Attach one side panel (part #B) to the wicker top (part #A) using bolts (part #1), washers (part #2) and allen key (part #3). Attach one end panel (part #C) to the assembled parts (part #A & B) using bolts (part #1), washers (part #2) and allen key (part #3).

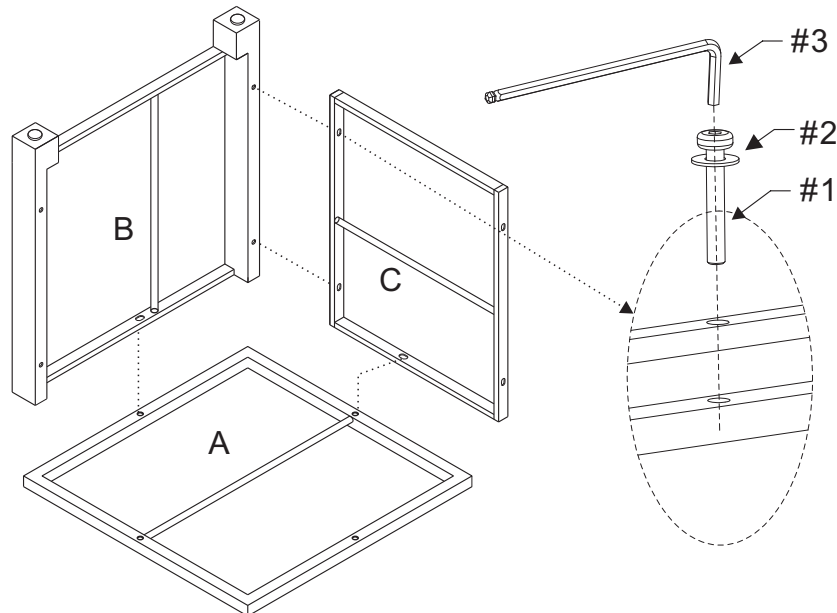
NOTE: Please do not fully tighten bolts until unit is fully assembled.





- |    |   |    |
|----|---|----|
| #1 |    | x4 |
| #2 |    | x4 |
| #3 |  | x1 |

Step 2. Attach remaining end panel (part #C) to the assembled parts (part #A, B & C) using bolts (part #1), washers (part #2) and allen key (part #3). Attach remaining side panel (part #B) to the assembled parts (part #A, B & Cx2) using bolts (part #1), washers (part #2) and allen key (part #3).

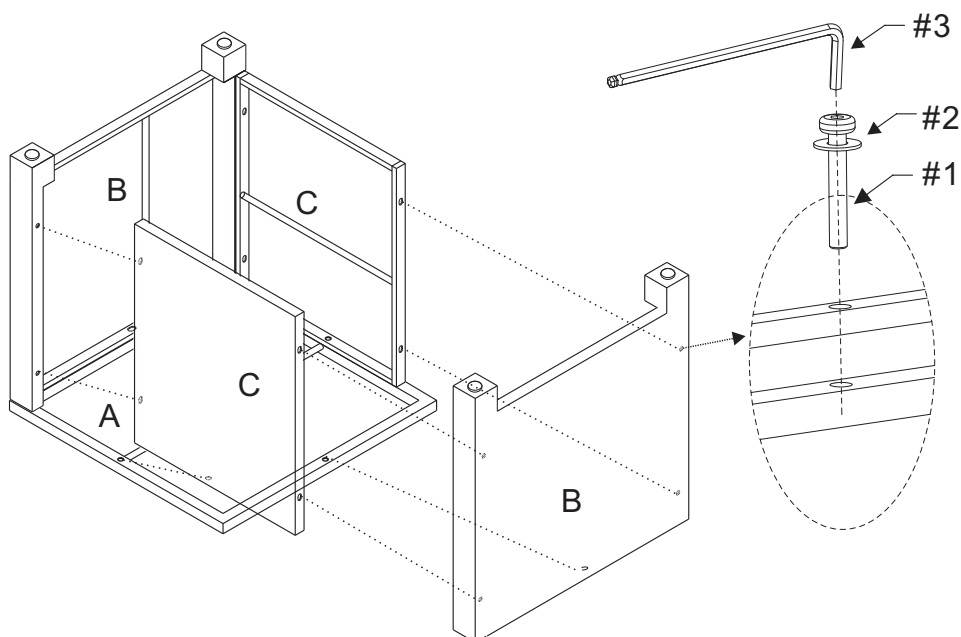
NOTE: Please fully tighten all bolts at this time.



- |    |   |    |
|----|---|----|
| #1 |  | x8 |
| #2 |  | x8 |
| #3 |  | x1 |

Step 3. Carefully turn the table upright and place the glass on the table top.

