

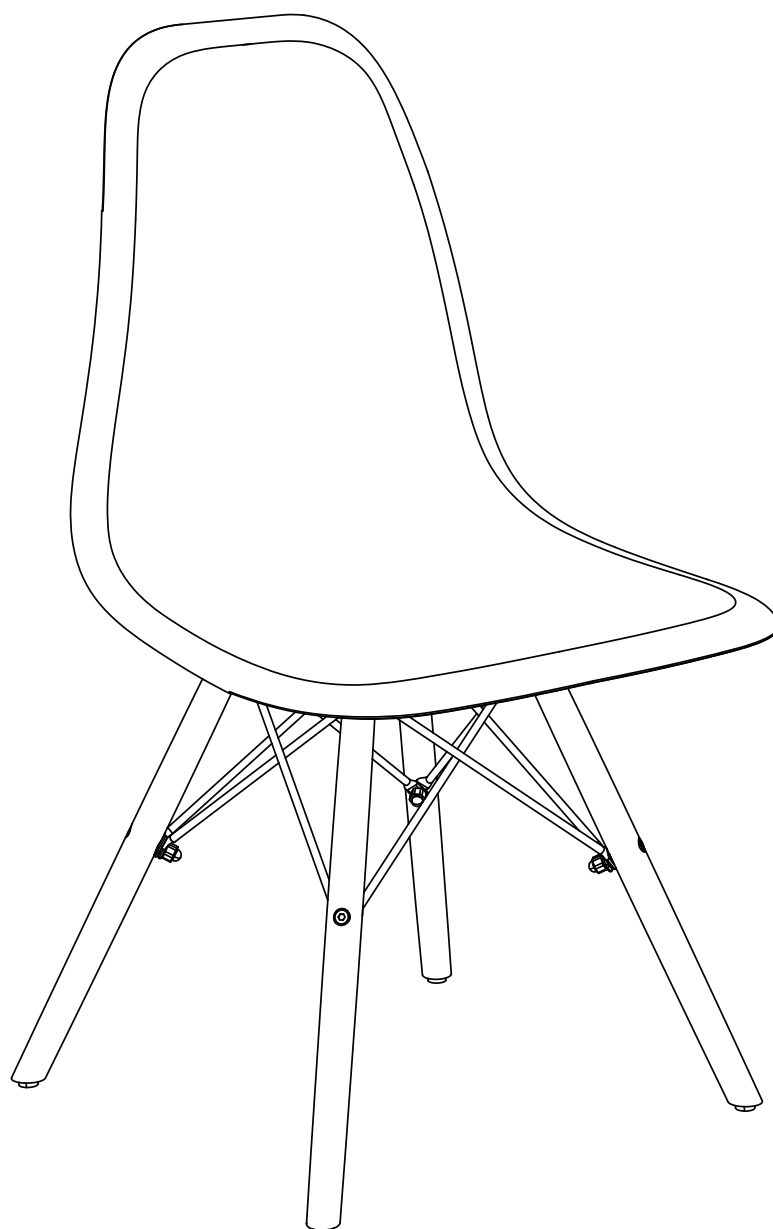







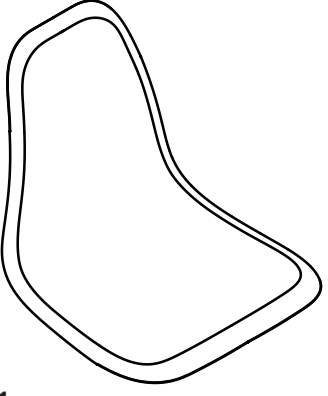
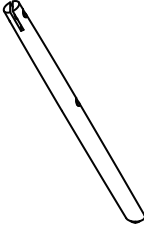
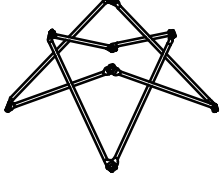

# ASSEMBLY INSTRUCTIONS

---

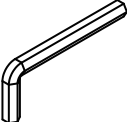
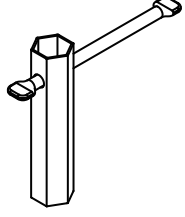

# PARTS

 <p>A X1</p>	 <p>B X1</p>	 <p>C X2</p>
 <p>D X1</p>	 <p>E X4</p>	 <p>F X1</p>
 <p>G X8 6*35mm</p>	 <p>H X4 6*14mm</p>	 <p>I X8</p>
 <p>J X4</p>	 <p>K X8</p>	 <p>L X1</p>
 <p>M X1</p>		

# STEP 1

Please pay attention to the installation direction of the screws.

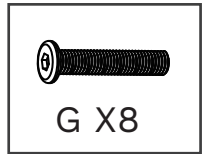
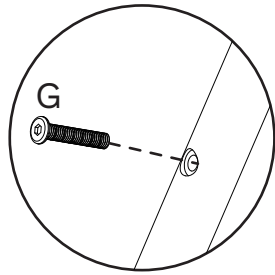
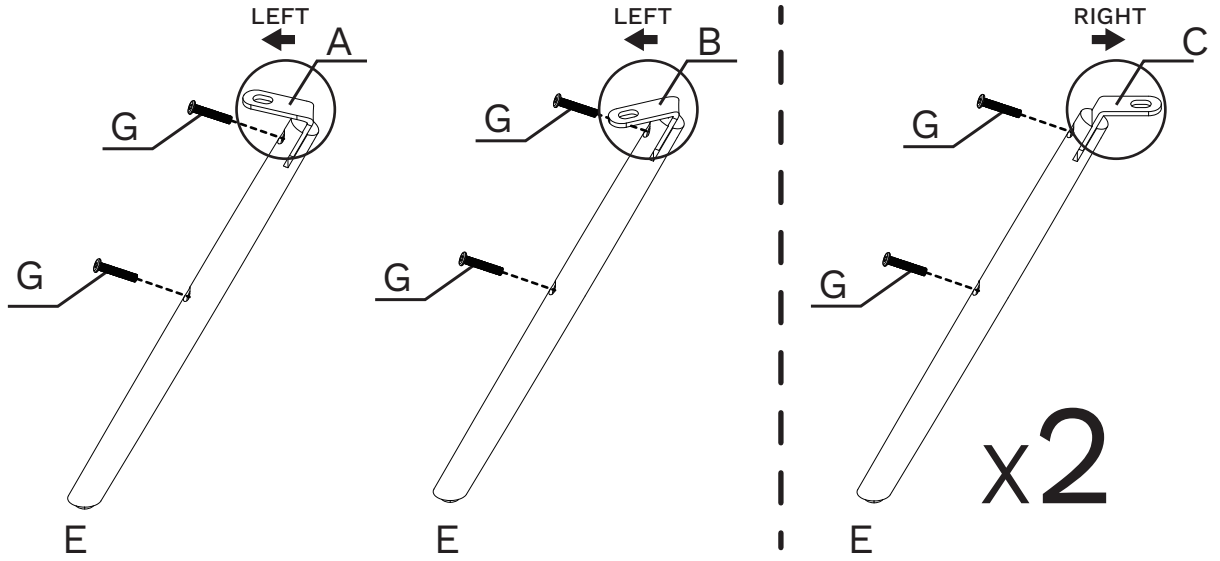
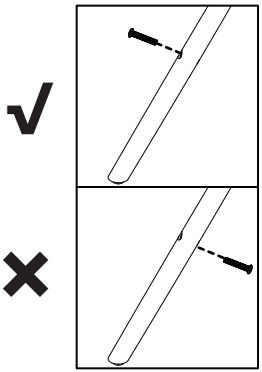

# STEP 2

Rotate and fix 20% by hand.

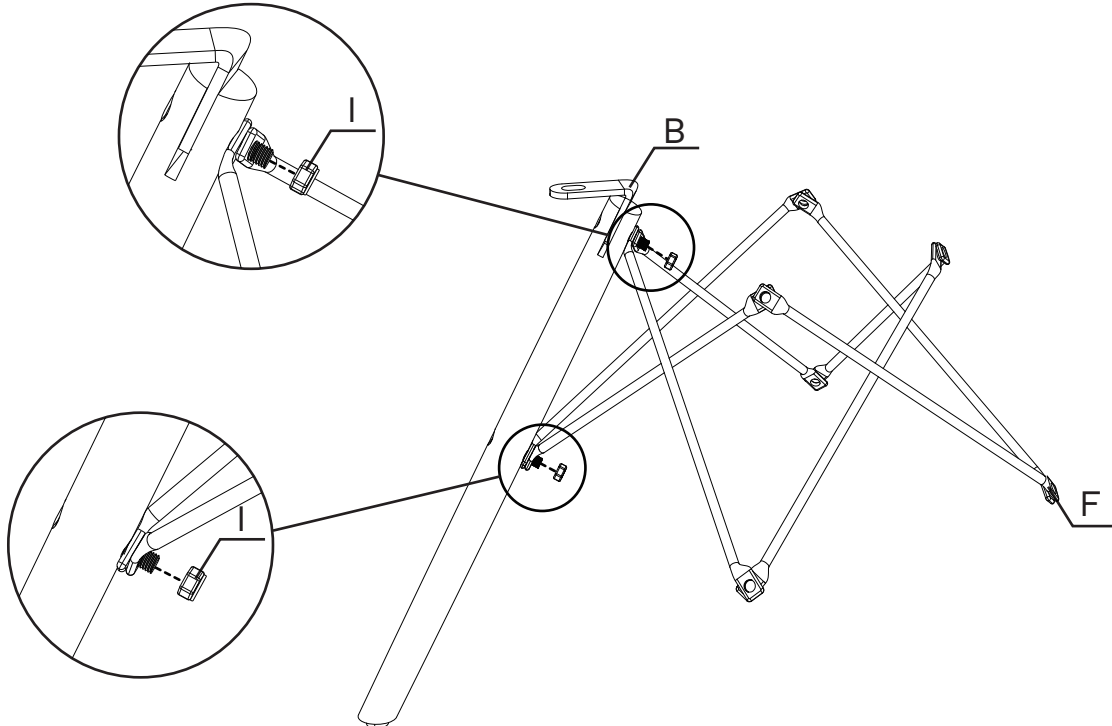

# STEP 3

Rotate and fix 20% by hand.

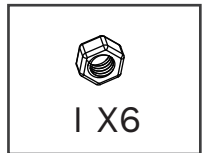
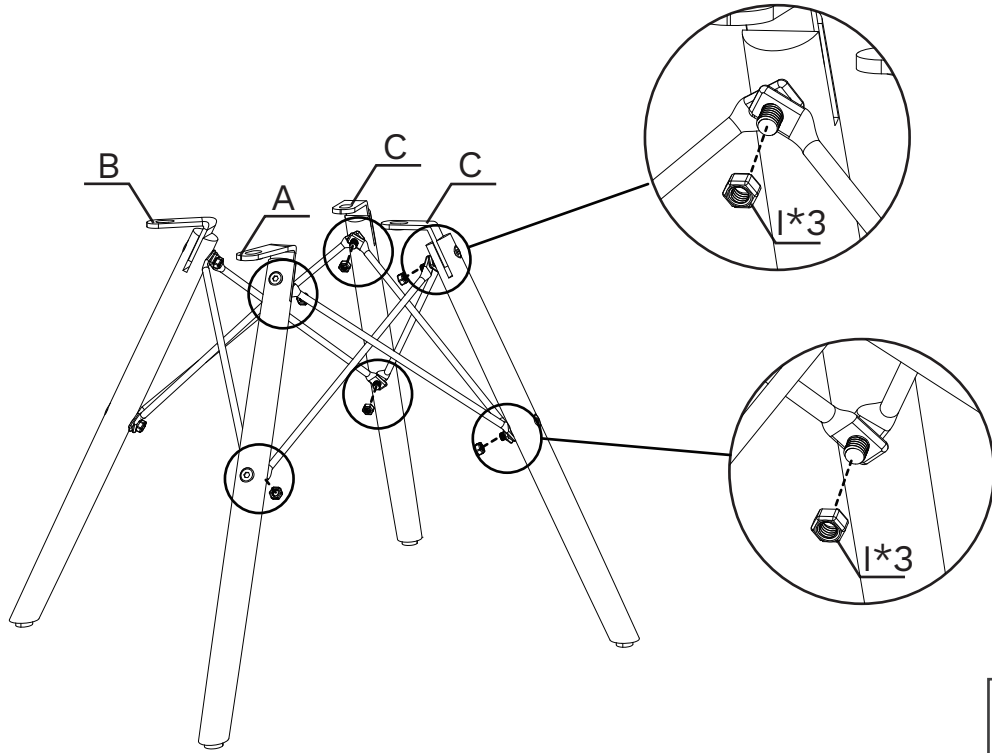

# STEP 4

After fixing L, rotate M to tighten all screws.

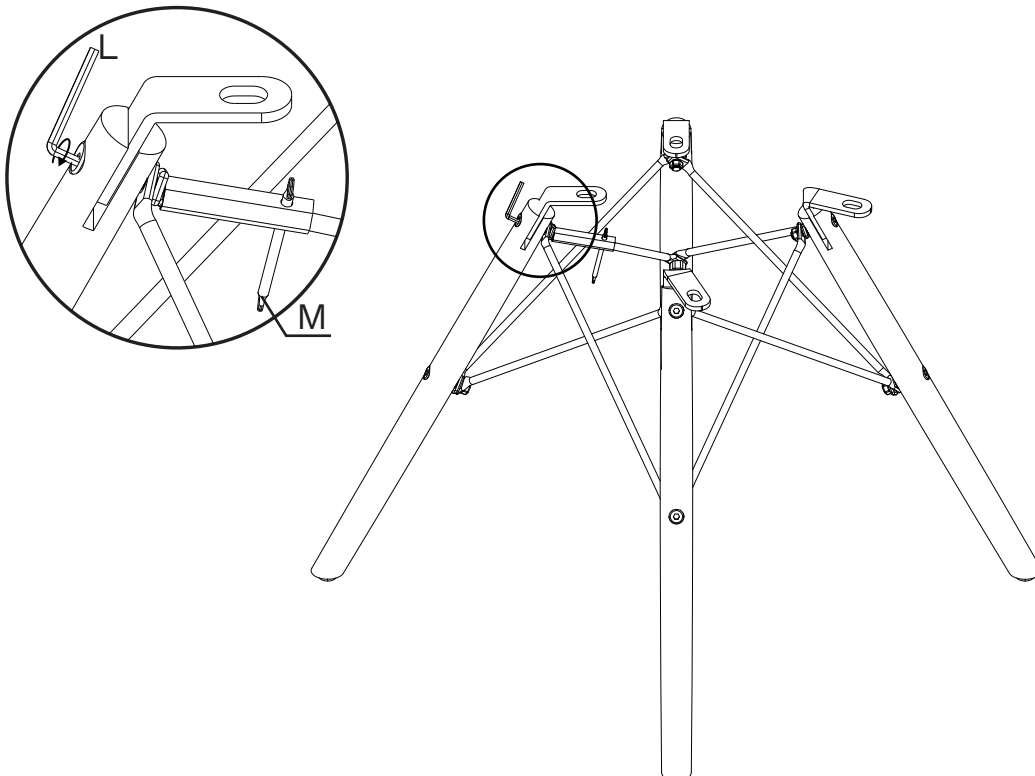

# STEP 5

Please remove the plastic cover before installing the seat.

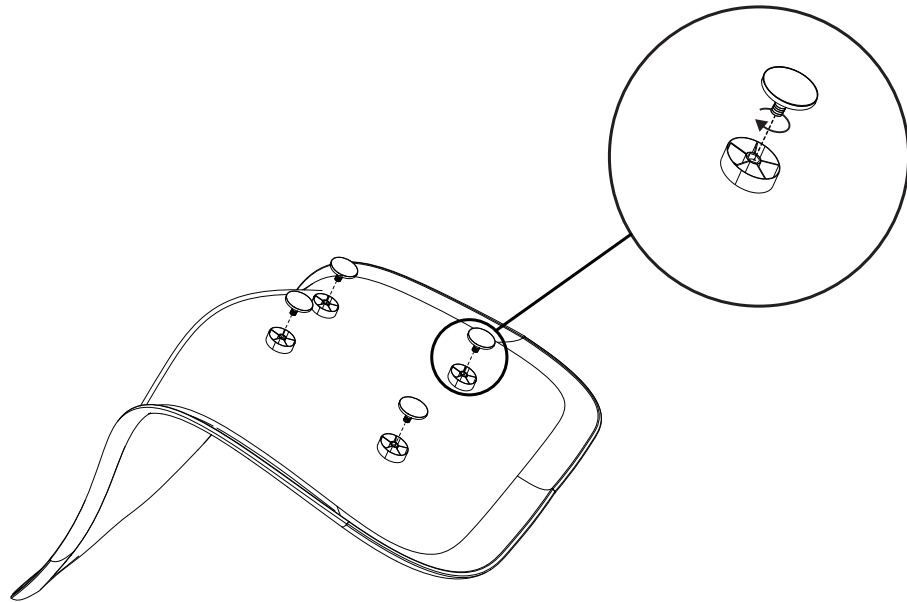

# STEP 6

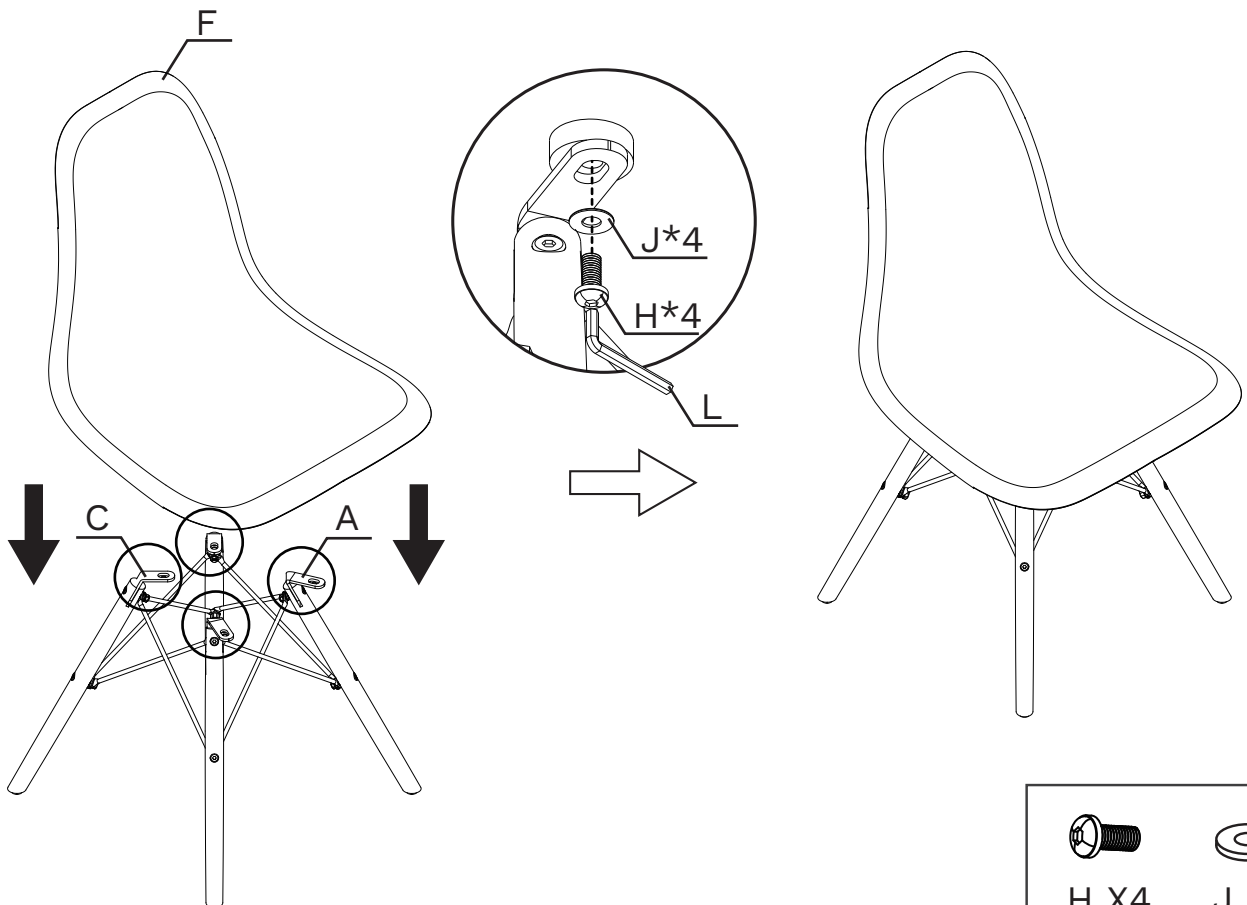

# STEP 7

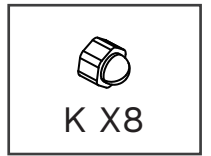
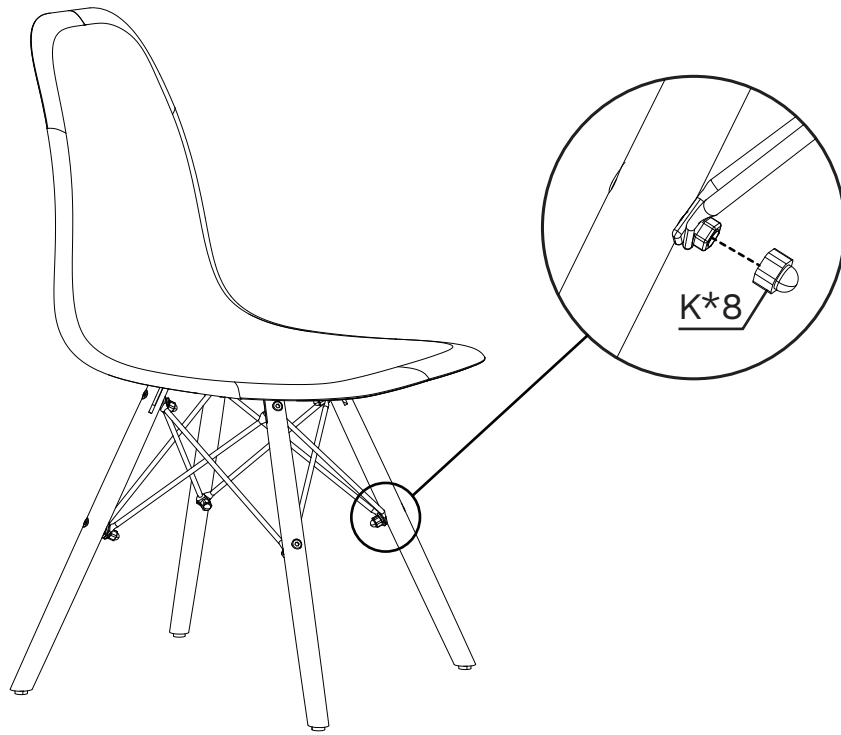

# FINISH

