

ASSEMBLY INSTRUCTIONS

*** Thank you for purchasing this quality product. Be sure to check all packing materials carefully for small parts which may have come loose inside the carton during shipment. Identify and count all parts and compare with parts list below.

*** Assemble product on a flat, soft surface such as a carpet or cloth to prevent scratching the finish. Read all instruction and study the drawings carefully before starting the assembly process.

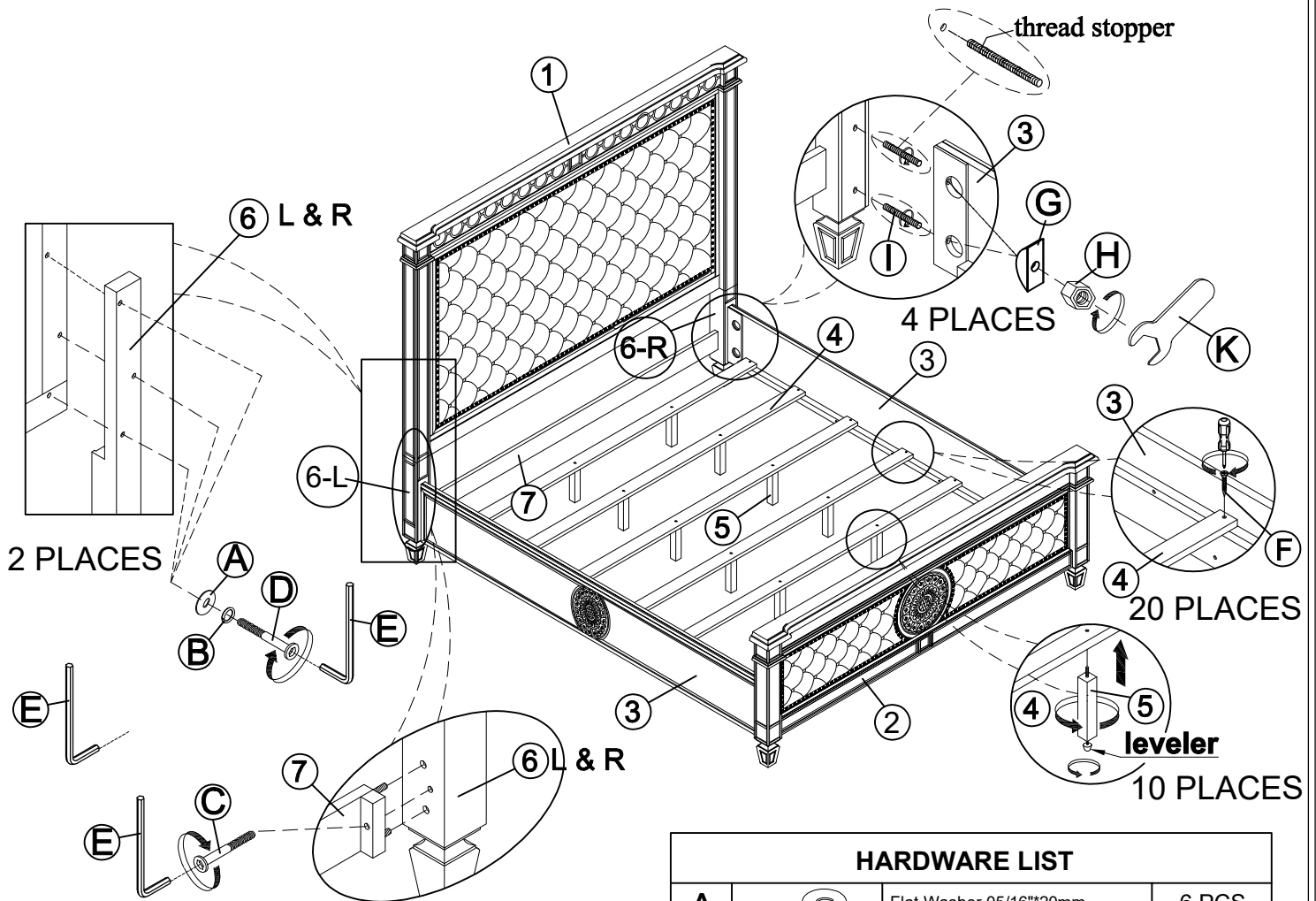

COMPONENT LIST

ITEM	DESCRIPTION	Q'Ty
1	Headboard Panel	1 PC
2	Footboard	1 PC
3	Rails	2 PCS
4	Slats	5 PCS
5	Slat supports	10 PCS
6	Legs (L & R)	2 PCS
7	Cross bar	1 PC

HARDWARE LIST

ITEM	DESCRIPTION	Q'Ty
A	Flat Washer 05/16**20mm	6 PCS
B	Lock Washer 05/16"	6 PCS
C	Bolt 05/16**1-5/8"L	4 PCS
D	Bolt 05/16**2"L	6 PCS
E	Allen Wrench (M4)	1 PC
F	P.H Screw (#8x1-1/4")	10 PCS
G	Half Moon	8 PCS
H	Bolt 05/16"	8 PCS
I	Bolt 05/16**3 1/2"L	8 PCS
J	Spanner Wrench 05/16"	1 PC