

ASSEMBLY INSTRUCTION

ASSEMBLY INSTRUCTION

ASSEMBLY TIPS:











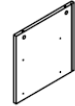

1. Remove hardware from box and sort by size.
2. Please check to see that all hardware and parts are present prior to start of assembly.
3. Please follow attached instructions in the same sequence as numbered to assure fast & easy assembly.

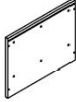

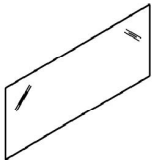
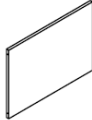
Warning !

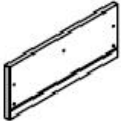
1. Don't attempt to repair or modify parts that are broken or defective. Please contact the store immediately.
2. This product is for home use only and not intended for commercial establishment.

PARTS IDENTIFICATION:

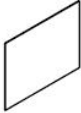
A	FRAME		1pc	H	CABINET SIDE PANEL		1pc
B	FRAME		1pc	I	CABINET SIDE PANEL		1pc
C	BACK PANEL		1pc	J	CABINET BOTTOM		1pc
D	IRON TUBE		2pcs	K	CABINET BACK PANEL		1pc
E	GLASS TOP		1pc	L	KEYBOARD		1pc
F	BRACE		1pc	M	DRAWER DOOR PANEL		2pcs
G	CABINET TOP		1pc	N	DRAWER BACK PANEL		2 pcs
				O	DRAWER SIDE PANEL		2pcs
				P	DRAWER SIDE PANEL		2pcs
				Q	DRAWER BOTTOM		2pcs

ASSEMBLY INSTRUCTION

ASSEMBLY TIPS:





1. Remove hardware from box and sort by size.
2. Please check to see that all hardware and parts are present prior to start of assembly.
3. Please follow attached instructions in the same sequence as numbered to assure fast & easy assembly.







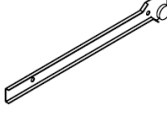





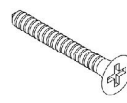



Warning !

1. Don't attempt to repair or modify parts that are broken or defective. Please contact the store immediately.
2. This product is for home use only and not intended for commercial establishment.

PARTS IDENTIFICATION:

R	SIDE GLIDE RAILS		2pcs
S	SIDE GLIDE RAILS		2pcs
T	SIDE GLIDE RAILS		2pcs
U	SIDE GLIDE RAILS		2pcs
V	SIDE GLIDE RAILS		2 pcs

Z	HARDWARE PACKAGE		
NO	DESCRIPTION	FIGURE	Q'TY
8	CAM LOCK		4 pcs
9	CAM LOCK		4 pcs
10	SUCTION CUP		6pcs
11	SCREW 3# X 38mm		12pcs
12	SCREW 3# X 12mm		24pcs
13	DOWEL		8pcs
14	FOOT PAD		4pcs
15	ALLEN KEY		1pc

Z HARDWARE PACKAGE			
NO	DESCRIPTION	FIGURE	Q'TY
1	WOOD DOWEL		4pcs
2	BOLT 3/16"X10mm		4pcs
3	BOLT 1/4"X12mm		4pcs
4	BOLT 1/4"X22mm		8pcs
5	BOLT		4pcs
6	BOLT 3*16"X28mm		2pcs
7	HANDLE		2pcs

STEP 1.

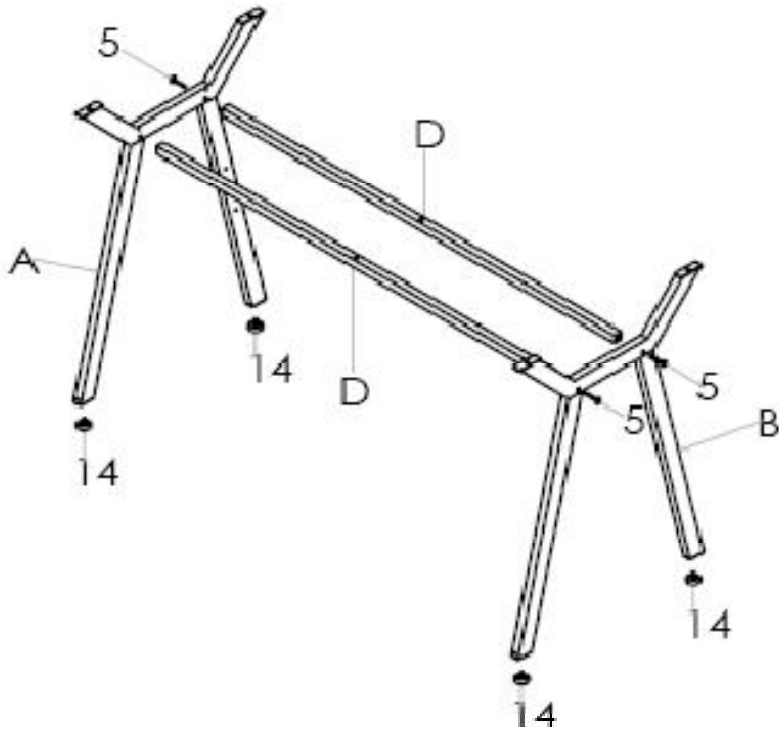

STEP 2.

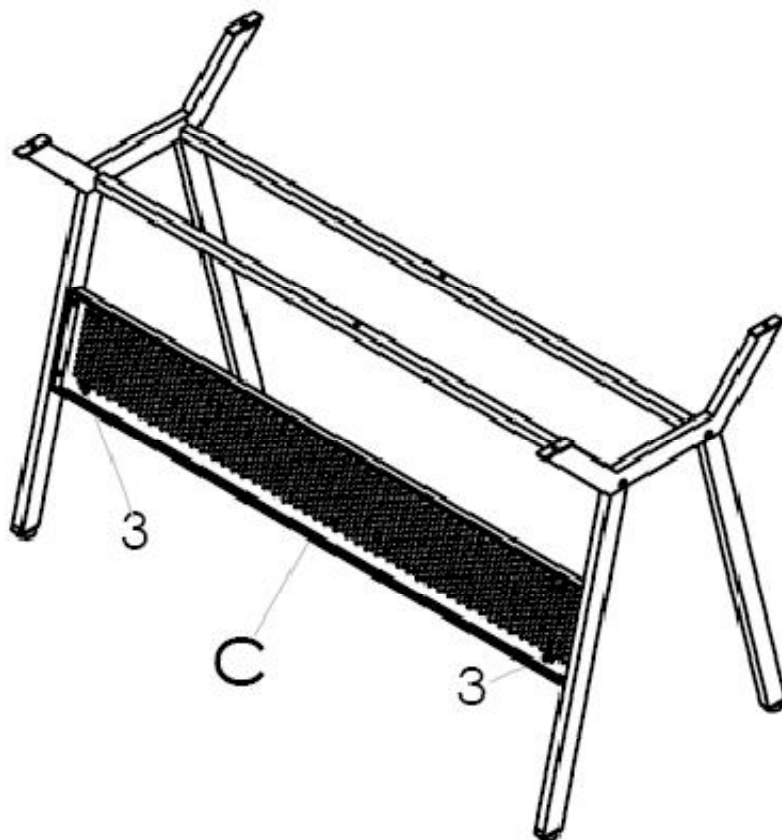

STEP 3.

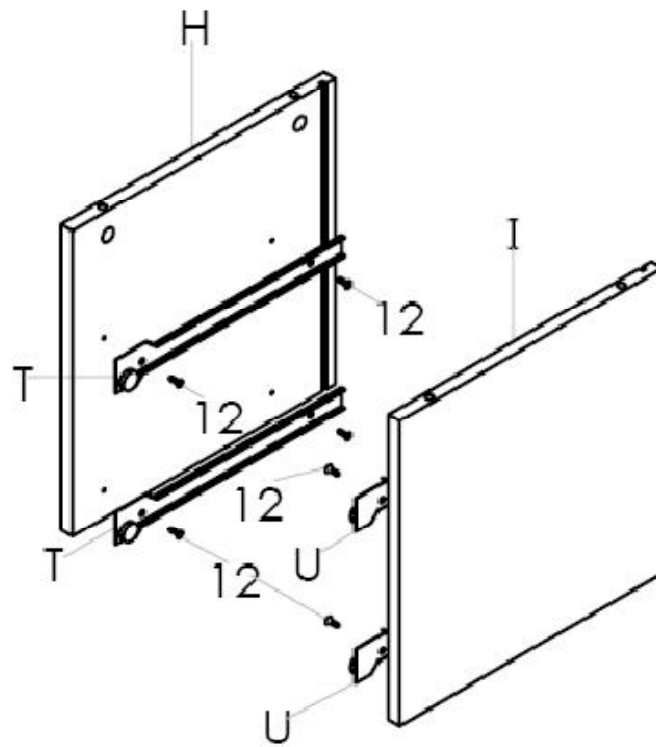

STEP 4.

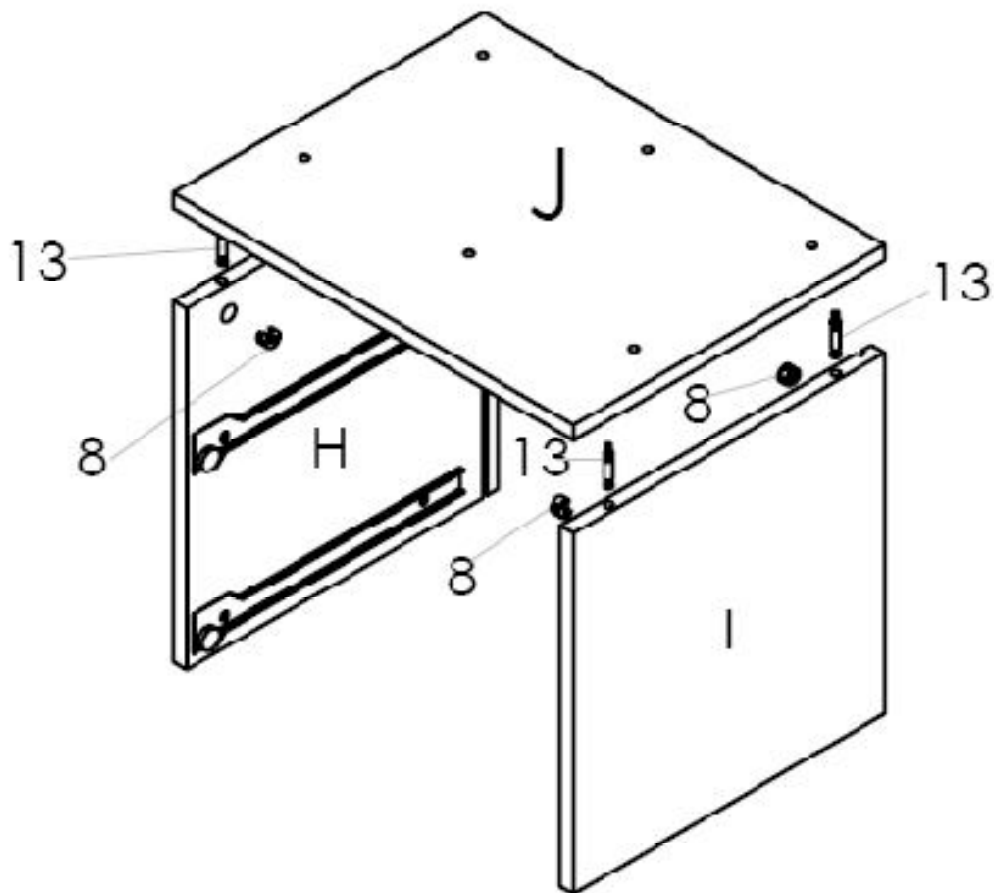

STEP 5.

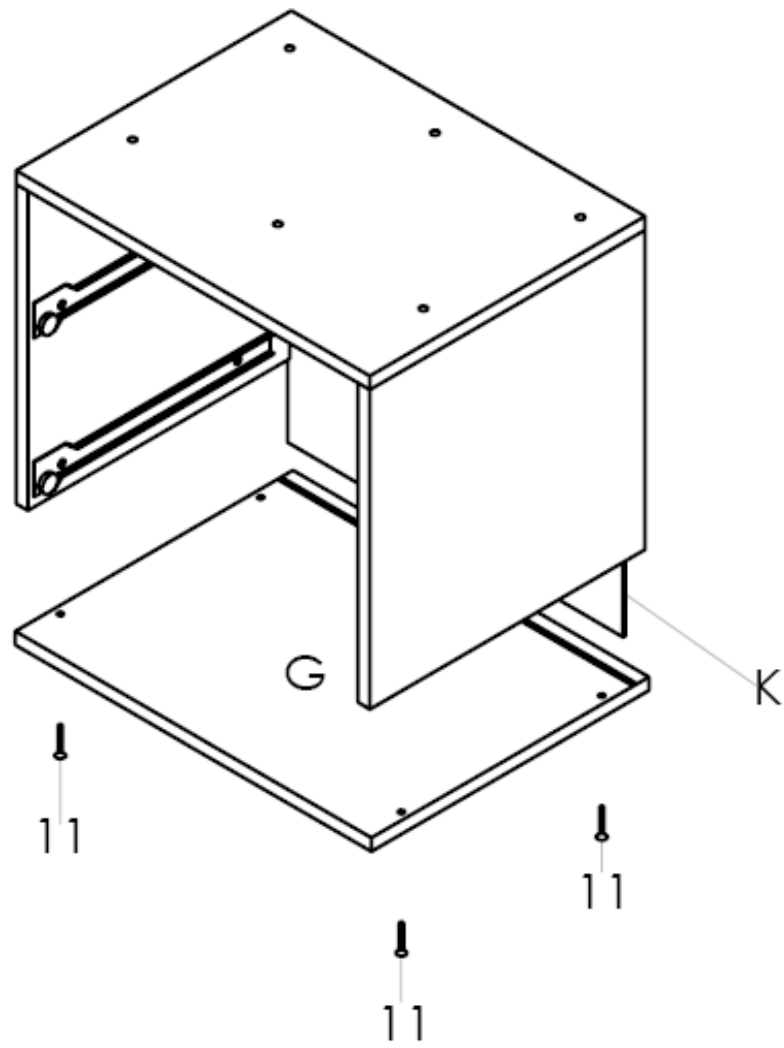

STEP 6.

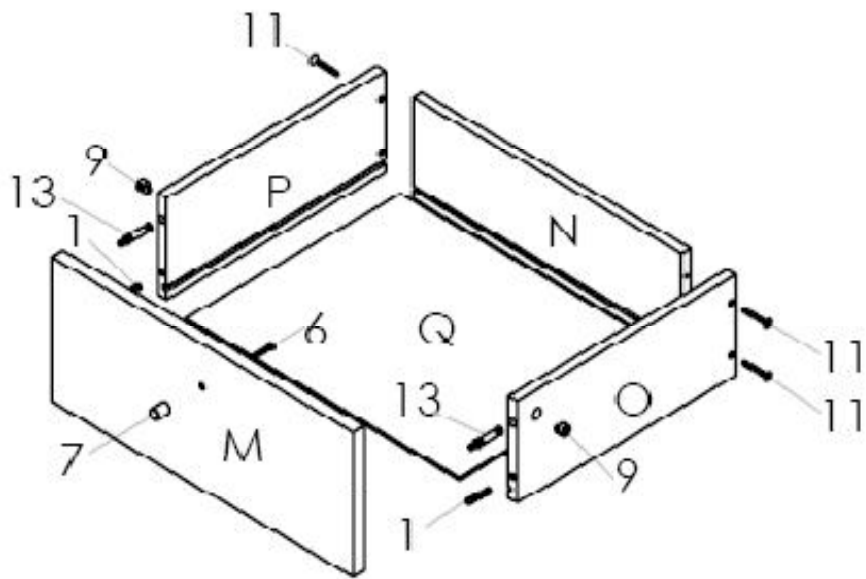

STEP 7.

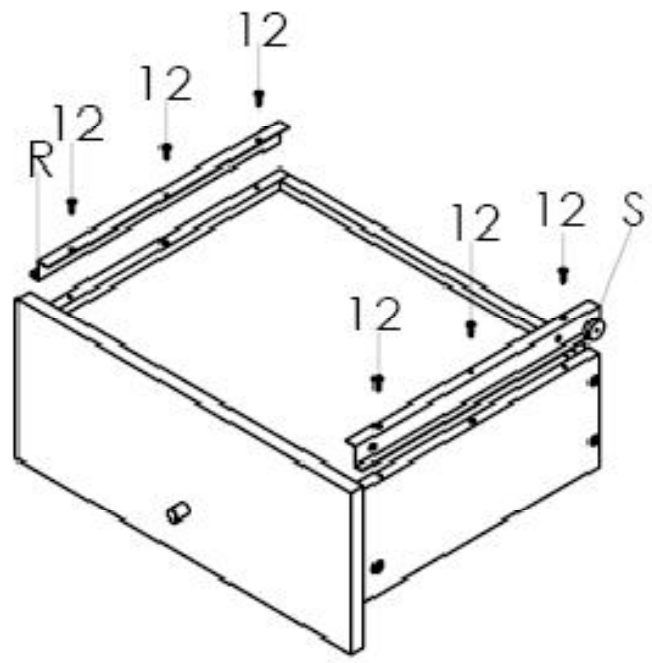

STEP 8.

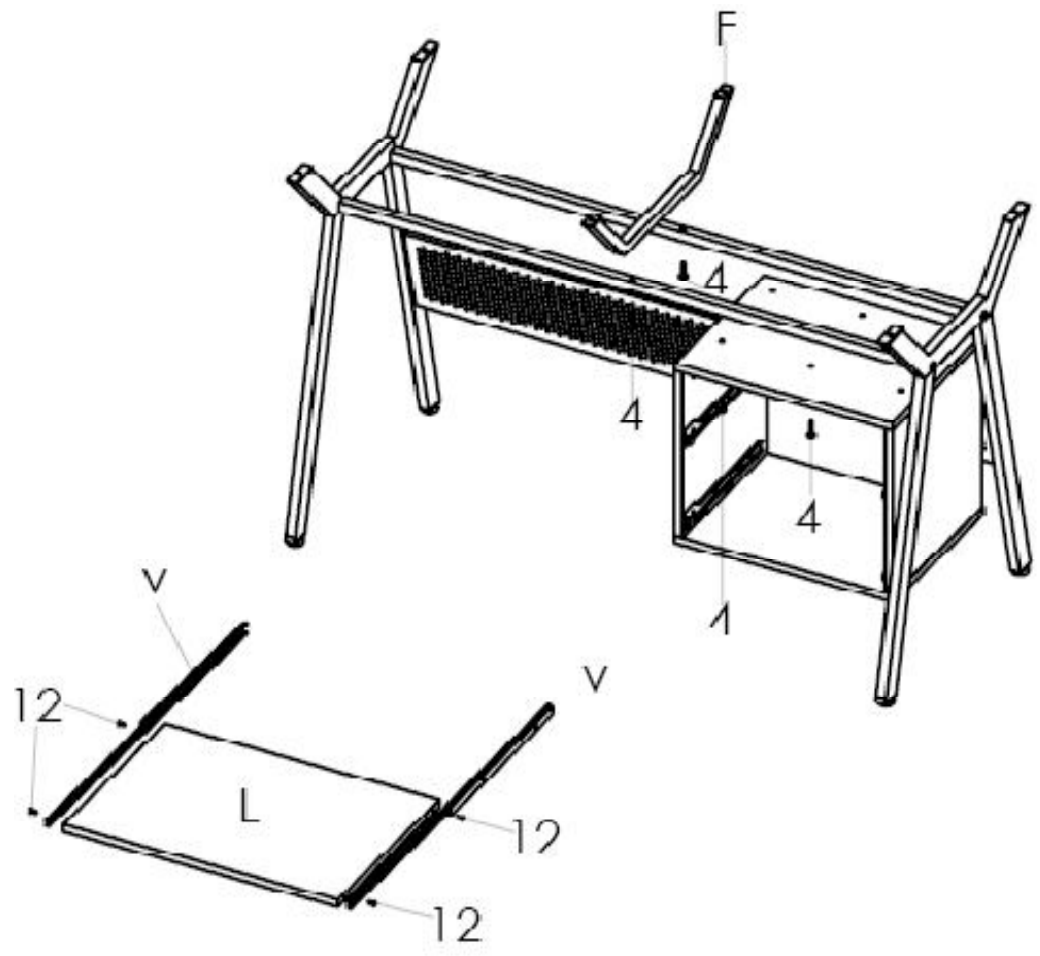

STEP 9.

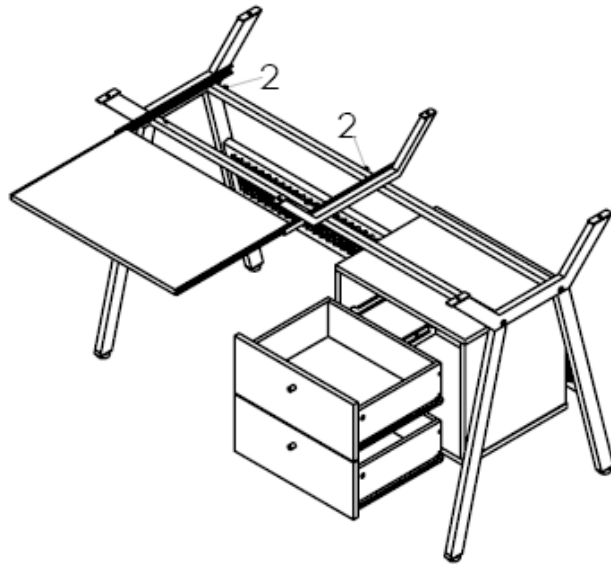

STEP 10.

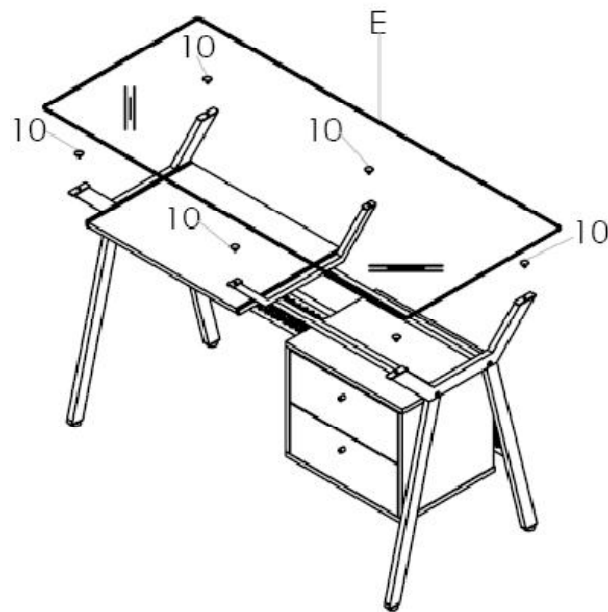

STEP 11.



ASSEMBLY INSTRUCTION

STEP 1 : Attach FOOT PADS (14) onto FRAME (A) & (B) by screwing into the legs. Assemble IRON TUBES (D) between FRAMES (A) & (B) using BOLTS (C).

STEP 2: Assemble BACK PANEL (C) between FRAMES (A) &(B) and using BOLTS (3).

STEP 3: Screw SIDE GLIDE RAILS (T) on CABINET SIDE PANEL (H) using SCREWS (12). Screw SIDE GLIDE RAILS (U) on CABINET SIDE PANEL (I) using SCREW (12).

STEP 4: Insert DOWELS (13) into (H) & (I) , then attach CABINET BOTTOM (J) using the CAM LOCKS (8).

STEP 5: Slide the CABINET BACK PANEL (K) between (H) & (I) and place the CABINET TOP (G) in place and secure using SCREW (11).

STEP 6: Assemble the DRAWER BACK PANEL (N) with DRAWER SIDE PANELS (O) & (P) using SCREW (11). Slide BOTTOM DRAWER (Q) between (O) & (P) . Insert DOWELS (13) and WOOD DOWELS (1) into (O) & (P) and attach the DRAWER DOOR PANEL (M) using the CAM LOCKS (9) . Finish the drawer by fastening the HANDLE (7) onto the drawer using BOLT (6).

STEP 7 : Assemble SIDE GLIDE RAILS (R) & (S) on the drawer using SCREWS (12).

STEP 8: Attach the BRACE (F) and the drawer frame completed in STEP 5 onto the IRON TUBES (D) using BOLTS(4). Fasten the SIDE GILDE RAILS (V) onto KEYBOARD (L) using SCREWS (12).

STEP 9 : Attach the SIDE GLIDE RAILS (V) from the previous step onto IRON TUBES (D) using BOLTS (2). Then , slide in the drawers completed in STEP 7.

STEP 10: Attach the SUCTION CUPS (10) and place the GLASS TOP (E) on top . Tighten all the hardware.

STEP 11 : Finished.