









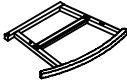
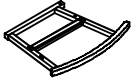

## Part List

PIECE	DESCRIPTION	PICTURE	QUANTITY
A	Back		1x
B	Seat		1x
C	Left side		1x
D	Right side		1x
E	Seat bar		2x
F	Support leg		1x

## Hardware List

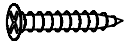
PIECE	DESCRIPTION	PICTURE	QUANTITY
HW1	T Bolt & nut	 M6x70	4x
HW2	Bolt	 M6x45	4x
HW3	Allen screw	 M6x70	2x
HW4	Screw	 M4x35	2x
HW5	Extra Bolt	 M6x45	1x
HW6	Allen Key		1x

## Installation & Assembly

Product Dimension: 22.44" W x 31.10"D x 35.43"H

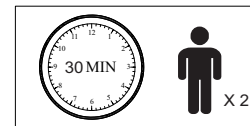
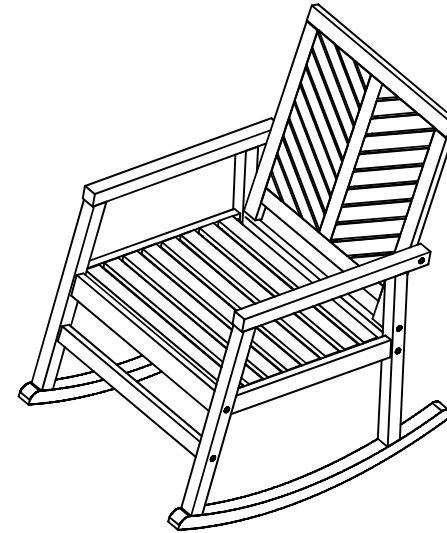



WEIGHT CAPACITY: 275 LBS  
WARNING: DO NOT STAND ON CHAIR

# PREPARATION

Tool required for assembly (included): Allen Key.

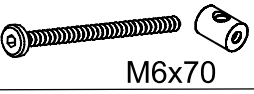
**1**

HW1	 M6x70	2x
HW2	 M6x45	2x
HW3	 M6x70	1x

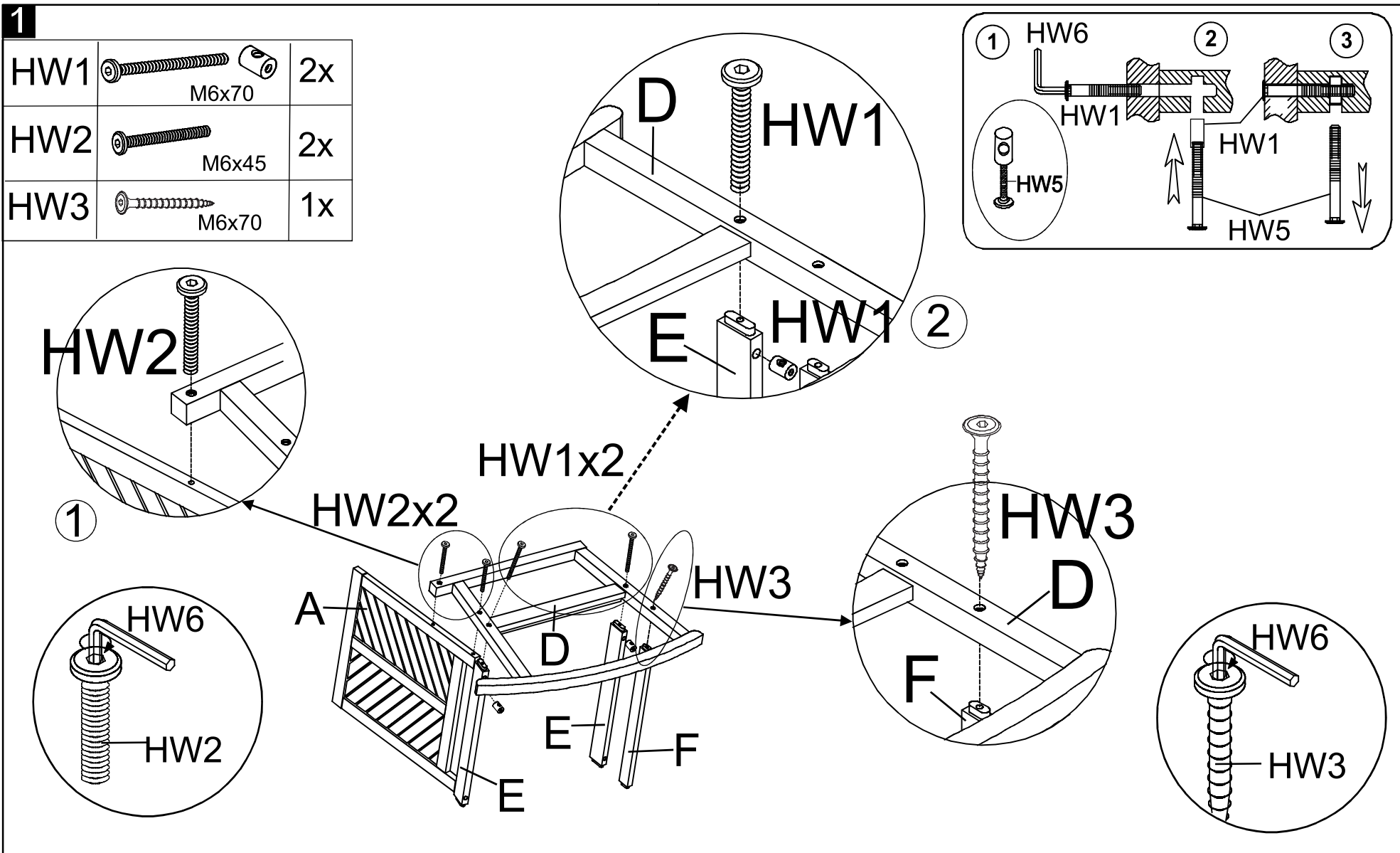



Step 1: Attach the Back (A), Seat Bar (E), Support Leg (F) to the Right side (D) as shown on the picture. Using the T bolt & nut (HW1), Bolt (HW2) and Allen screw (HW3) to fix it together by using the Allen key (HW6) and Extra bolt (HW5) as shown on these pictures.

## PREPARATION

Tool required for assembly (included): Allen Key.

**2**

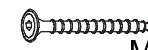
HW1	 M6x70	2x
HW2	 M6x45	2x
HW3	 M6x70	1x

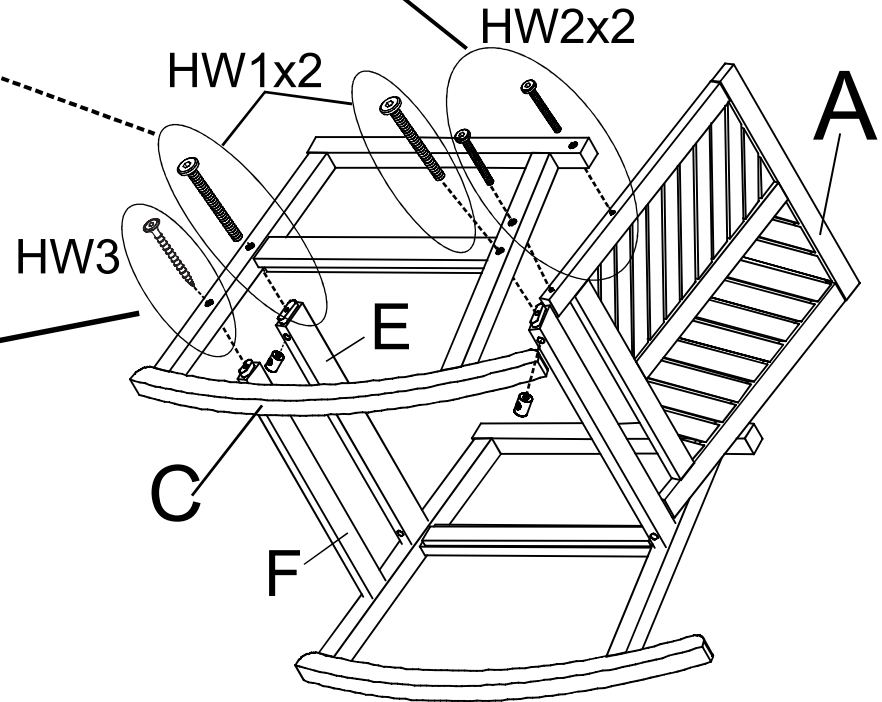
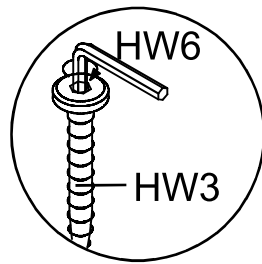
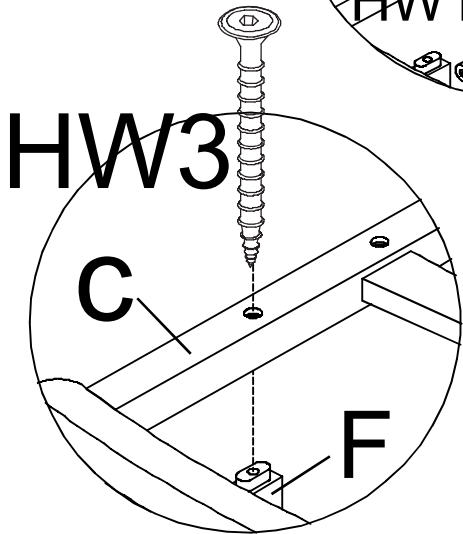
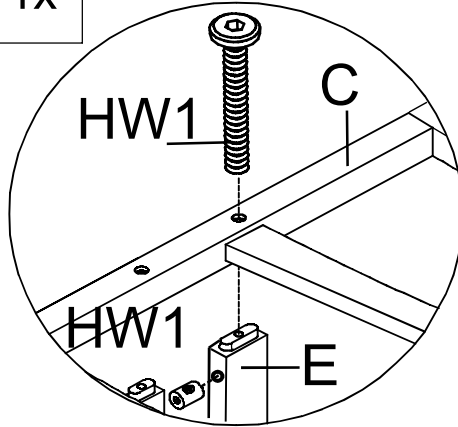
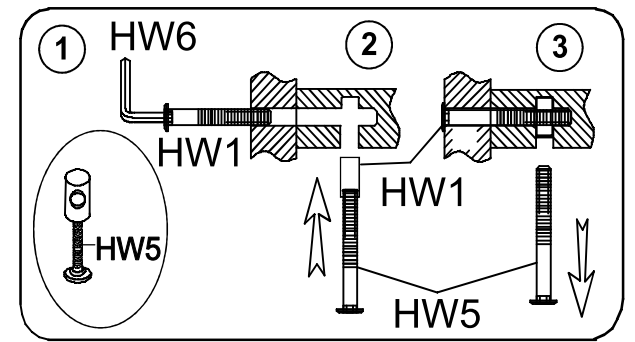
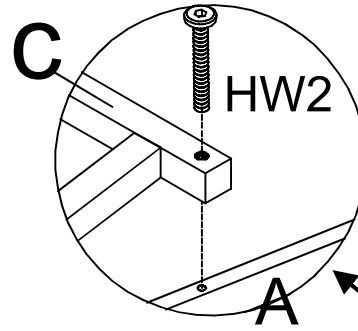
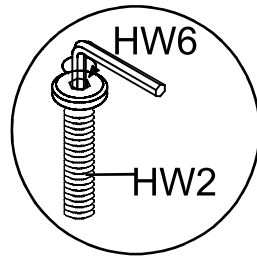

Step 2: Attach the Left side(C) to Seat Bar (E) , Support Leg (F) and the Back (A) as shown on the picture .Using the T bolt &nut (HW1) , Bolt (HW2) , Allen screw (HW3) to fix all together by using the Allen key (HW6) and Extra bolt (HW5) as shown on these pictures .

## PREPARATION

Tool required for assembly : Screw driver.

3

HW4

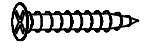

M4x35

2x

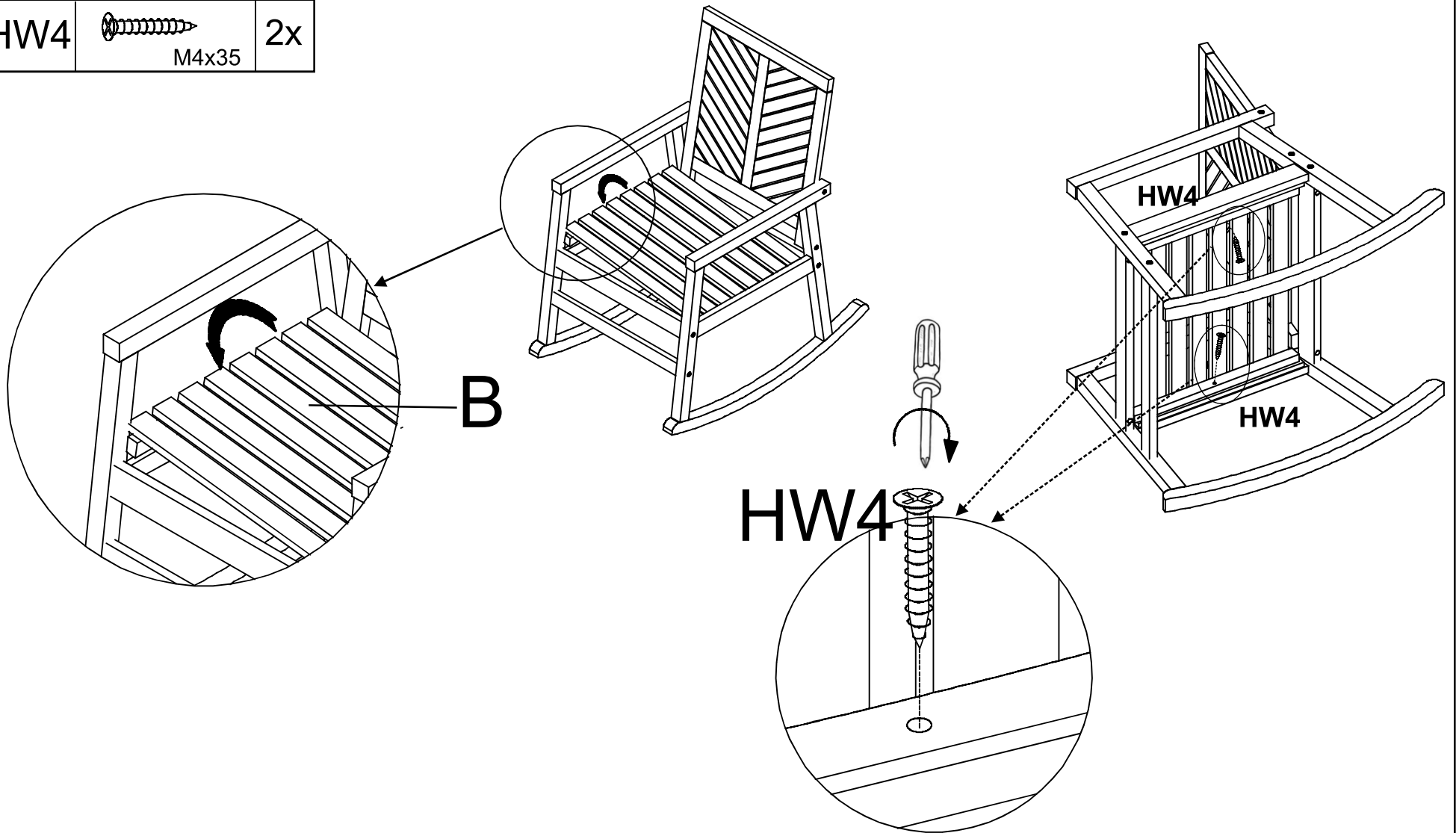

Step 3: Put the Seat (B) to the chair and using the Screw (HW4) to fix it by the Screw driver as shown on the picture .