



*ASSEMBLY INSTRUCTIONS*  
*COASTER FINE FURNITURE*



*Fine Furniture for every stage of life*

**360121 (B1&B2)**  
***Daybed***

# ITEM: 360121(B1&B2)



## ASSEMBLY INSTRUCTIONS

### ASSEMBLY TIPS:

1. Remove hardware from box and sort by size.
2. Please check to see that all hardware and parts are present prior to start of assembly.
3. Please follow attached instructions in the same sequence as numbered to assure fast & easy assembly.



### WARNING!

1. Don't attempt to repair or modify parts that are broken or defective. Please contact the store immediately.
2. This product is for home use only and not intended for commercial establishments.



ASSEMBLY TIME

15 MINUTES

## PARTS IDENTIFICATION

### B1 (BOX 1)

A RIGHT SIDE PANEL  
( WITH "A" LABEL)



1PC

B LEFT SIDE PANEL  
( WITH "B" LABEL)

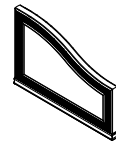

1PC

C RIGHT LEG



2PCS

D LEFT LEG



2PCS

E ROLL SLAT  
(13PCS)

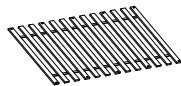

1SET

### B2 (BOX 2)

F BACK PANEL

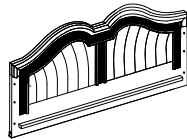

1PC

G FRONT RAIL



1PC

## HARDWARE IDENTIFICATION

### Z-B1(BOX 1) - HARDWARE PACK IS LOCATED IN 360121 (B1)

1 BOLT  
( $\Phi$ 5/16" x 55 mm - RBW)

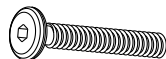

14PCS

2 LOCK WASHER  
( $\Phi$ 5/16" - RBW)



14PCS

3 FLAT WASHER  
( $\Phi$ 5/16" - RBW)



14PCS

4 ALLEN WRENCH  
(4MM - RBW)



1PC

5 THREADED BOLT  
( $\Phi$ 5/16" x 90MM - RBW)



4PCS

6 HALF ROUND NUT  
( $\Phi$ 5/16" - RBW)



4PCS

7 HEX NUT  
( $\Phi$ 5/16" x 14MM - RBW)



4PCS

8 WRENCH  
(14MM - RBW)



1PC

9 FLAT HEAD SCREW  
( $\Phi$ 4 x 30MM - RBW)



10PCS

ITEM: **360121(B1&B2)**

**ASSEMBLY INSTRUCTIONS**

**STEP 1**

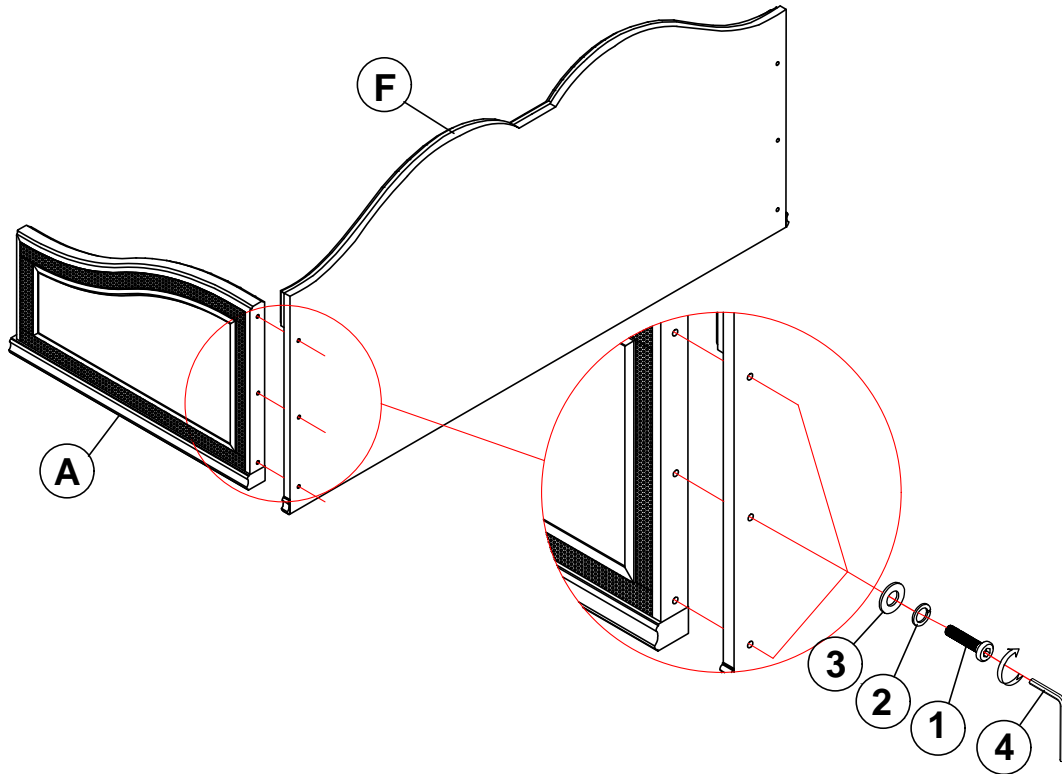

**STEP 2**

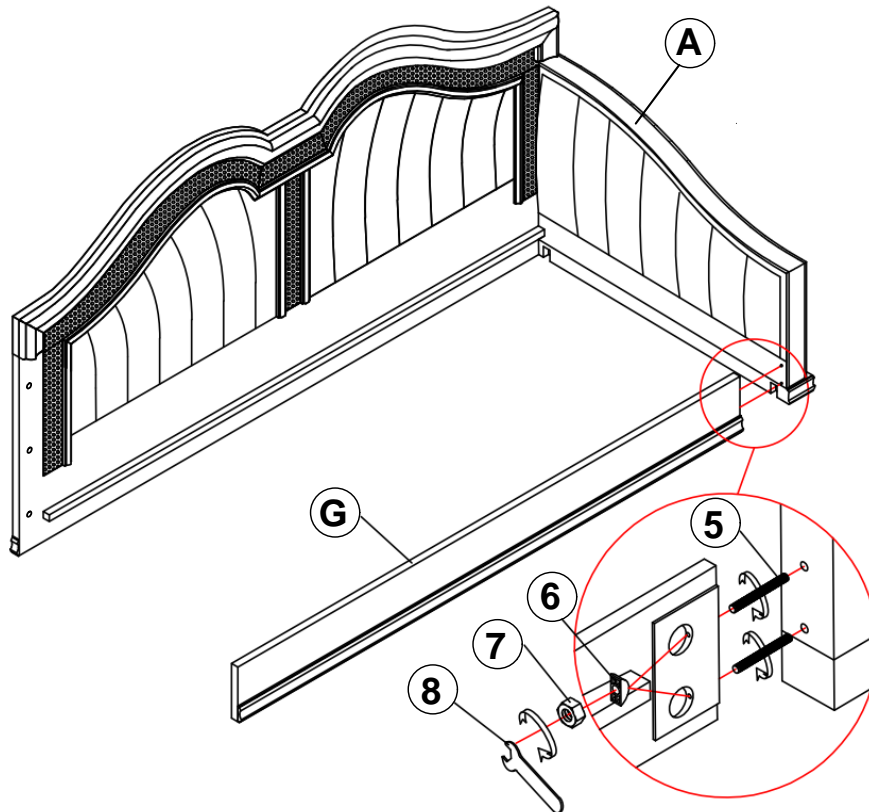

ITEM: **360121(B1&B2)**

**ASSEMBLY INSTRUCTIONS**

**STEP 3**

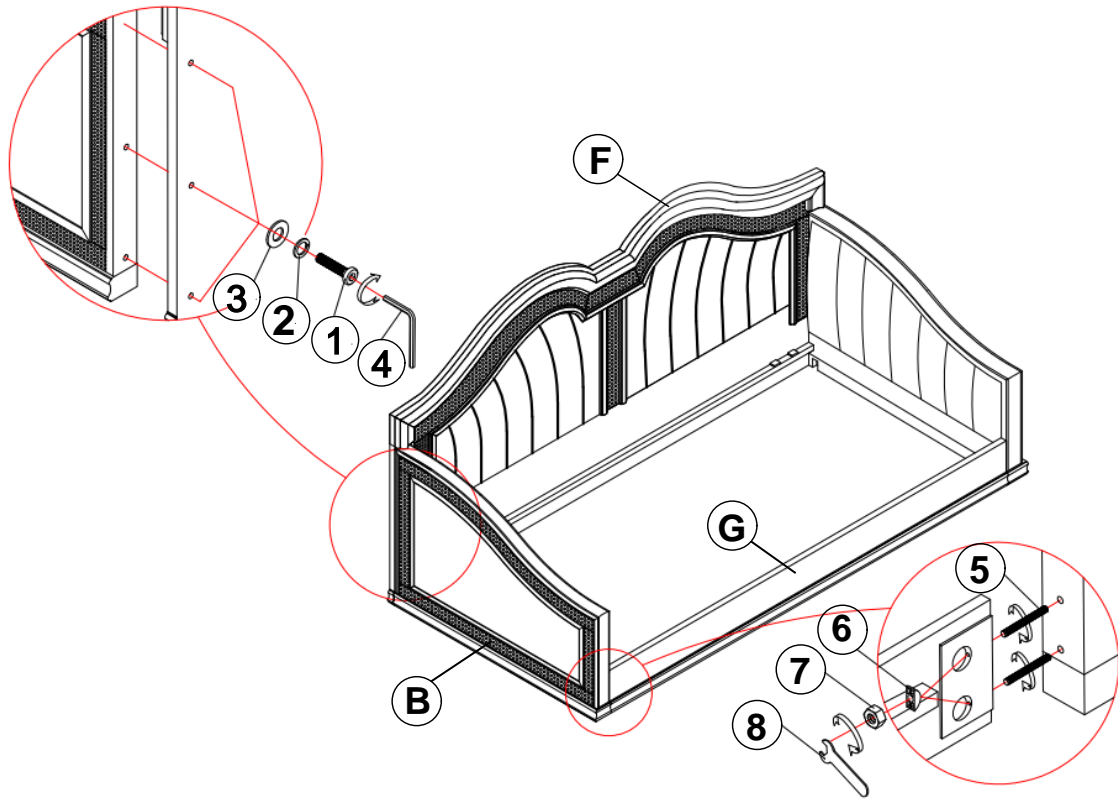

**STEP 4**

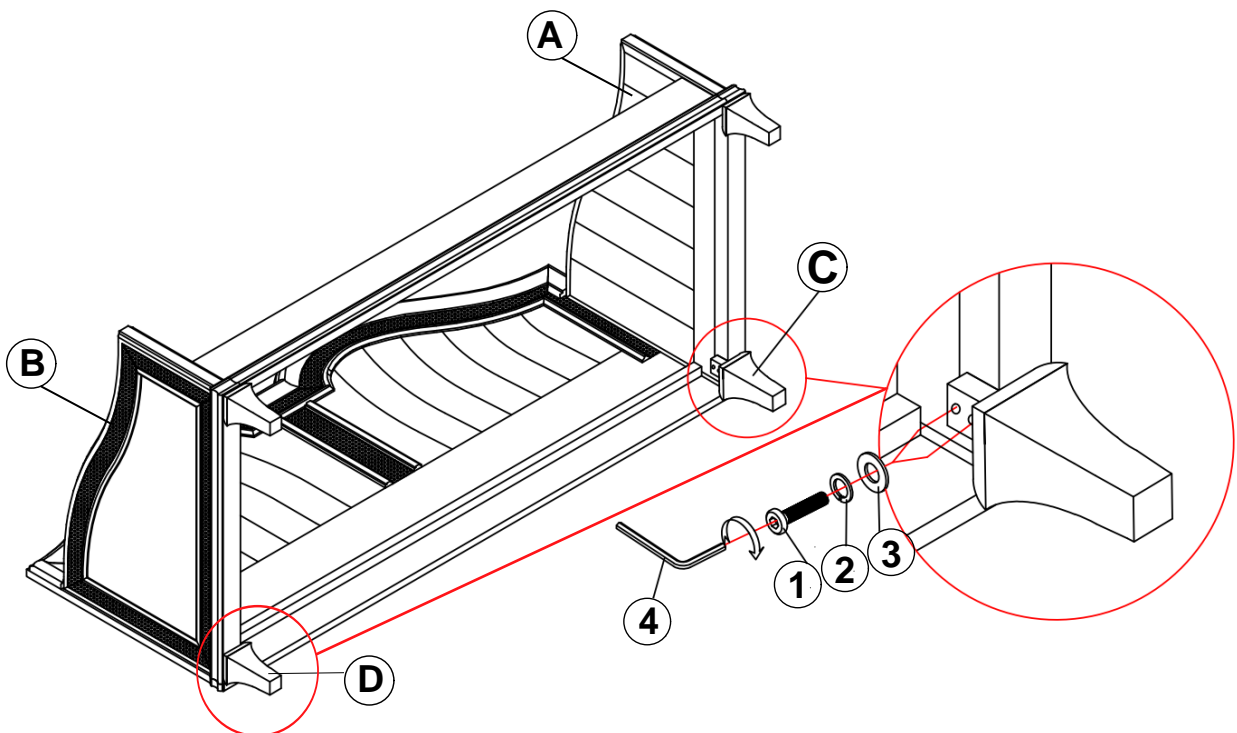

ITEM: **360121(B1&B2)**

**ASSEMBLY INSTRUCTIONS**

**STEP 5**

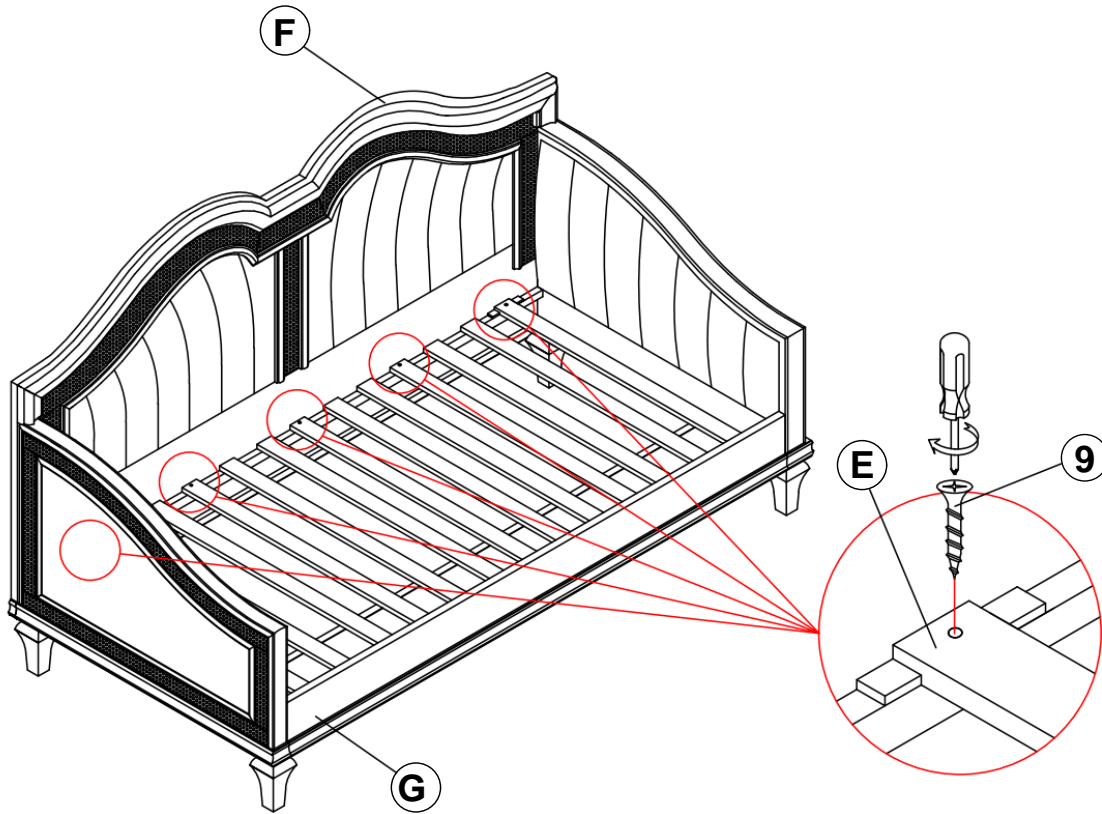

**STEP 6**  
**COMPLETE**

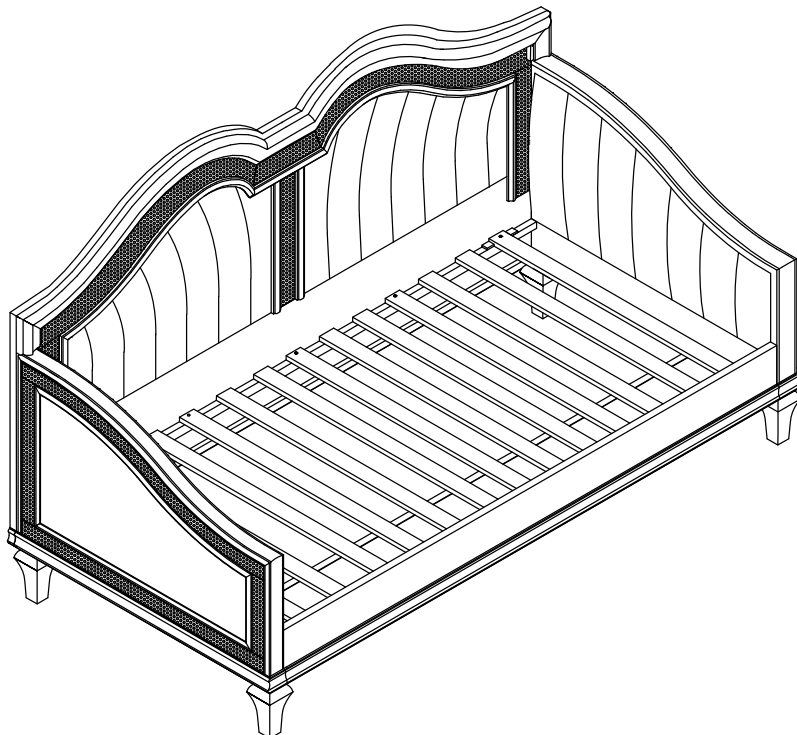

ITEM: **360121(B1&B2)**



Inner Size : 78.75"W X 39.75"D

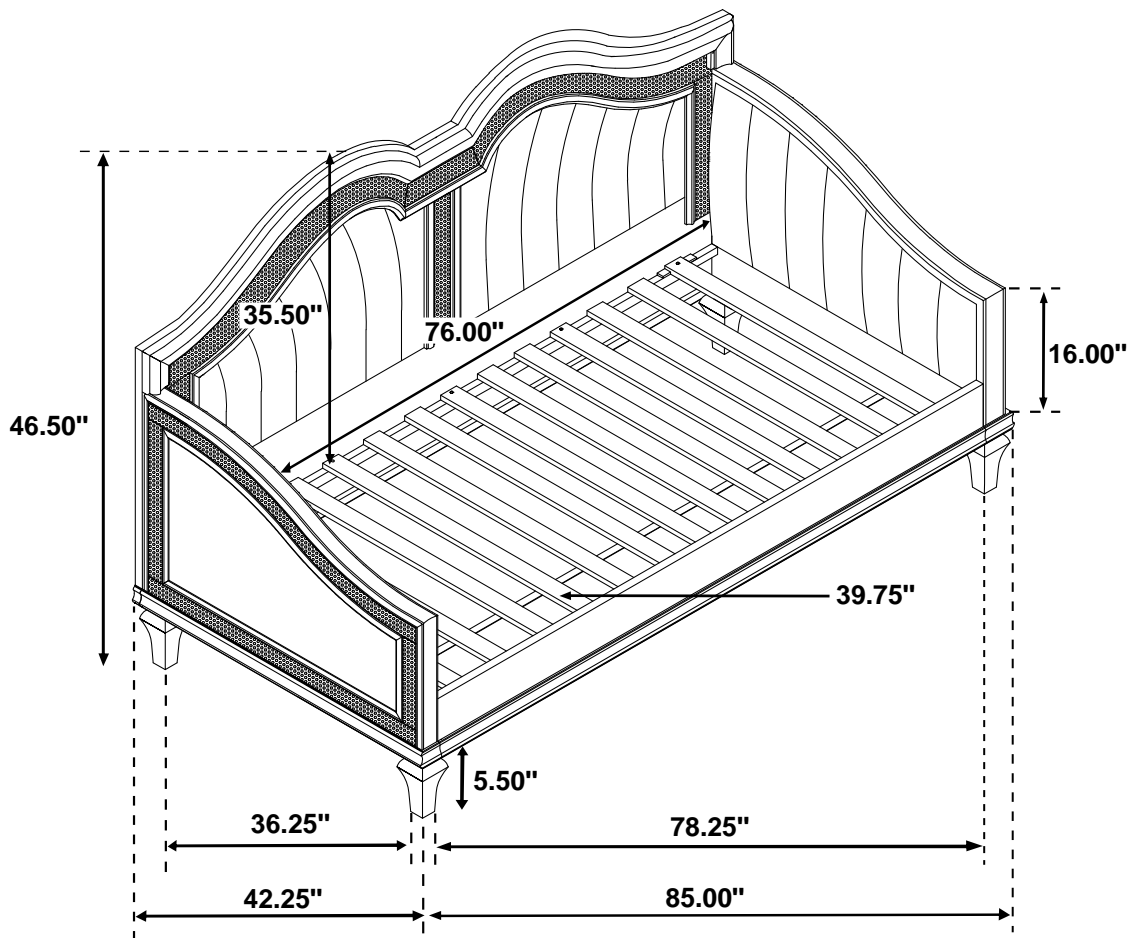

Note: Dimension tolerance  $\pm 5\%$