

MANUEL D'INSTRUCTION INSTRUCTION MANUAL

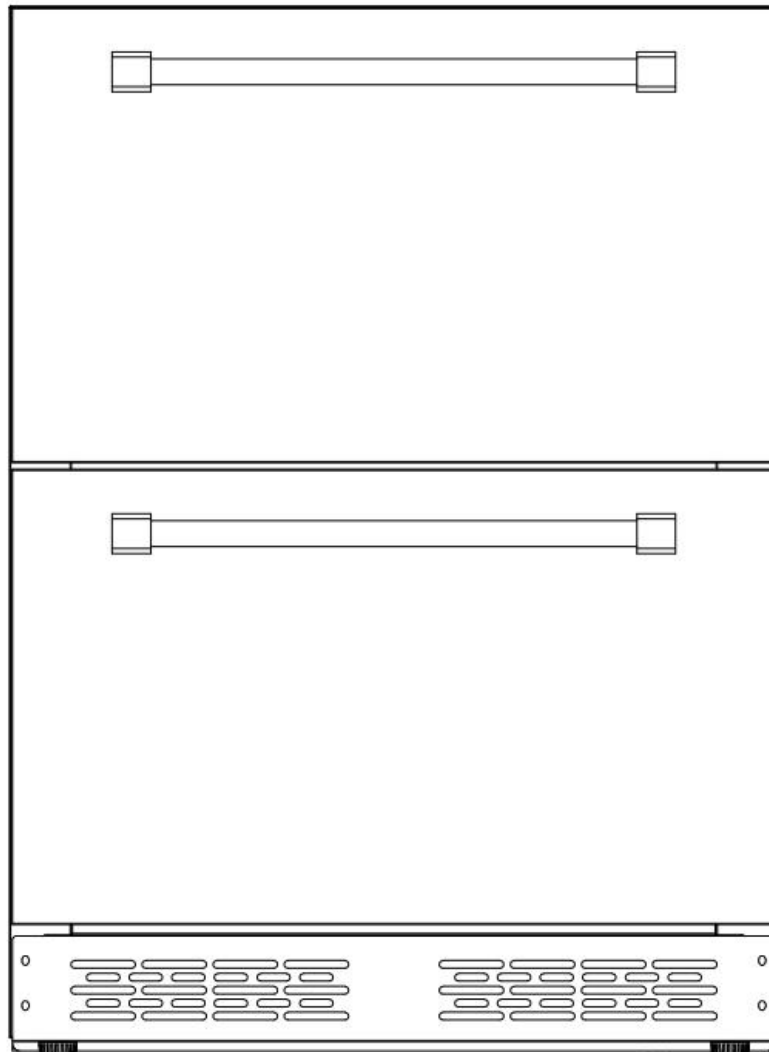

MODEL:BC-145WS BC-145WSBP BD-145WS BD-145WSBP BCD-145WD BCD-145WDBP BJ-145WD BJ-145WDBP

**BEFORE USE, PLEASE READ AND FOLLOW
ALL SAFETY RULES AND OPERATING INSTRUCTIONS.**

SPECIFICATIONS

<i>Model</i>	BC-145WS	<i>Ampérage Amperage</i>	1.2A
<i>Type de produit Product Type</i>	Fridger de service Service Fridge	<i>Courant Input Power</i>	98W
<i>Capacité Capacity</i>	145 Litres	<i>Réfrigérant Refrigerant</i>	R600a 37g
<i>T° zone Zone T°</i>	1-10°C 34-50°F	<i>Dimensions (Largeur x profondeur x hauteur) (Width x Depth x Height)</i>	23.5' x 22' x 32.2'~34.2' 595 x 560 x 820~870mm
<i>Voltage / Fréquence Voltage / Frequency</i>	AC 115V ~ 60Hz	<i>Poids Net Net Weight</i>	98 lbs

<i>Model</i>	BC-145WSBP	<i>Ampérage Amperage</i>	1.2A
<i>Type de produit Product Type</i>	Fridger de service Service Fridge	<i>Courant Input Power</i>	98W
<i>Capacité Capacity</i>	145 Litres	<i>Réfrigérant Refrigerant</i>	R600a 37g
<i>T° zone Zone T°</i>	1-10°C 34-50°F	<i>Dimensions (Largeur x profondeur x hauteur) (Width x Depth x Height)</i>	23.5' x 22' x 32.2'~34.2' 595 x 560 x 820~870mm
<i>Voltage / Fréquence Voltage / Frequency</i>	AC 115V ~ 60Hz	<i>Poids Net Net Weight</i>	98 lbs

<i>Model</i>	BD-145WS	<i>Ampérage Amperage</i>	1.5A
<i>Type de produit Product Type</i>	Fridger de service Service Fridge	<i>Courant Input Power</i>	115W
<i>Capacité Capacity</i>	145 Litres	<i>Réfrigérant Refrigerant</i>	R600a 45g

T° zone Zone T°	-18-0°C -1-32°F	Dimensions (Largeur x profondeur x hauteur) (Width x Depth x Height)	23.5' x 22' x 32.2'~34.2' 595 x 560 x 820~870mm
Voltage / Fréquence Voltage / Frequency	AC 115V ~ 60Hz	Poids Net Net Weight	100 lbs

Model	BD-145WSBP	Ampérage Amperage	1.5A
Type de produit Product Type	Fridger de service Service Fridge	Courant Input Power	115W
Capacité Capacity	145 Litres	Réfrigérant Refrigerant	R600a 45g
T° zone Zone T°	-18-0°C -1-32°F	Dimensions (Largeur x profondeur x hauteur) (Width x Depth x Height)	23.5' x 22' x 32.2'~34.2' 595 x 560 x 820~870mm
Voltage / Fréquence Voltage / Frequency	AC 115V ~ 60Hz	Poids Net Net Weight	100 lbs

Model	BCD-145WD	Ampérage Amperage	1.5A
Type de produit Product Type	Fridger de service Service Fridge	Courant Input Power	115W
Capacité Capacity	145 Litres	Réfrigérant Refrigerant	R600a 45g
T° zone Zone T°	DN -18-0°C UP 0-10°C DN -1-32°F UP 32-50°F	Dimensions (Largeur x profondeur x hauteur) (Width x Depth x Height)	23.5' x 22' x 32.2'~34.2' 595 x 560 x 820~870mm
Voltage / Fréquence Voltage / Frequency	AC 115V ~ 60Hz	Poids Net Net Weight	105 lbs

Model	BCD-145WDBP	Ampérage Amperage	1.5A
Type de produit Product Type	Fridger de service Service Fridge	Courant Input Power	115W
Capacité Capacity	145 Litres	Réfrigérant Refrigerant	R600a 45g
T° zone Zone T°	DN -18-0°C UP 0-10°C DN -1-32°F UP 32-50°F	Dimensions (Largeur x profondeur x hauteur) (Width x Depth x	23.5' x 22' x 32.2'~34.2' 595 x 560 x 820~870mm

		Height)	
Voltage / Fréquence Voltage / Frequency	AC 115V ~ 60Hz	Poids Net Net Weight	105 lbs

<i>Model</i>	BJ-145WD	Ampérage Amperage	1.2A
Type de produit Product Type	Fridger de service Service Fridge	Courant Input Power	98W
Capacité Capacity	145 Litres	Réfrigérant Refrigerant	R600a 37g
T° zone Zone T°	DN 1-10°C UP 10-22°C DN 34-50°F UP 50-72°F	Dimensions (Largeur x profondeur x hauteur) (Width x Depth x Height)	23.5' x 22' x 32.2'~34.2' 595 x 560 x 820~870mm
Voltage / Fréquence Voltage / Frequency	AC 115V ~ 60Hz	Poids Net Net Weight	105 lbs

<i>Model</i>	BJ-145WDBP	Ampérage Amperage	1.2A
Type de produit Product Type	Fridger de service Service Fridge	Courant Input Power	98W
Capacité Capacity	145 Litres	Réfrigérant Refrigerant	R600a 37g
T° zone Zone T°	DN 1-10°C UP 10-22°C DN 34-50°F UP 50-72°F	Dimensions (Largeur x profondeur x hauteur) (Width x Depth x Height)	23.5' x 22' x 32.2'~34.2' 595 x 560 x 820~870mm
Voltage / Fréquence Voltage / Frequency	AC 115V ~ 60Hz	Poids Net Net Weight	105 lbs

TABLE OF CONTENTS

IMPORTANT SAFETY RULES	3
PARTS & LABOR	4
PREPARATION AND INSTALLATION	5
Preparation.....	5
Installation.....	5
Built-In Instructions.....	5
Electrical Connection.....	6

Extension Cord.....	6
OPERATING THE UNIT.....	6
Initial Use.....	6
Control Panel Lock.....	6
Control Panel for Fridge.....	7
Service and Preservation Temperature.....	7
Temperature Settings.....	7
CARE INSTRUCTIONS.....	7
Operation Anomalies.....	7
Power Failures.....	8
TROUBLESHOOTING GUIDE.....	8

IMPORTANT SAFETY RULES

Before the appliance is used, it must be properly positioned and installed as described in this manual, so read the manual carefully. To reduce the risk of fire, electrical shock or injury when using the appliance, follow basic precaution, including the following:



- Read all instructions before using the fridge.
- Plug into a grounded 3-prong outlet, do not remove grounding prong, do not use an adapter, and do not use an extension cord.
- Replace all panels before operating.
- It is recommended that a separate circuit, serving only your appliance be provided. Use an outlet that cannot be turned off by a switch.
- Never clean appliance parts with flammable fluids. These fumes can create a fire hazard or explosion. And do not store or use gasoline or other flammable vapours and liquids in the vicinity of this or any other appliance. The fumes can create a fire hazard or explosion.
- Before proceeding with cleaning and maintenance operations, make sure the power line of the unit is disconnected.
- Do not connect or disconnect the electric plug when your hands are wet.
- Unplug the appliance or disconnect power before cleaning or servicing. Failure to do so can result in electrical shock or death.
- Do not attempt to repair or replace any part of your appliance unless it is specifically recommended in this material. All other servicing should be referred to a qualified technician.
- To Prevent A Child From Being Entrapped, Keep Out Of Reach Of Children And Not In The Vicinity Of fridge.
- Before you throw away your old fridge, take off the door but leave the shelves in place so that children may not easily climb inside.
- Never allow children to operate, play with, or crawl inside the appliance.



- To ensure proper ventilation for your appliance, the front of the unit must be completely unobstructed. Choose a well-ventilated area with temperatures above 60°F (16°C) and below 90°F (32°C). This unit must be installed in an area protected from the element, such as wind, rain, water spray or drips.
- The appliance should not be located next to ovens, grills or other sources of high heat.
- The appliance must be installed with all electrical, water and drain connections in accordance with state and local codes. A standard electrical supply (115 V AC only, 60 Hz), properly grounded in accordance with the National Electrical Code and local codes and ordinances is required.
- Do not kink or pinch the power supply cord of appliance.

- It is important for the appliance to be levelled in order to work properly. You may need to make several adjustments to level it.
- Do not use solvent-based cleaning agents or abrasives on the interior. These cleaners may damage or discolour the interior.
- Do not use this appliance for other than its intended purpose.
-



FLAMMABLE REFRIGERANT GAS

For your safety observe the following recommendations.

- This appliance contains a small quantity of R600a refrigerant which is environmentally friendly, but flammable. It does not damage the ozone layer, nor does it increase the greenhouse effect.
- During transportation and installation, ensure that the tubing of the refrigerant circuit is not damaged.
- when handling, moving and use of the refrigerator or freezer to avoid either damaging the refrigerant tubing or increasing the risk of a leak.
- Avoid using or manipulating sharp objects near by the appliances.
- Leaking refrigerant can ignite and may damage the eyes.
- In the event any damage does occur, avoid exposure to open fires and any device which creates a spark. Disconnect the appliance from the mains power.
- Thoroughly ventilate the room in which the appliance is located for several minutes.
- Notify Customer Service for necessary action and advice.
- The room for installing the appliance must be at least 1 cubic metre per 8 grams of refrigerant. The refrigerant quantity contained in this appliance is listed above in grams; it is also noted on the Rating Plate of the appliance.

PARTS AND FEATURES

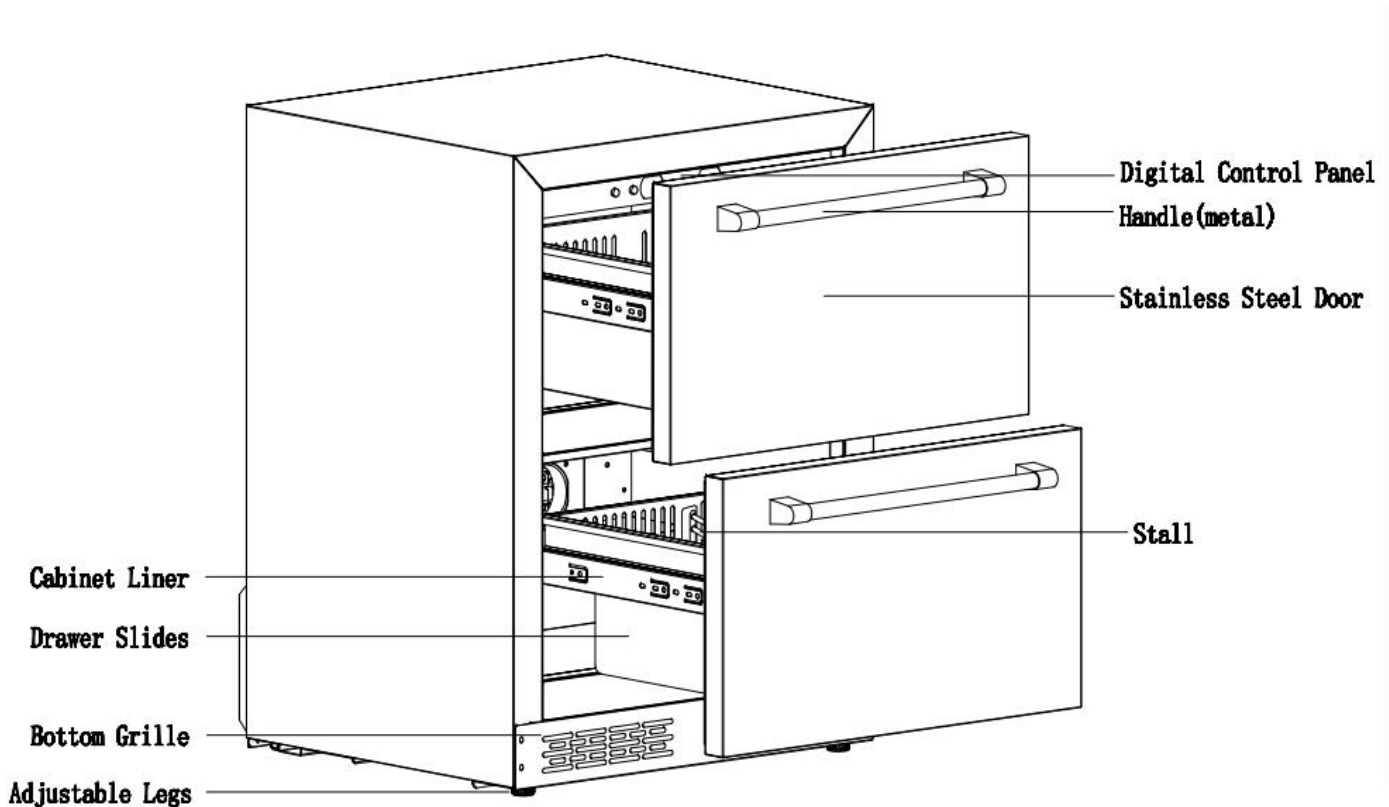
BC/BD/BCD series



BJ series

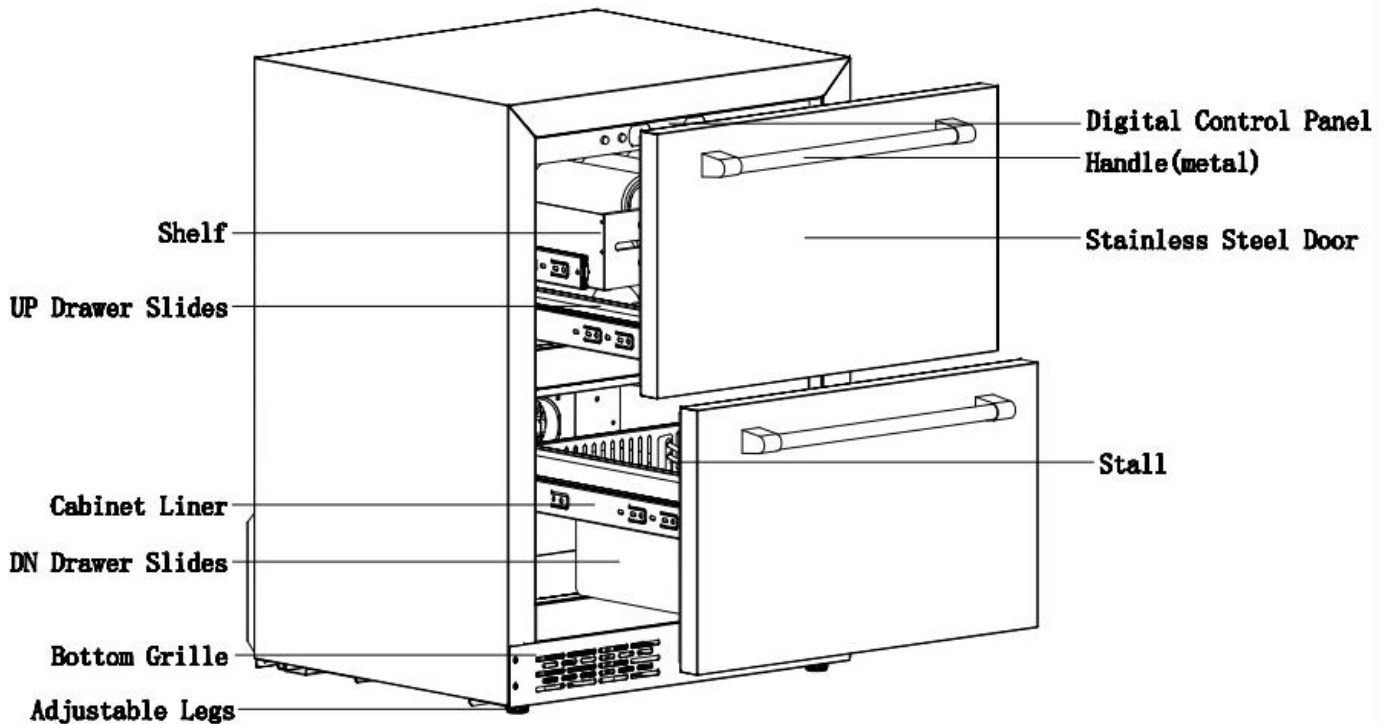

PREPARATION AND INSTALLATION

Preparation

- Allow 24 hours before switching on the fridge. During this time we recommend that you leave the door open to clear any residual odors.
- The location you have selected for your fridge should:
 - Be unencumbered and well ventilated
 - Be well away from any heat source and direct sunlight
 - Not be too damp (laundry, pantry, bathroom etc.)
 - Have a flat floor
 - Have a standard and reliable electricity supply (standard socket to country standards, linked to the ground), it is not recommended to use a multi-socket or extension lead
 - Have a surge protector fitted to the electrical outlet
 - Away from the microwave oven. Certain microwave ovens do not have wave interference shield. When placed within 1 meter vicinity of the wine cabinet, they may affect the operation of the fridge.
 - Avoid locating the unit in moist areas, like a garage.
- The unit should be placed where the ambient temperature is proper. If the temperature is above or below this range, it will affect the performance of the unit. Placing in cold or hot temperature conditions may cause cellar's temperatures fluctuating, and it will not reach the ideal one.

Installation

- Read the instruction manual.
- Unpack and remove all of the protection and adhesive strips from the packaging around and inside the fridge.
- The fridge must be positioned such that the plug is accessible. Release the power cord. Move your fridge to its final location. The fridge should be installed in a suitable place where the compressor will not be subject to physical contact.
- Leveling your fridge: Units must be leveled before loading your drinks. The unit is equipped with 4 adjustable feet to facilitate easy leveling. It's recommended that you tighten the back feet to the maximum and adjust the front feet to level the unit.

Built-in Instructions

- “built-in” fridges and beverage centers are front venting but are not designed to be fully integrated behind a joinery door.
- Please follow the installation diagram when installing a built-in unit. No less than the minimum installation dimension or it will affect the venting of fridge.

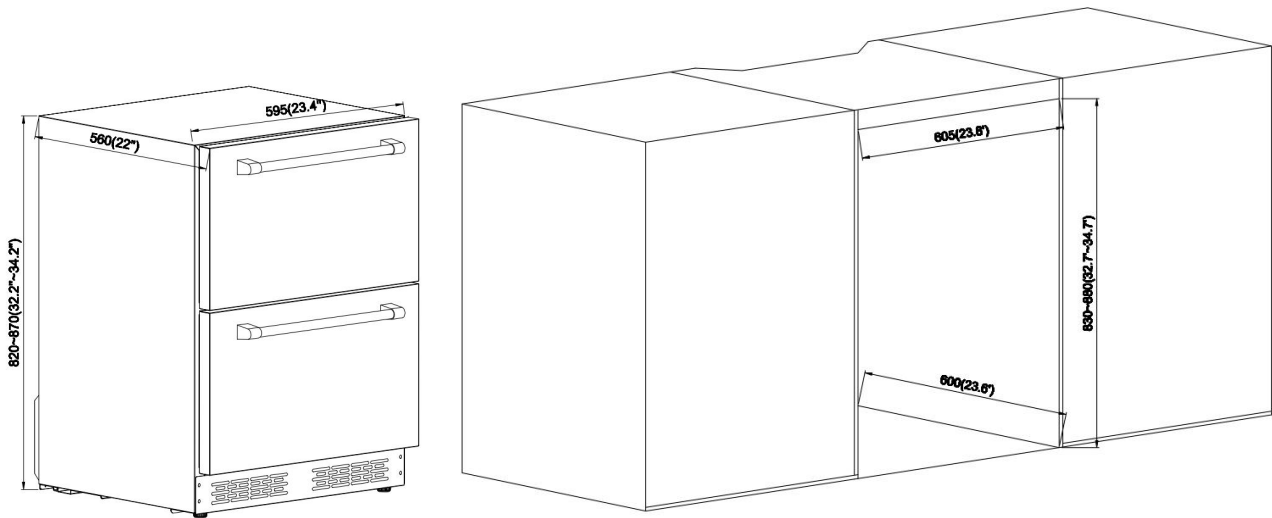

- built-in units draw air from right of ventilation frame and expel through left of ventilation frame under the front door.
- “built-in” fridges and beverage centers have a power switch located on the control panel so power point location is not critical.
- The unit requires a standard 120 volt power point.
- The power cord is 1 m in length and is fixed on the right side at the back when looking from front of fridge.
- As with most appliances of today, the fridge has sensitive electronic components which are susceptible to damage through lightning and electricity supply faults. It is therefore advised to use a power surge protector to avoid problems of this nature.
- Air vent on door must be provided for any built-in wine unit when a wood door is installed in front of the unit.

Electrical Connection

Improper use of the grounded plug can result in the risk of electrical shock. If the power cord is damaged, have it replaced by an authorized service center.

This appliance should be properly grounded for your safety. The power cord of this appliance is equipped with a three-prong plug which mates with standard three prong wall outlets to minimize the possibility of electrical shock.

Do not under any circumstances cut or remove the third ground prong from the power cord supplied. For personal safety, this appliance must be properly grounded.

This appliance requires a standard 115/120 Volt AC ~/60Hz electrical ground outlet with three-prong. Have the wall outlet and circuit checked by a qualified electrician to make sure the outlet is properly grounded. When a standard 2-prong wall outlet is encountered, it is your responsibility and obligation to have it replaced with a properly grounded 3-prong wall outlet. The cord should be secured behind the appliance and not left exposed or dangling to prevent accidental injury.

The appliance should always be plugged into its own individual electrical outlet which has a voltage rating that matches the rating label on the appliance. This provides the best performance and also prevent overloading house wiring circuits that could cause a fire hazard from overheated. Never unplug the appliance by pulling the power cord. Always grip the plug firmly and pull straight out from the receptacle. Repair or replace immediately all power cords that have become frayed or otherwise damaged. Do not use a cord that shows cracks or abrasion damage along its length or at either end. When moving the appliance, be careful not to damage the power cord.

Extension Cord

Because of potential safety hazards under certain conditions, it is strongly recommended that you do not use an extension cord with this appliance. However, if you must use an extension cord it is absolutely necessary that it be a

UL/CUL-Listed, 3-wire grounding type appliance extension cord having a grounding type plug and outlet and that the electrical rating of the cord be 115 volts and at least 10 amperes.

OPERATING THE UNIT

Initial Use

Plug in and switch on the fridge by pressing on the power button **for a few seconds**.

When you use the fridge for the first time (or restart the fridge after having it shut off for a long time), there will be a few degrees variance between the temperature you have selected and the one indicated on the LED readout. This is normal and it is due to the length of the activation time. Once the fridge is running for a few hours everything will stabilize.

IMPORTANT: If the unit is unplugged, power is lost, or turned off, wait 3 to 5 minutes before restarting the unit. The fridge will not start if you attempt to restart before this time delay.

Control Panel Lock

The unit is equipped with an automatic control panel lock function. This function will prevent any unwanted changes to your temperature or power settings. The lock function will activate automatically 5 seconds after the last time a button is pushed on the control panel.

To unlock the control panel lock, press and hold both the **UP** and **DOWN** buttons for 5 seconds the control panel will beep and blink once indicating that the control panel is active and the settings can be changed. You must unlock the control panel every time you want to set the temperature, change the display setting ($^{\circ}\text{F}/^{\circ}\text{C}$) turn on or off the light and to power off the fridge.

Control panel for Fridge

Single Zone

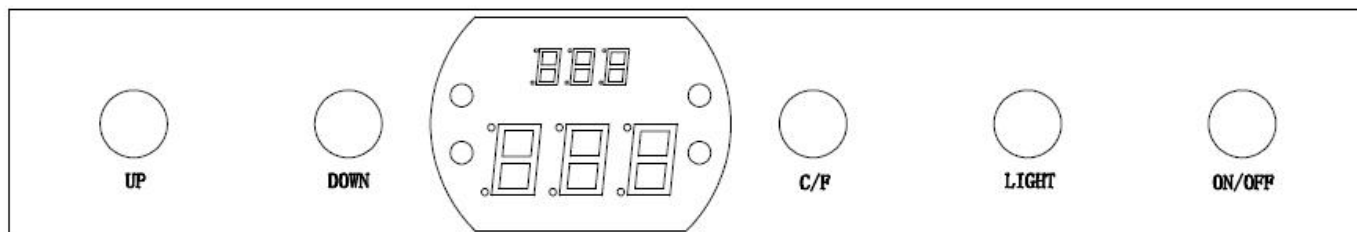

Double Zone

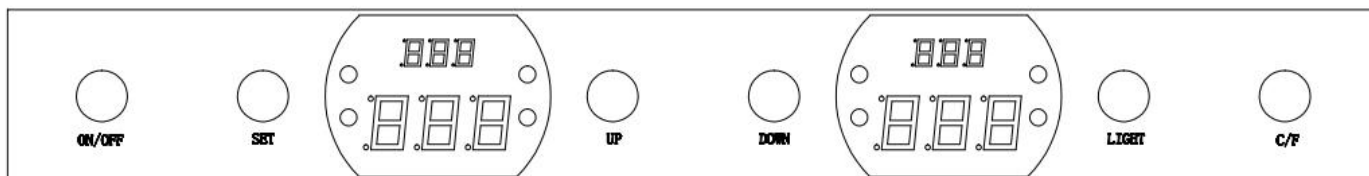

- **POWER:ON/OFF**
- **LIGHT:** light on/light off
- **SET TEMP: UP/DOWN**
- $^{\circ}\text{C}/^{\circ}\text{F}$: Celsius/ Fahrenheit switch

To control the temperature: The up digital chamber indicates the setting temp, ranging from $1^{\circ}\text{C}\sim 22^{\circ}\text{C}$ ($34^{\circ}\text{F}\sim 72^{\circ}\text{F}$) (refrigerator); ranging from $-18^{\circ}\text{C}\sim 1^{\circ}\text{C}$ ($-1^{\circ}\text{F}\sim 34^{\circ}\text{F}$) (freezer), when temperature is set between $1^{\circ}\text{C}\sim 22^{\circ}\text{C}$ or $-18^{\circ}\text{C}\sim 1^{\circ}\text{C}$, the indicator corresponding the chamber on the up side will flash. The digital tube on the down chamber indicates the actual temp inside the fridge, ranging from $0\sim 37^{\circ}\text{C}$ ($32^{\circ}\text{F}\sim 99^{\circ}\text{F}$)(refrigerator); ranging from $-18\sim 37^{\circ}\text{C}$ ($-1^{\circ}\text{F}\sim 99^{\circ}\text{F}$)(freezer).

The user can re-set temp inside the fridge based on actual requirement, after start working, the fridge will keep on refrigerating till it reaches the set temp, and work around setting temp within range of $\pm 2^{\circ}$. Under the circumstances of power stop or cutting in the process of normal operation, the last setting figure can be automatically memorized by the fridge.

Light ON/OFF: There is a light in the fridge. The light is controlled by two door pressure switches. When both drawers are closed, the light goes off automatically, and when either drawer is pulled out, the light goes on.

To change the temperature display: The temperature displayed can be in Fahrenheit or Celsius. Press the °C/°F button to switch between °F and °C.

Service and Preservation Temperature

It is recommended you install the fridge in a place where the ambient temperature is between 1°C-32°C (34°F-89°F). If the ambient temperature is above or below recommended temperatures, the performance of the unit may be affected. For example, placing your fridge in extreme cold or hot conditions may cause interior temperatures to fluctuate. The range of -18°C-22°C (-1°F-72°F) may not be reached.

Temperature Settings

IMPORTANT: The LED displays by default the actual internal air temperature.

The temperature settings are pre-set at the factory as follows. In the event of a power interruption, all previous temperature settings are automatically erased and it will revert to the pre-set temperature settings. The electrical board of all models comes with memory function.

It is important to understand that there is a difference between the air temperature inside the fridge and the actual temperature of the drinks: You will need to wait approximately 3 hours before noticing the effects of temperature adjustment due to the critical mass within a full fridge.

CARE INSTRUCTIONS

Operation Anomalies

Ensure that there is power to the electrical supply plug by connecting another electrical appliance to it. Check fuse, if any. Make sure that the door is closed properly.

If the unit appears to be malfunctioning, unplug it and contact your after sales service. Any intervention on the cold circuit should be performed by a refrigeration technician who should carry out an inspection of the circuit sealing system. Similarly, any intervention on the electrical circuit should be performed by a qualified electrician.

IMPORTANT: Any intervention performed by a non-authorized technician by will lead to the warranty being considered as null and void.

Power Failures

In the event of a power interruption, all previous temperature settings are automatically preservation and it will revert to a pre-set temperature setting.

TROUBLESHOOTING GUIDE

You can solve many common fridge problems easily, saving you the cost of a possible service call. Try the suggestions below to see if you can solve the problem before calling the servicer.

PROBLEM	CAUSE POSSIBLE
The unit does not operate.	Not plugged in. The appliance is turned off. The circuit breaker tripped or the fuse is broken.
The unit is not cold enough.	Check the temperature control setting. External environment may require a higher setting.

	<p>The drawer door is opened too often. The drawer door is not closed completely. The drawer door gasket does not seal properly.</p>
Turns on and off frequently.	<p>The room temperature is hotter than normal. A large amount of contents has been added to the fridge. The drawer door is opened too often. The drawer door is not closed completely. The temperature control is not set correctly. The drawer door gasket does not seal properly.</p>
The light does not work.	<p>Not plugged in. The circuit breaker tripped or a blown fuse. The LED Light is out of order. The door pressure switch is out of order.</p>
Vibrations.	<p>Check to assure that the unit is level.</p>
The unit seems to make too much noise.	<p>The rattling noise may come from the flow of the refrigerant, which is normal. As each cycle ends, you may hear gurgling sounds caused by the flow of refrigerant in your fridge. Contraction and expansion of the inside walls may cause popping and crackling noises. The unit is not level.</p>
The door will not close properly.	<p>The unit is not level. The door Drawer slide screw loose. The Drawer slide inside debris stuck. The drawer slide track is broken.</p>