

STEP 3

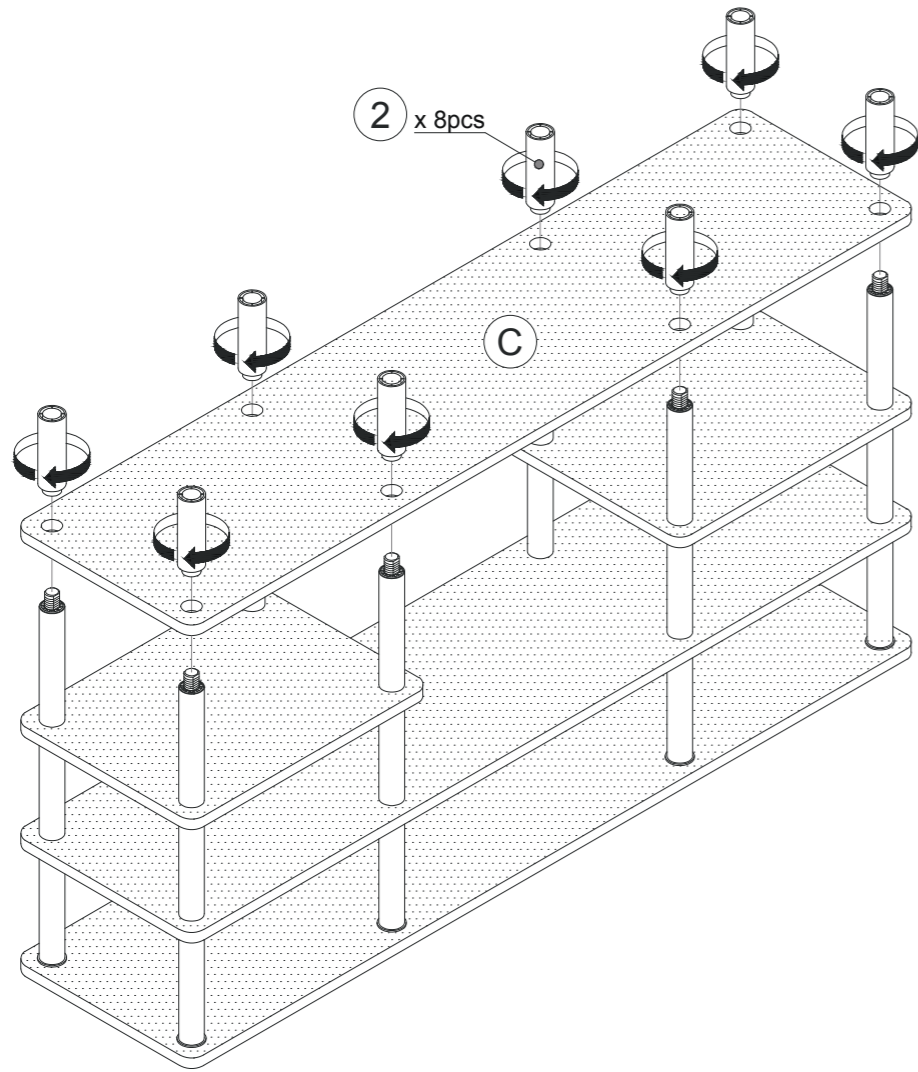

Recommended Maximum Weight

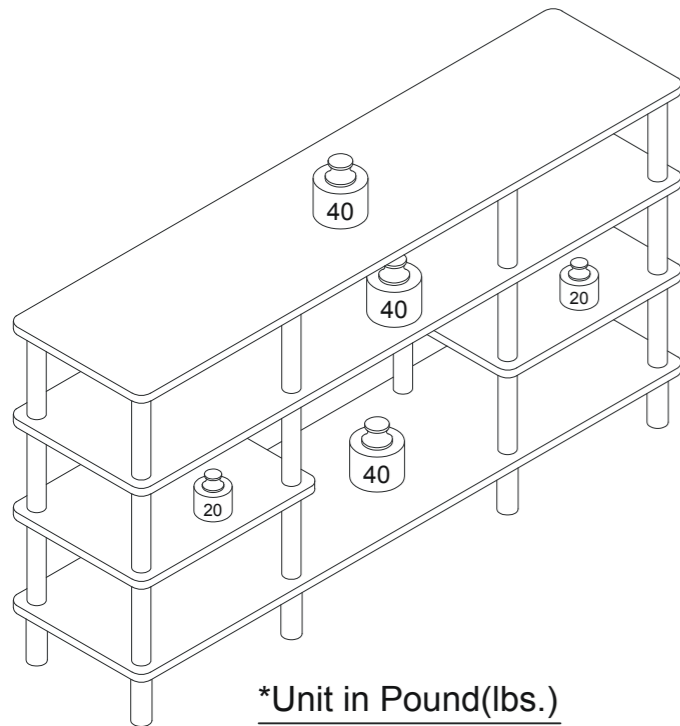

WARNING:

>This unit has been designed to support the maximum loads shown. Exceeding these load limits could cause sagging, instability, product collapse, and/or serious injury.

>DO NOT allow children to climb on unit.

> Put heavier items on lower shelves.

Assembly Instruction

Tier Multipurpose Wide Shelf

00:20

Approx. 20 minutes



Recomm. 1 Person

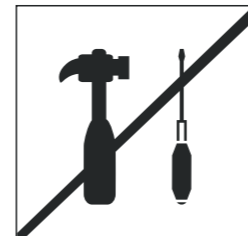

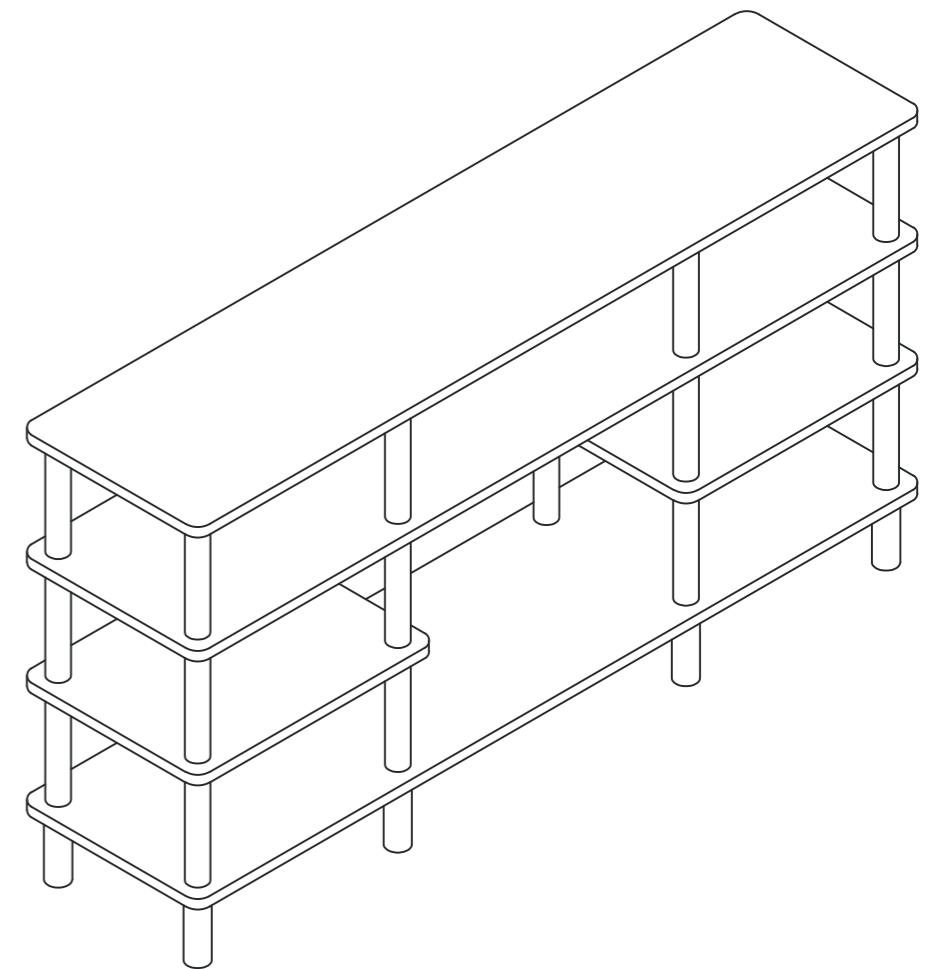

No Tools Required



HARDWARE & PARTS LIST

NO	PARTS LIST	QTY
A	TOP PANEL	1 PC
B	SMALL SHELF PANEL	2 PCS
C	LARGE SHELF PANEL	2 PCS

NO	HARDWARE LIST	QTY
1	SHORT PE TUBE 	24 PCS
2	PE LEG 	8 PCS

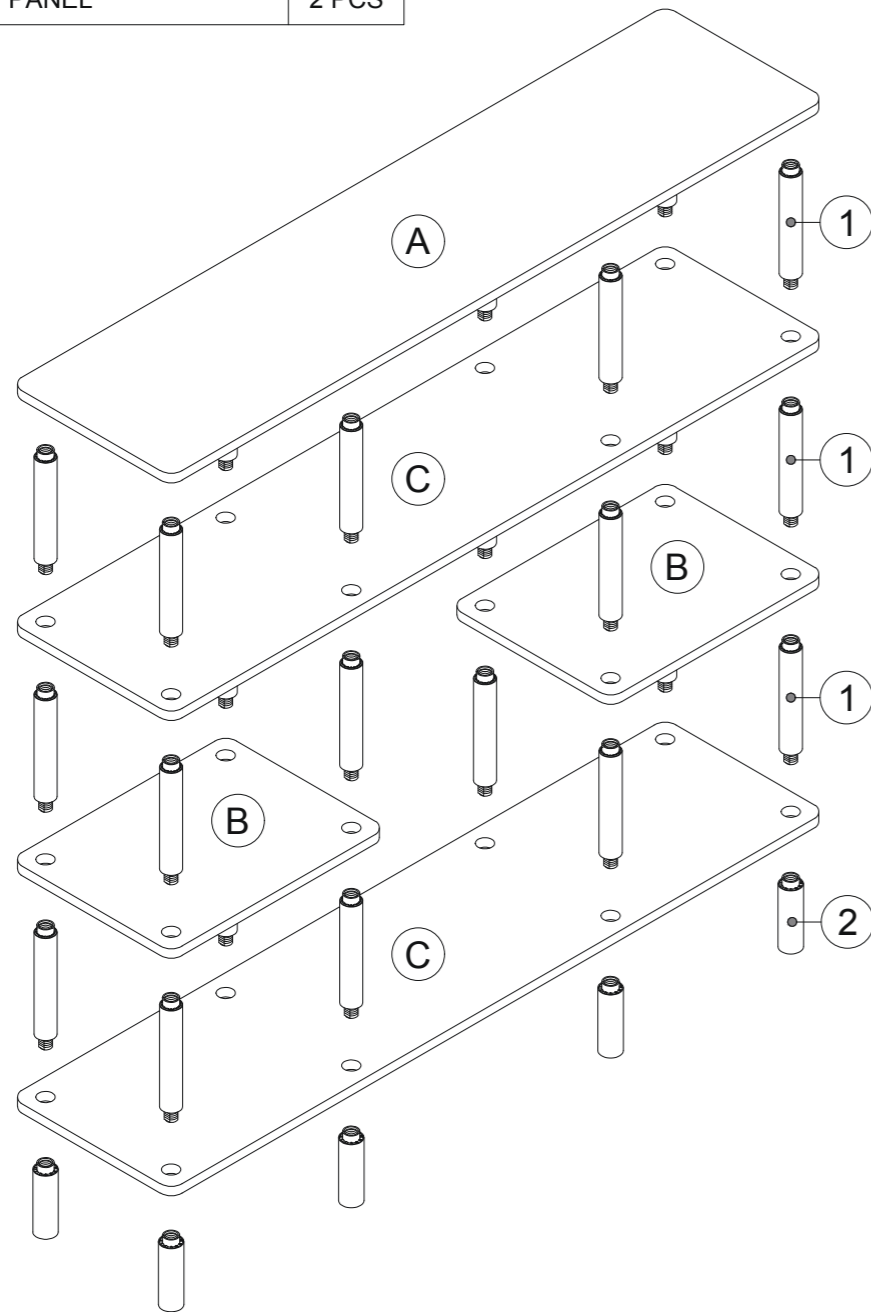

USEFUL HINTS BEFORE YOU START:

1. Read each step carefully before starting.
2. It is important that each step is performed in correct order to avoid difficulties.
3. Identify, sort and count the parts before assembly.
4. Assemble your furniture on packaging cardboard to prevent scratch or damage.
5. Clean the product with mild cleanser using soft damp cloth. Do not use harsh or abrasive cleanser.
6. Using incompatible hardware might cause damage to product.

STEP 1

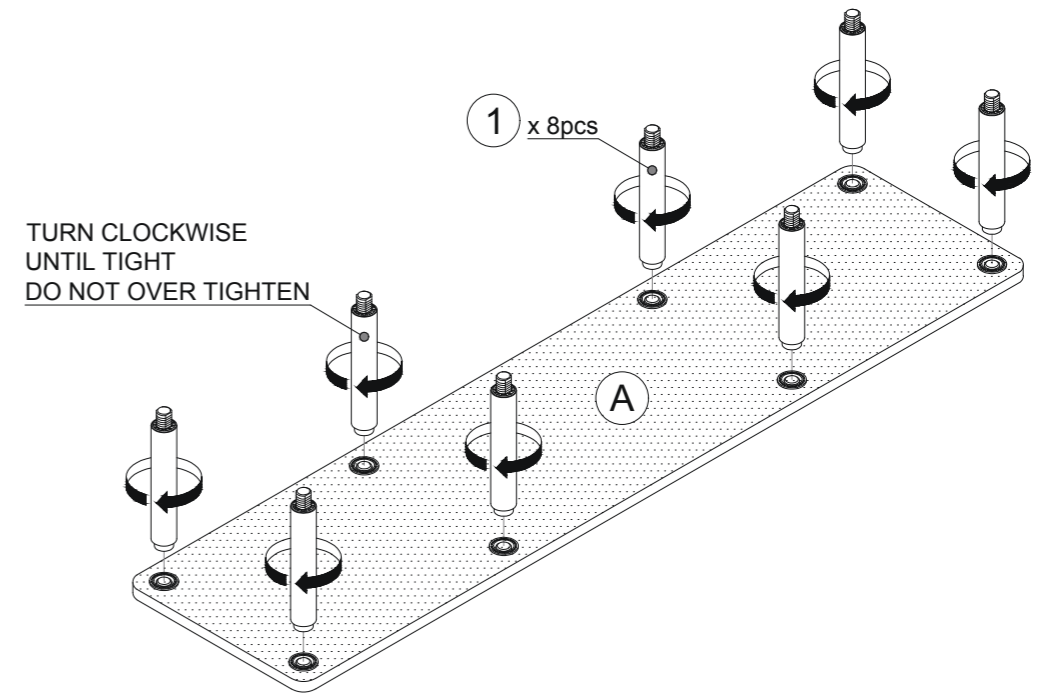

STEP 2

