

ASSEMBLY INSTRUCTIONS

PE Rattan Furniture Set

Thanks for choosing our product. Please kindly check parts listed below and read this manual carefully, then assemble them step by step. Please feel free to contact us for any questions.

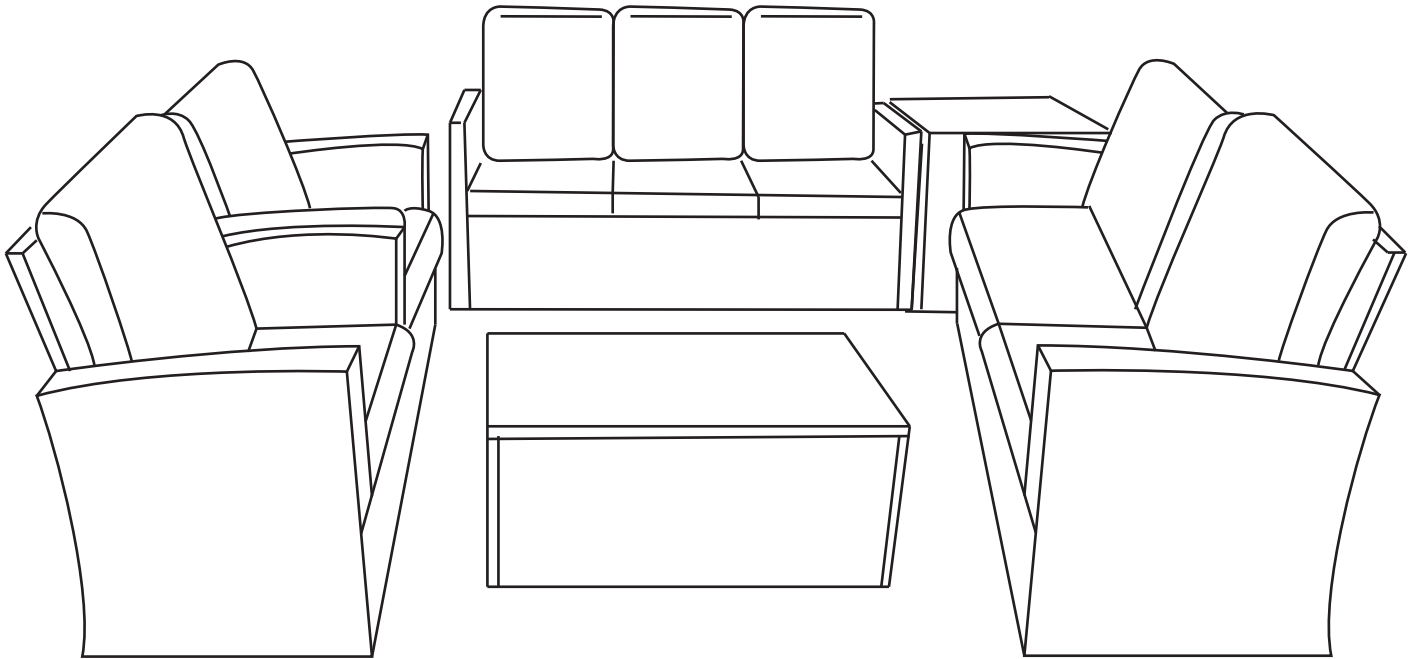

Attention









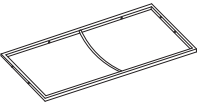

1. THE PE RATTAN FURNITURE SET COMES WITH 3 SEPARATE BOXES AND MAY ARRIVE AT DIFFERENT TIME, PLEASE BE PATIENT! PLEASE CHECK THE PARTS LIST CAREFULLY AND CONTACT US IF THERE IS ANY PROBLEM.

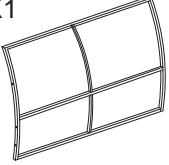
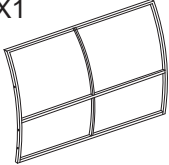
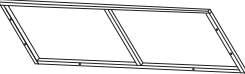
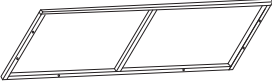
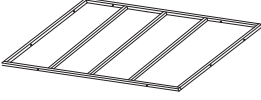
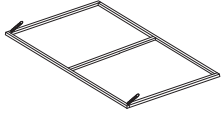
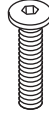
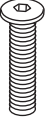
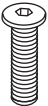
2. Please follow the instruction step by step to complete the installation, finish one part by part. Please contact us if you have any questions.

3. We recommend to use waterproof furniture cover for entire furniture set which better helps you to protect your furniture set outside.

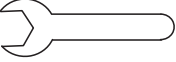
4. Sofa cushion covers can be removed and cleaned. We recommend that 2 person assemble set .

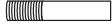
Package A Parts List

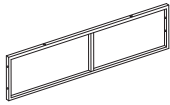
D X2  Seat Panel	E X25  Adjustable Feet Pad	G X1  Backrest Panel	H X1  Backrest Panel	I1 X1  Table Panel
I2 X1  Table Panel	K X1  Table Bottom Panel	L X1  Table Top Panel	Q X61  M6*55 Screw	R X7  M6*35 Screw
R1 X32  M6*30 Screw	S X8  M6*20 Screw	T X2  Allen Key	U X61  Nut	V X2  Wrench
W X166  Washer	X X4  Washer	Y X9  Screw	a1 X1  Table Interior Cover	a2 X1  Storage Interior Cover
Z1 X2  Seat Front Panel				

Package B Parts List

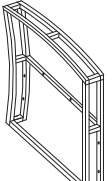
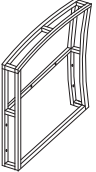
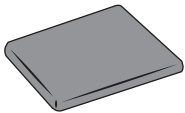
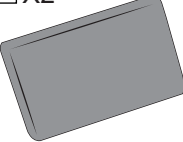
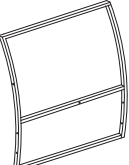
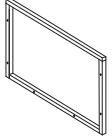



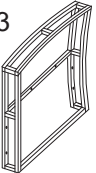
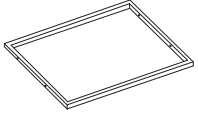
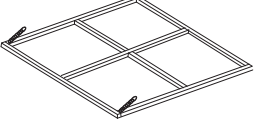
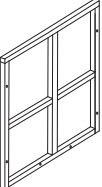
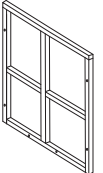
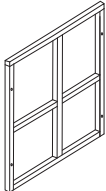
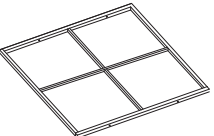
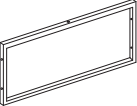
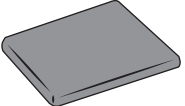
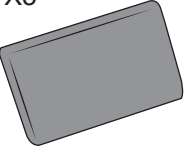

A X4  Right Armrest	B X1  Left Armrest	b1 X5  Seat Cushion	b2 X2  Backrest Cushion	F X3  BackRest Panel	J X2  Table Panel
---	--	---	--	--	---

Package C Parts List

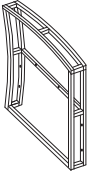
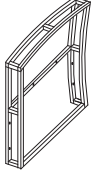
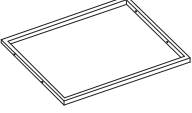
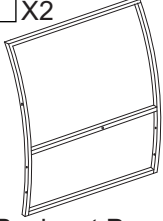
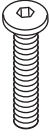
B X3  Left Armrest	C X3  Seat Panel	M X1  Storage Top Panel	N1 X1  Storage Panel	N2 X1  Storage Panel
O X2  Storage Panel	P X1  Storage Bottom Panel	Z X3  Seat Front Panel	b1 X2  Seat Cushion	b2 X5  Backrest Cushion

Single Sofa

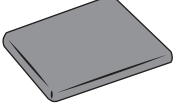
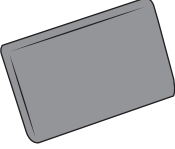
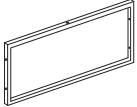
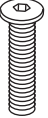
Parts List (Single Sofa Needed)

A X2  Right Armrest	B X2  Left Armrest	C X2  Seat Panel	F X2  Backrest Panel	Q X26  M6*55 Screw	W X54  Washer
U X26  Nut	Y X4  Screw	b1 X2  Seat Cushion	b2 X2  Backrest Cushion	Z X2  Seat Front Panel	R X2  M6*35 Screw
E X8  Adjustable Feet Pad					

STEP 1

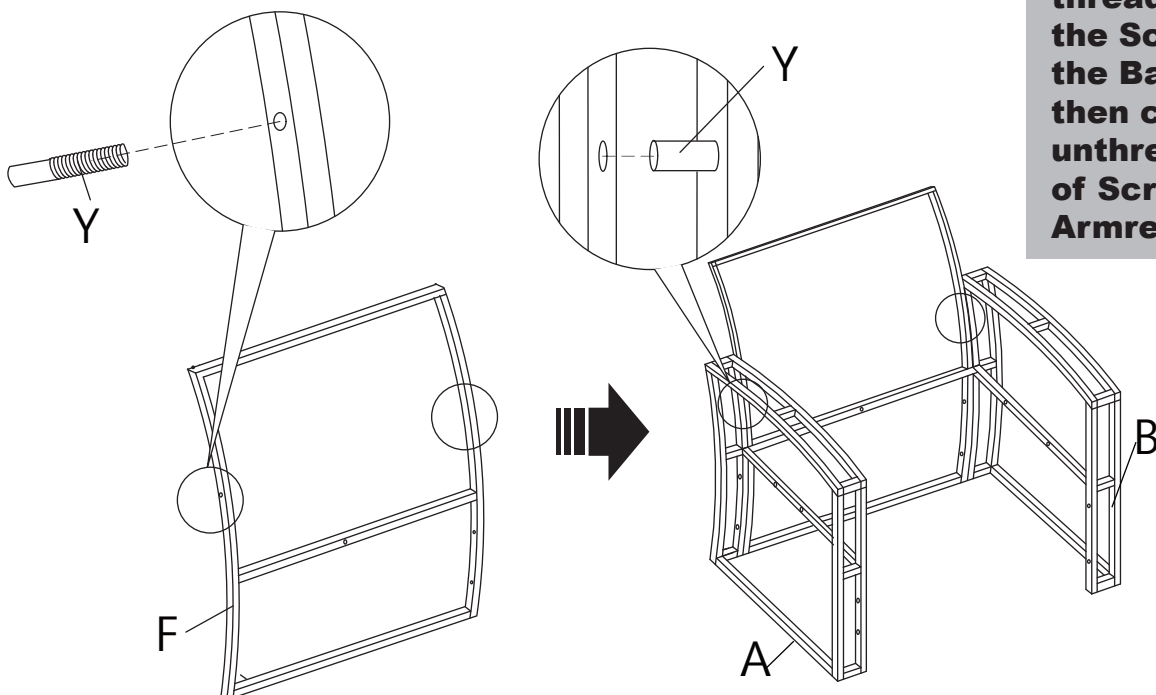

Please insert the threaded section of the Screw Y into the Backrest F and then connect the unthreaded section of Screw Y to the Armrest A.

STEP 2

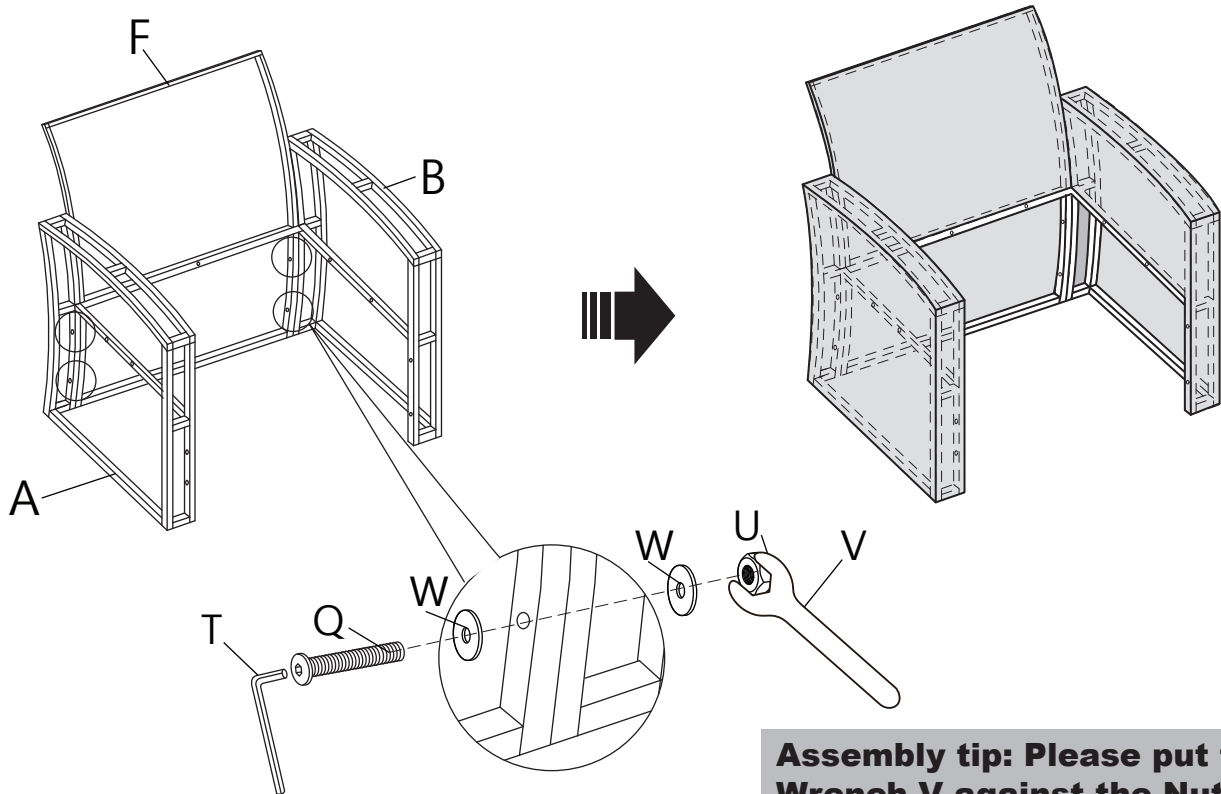





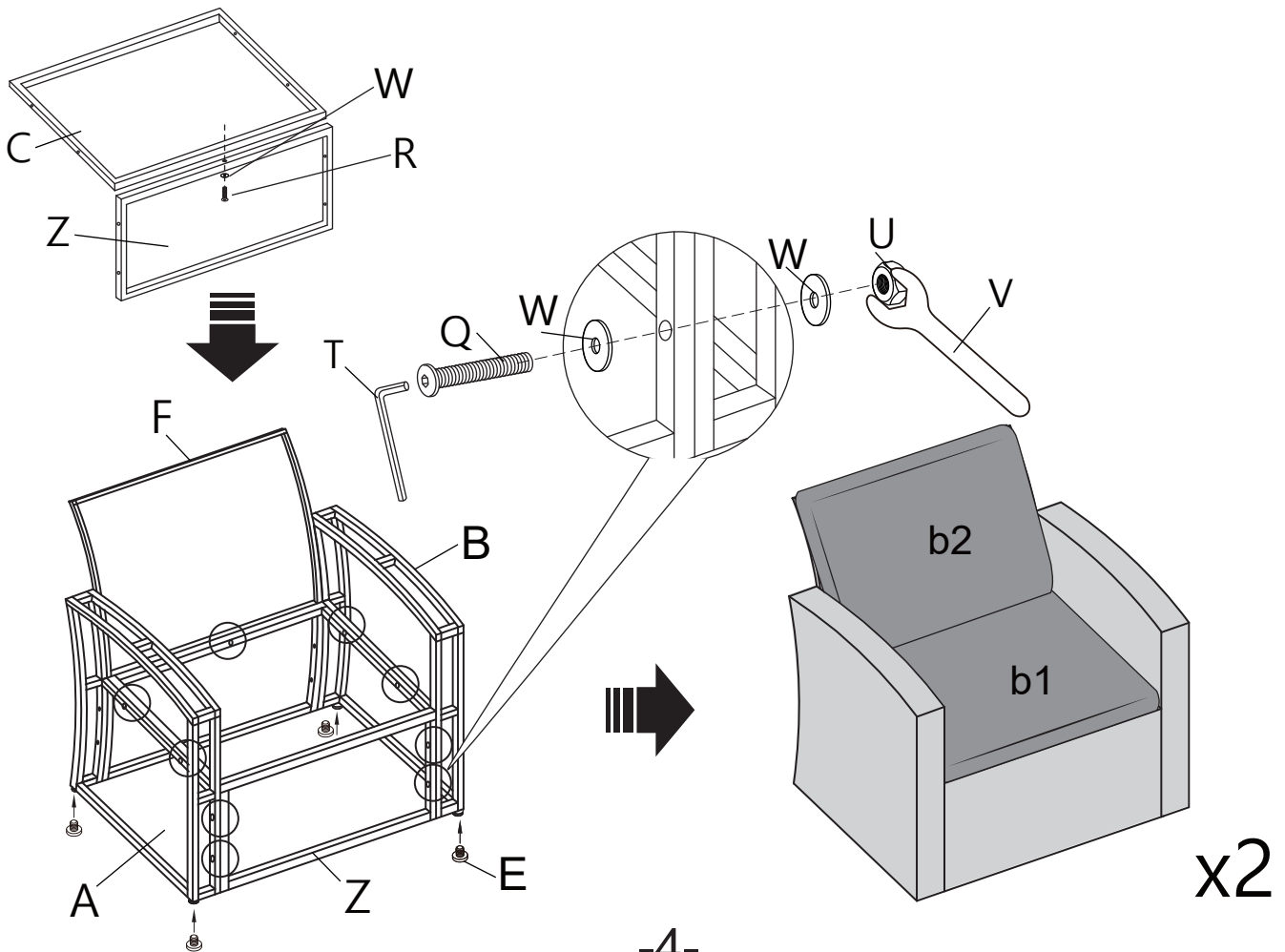

Assembly tip: Please put the Wrench V against the Nut U then rotating Allen Key T to insert the Screw Q.

STEP 3

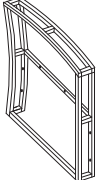
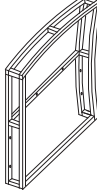
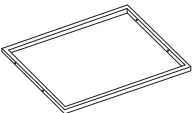
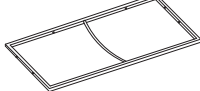
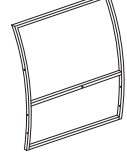
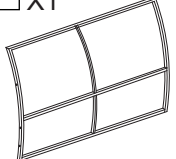
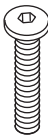

Three person sofa

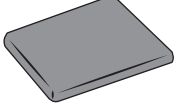
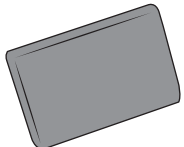
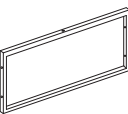
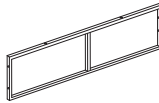
Parts List (Three person Sofa Needed)

A X1  Right Armrest	B X1  Left Armrest	C X1  Seat Panel	D X1  Seat panel	F X1  Backrest Panel	H X1  Backrest Panel
Q X21  M6*55 Screw	W X45  Washer	U X21  Nut	Y X3  Screw	b1 X3  Seat Cushion	b2 X3  Backrest Cushion
Z X1  Seat Front Panel	Z1 X1  Seat Front Panel	R X3  M6*35 Screw	E X9  Adjustable Feet Pad		

STEP 1

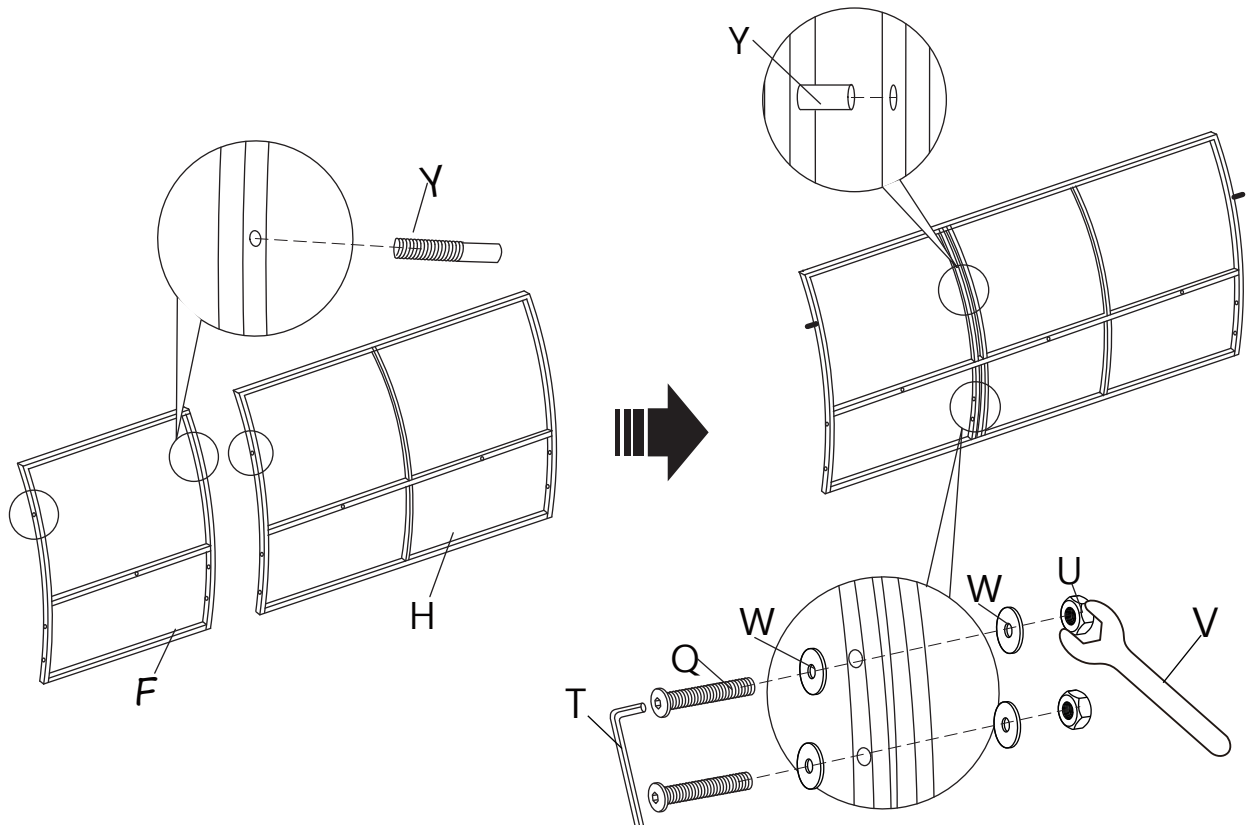

STEP 2

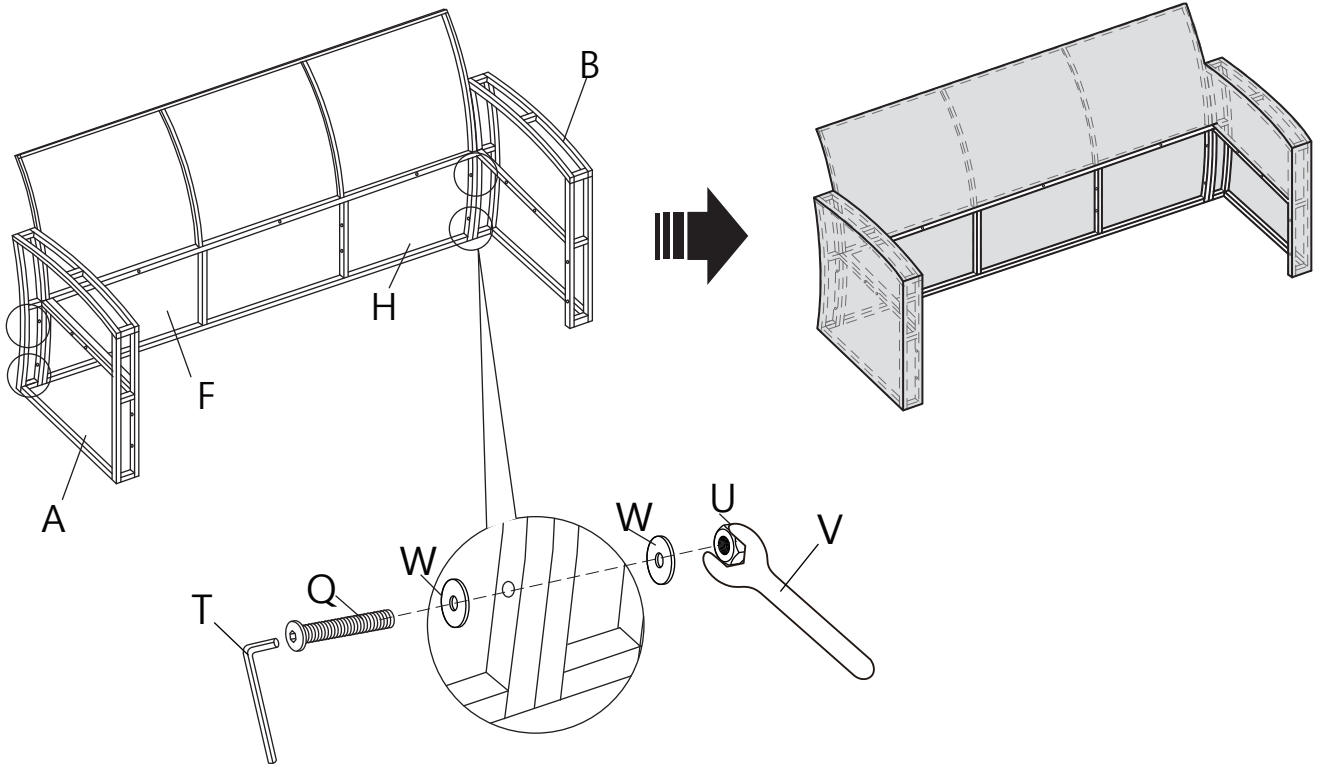



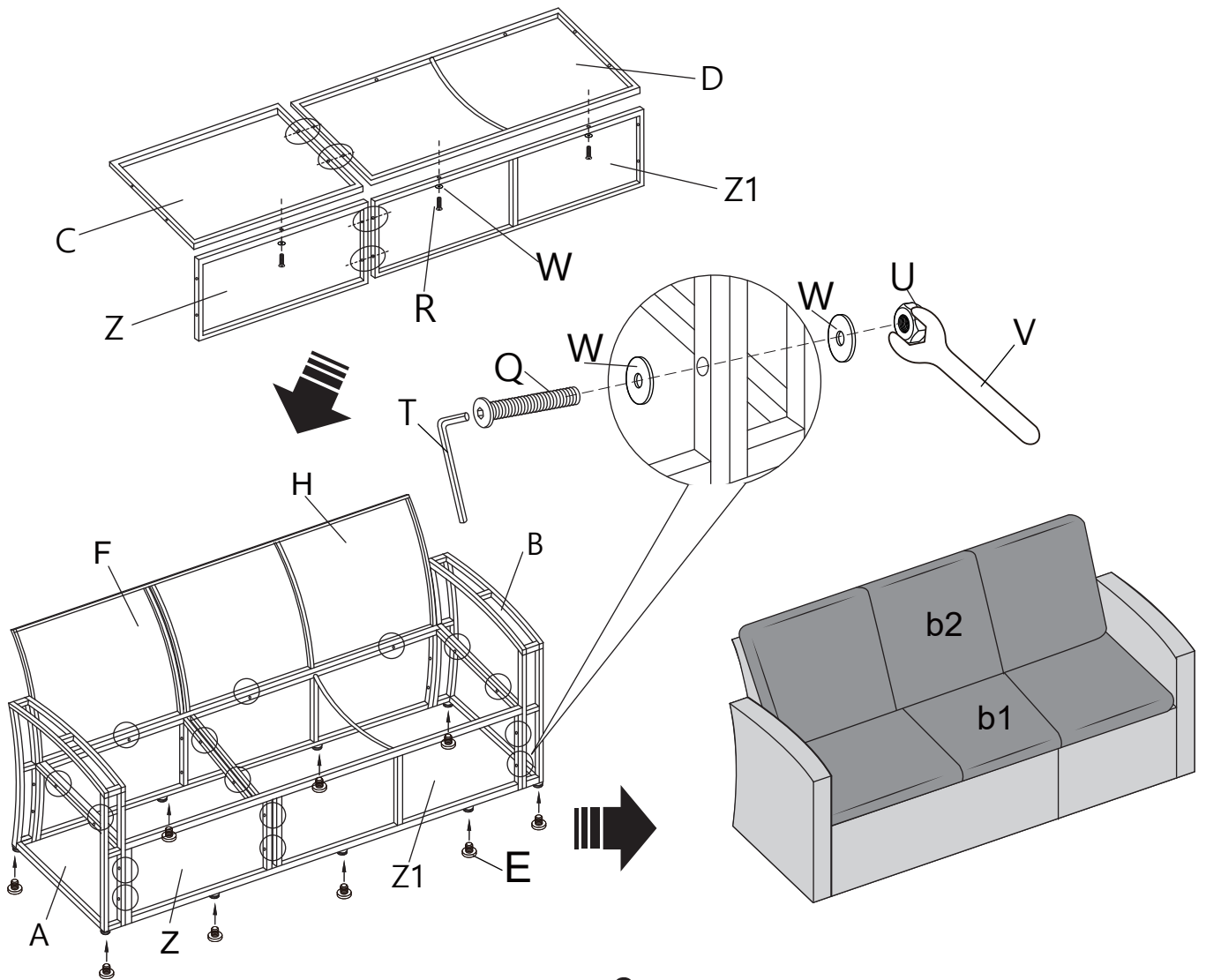



STEP 3

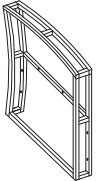
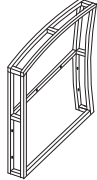
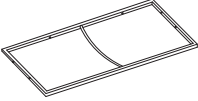
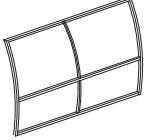
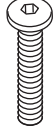

Two person Sofa

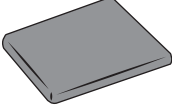
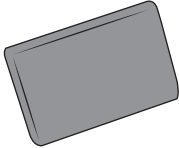
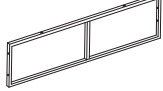
Parts List (Single Sofa Needed)

A X1  Right Armrest	B X1  Left Armrest	D X1  Seat Panel	G X1  Backrest	Q X14  M6*55 Screw	W X30  Washer
U X14  Nut	Y X2  Screw	b1 X2  Seat Cushion	b2 X2  Backrest Cushion	Z1 X1  Seat Front Panel	R X2  M6*35 Screw
E X8  Adjustable Feet Pad					

STEP 1

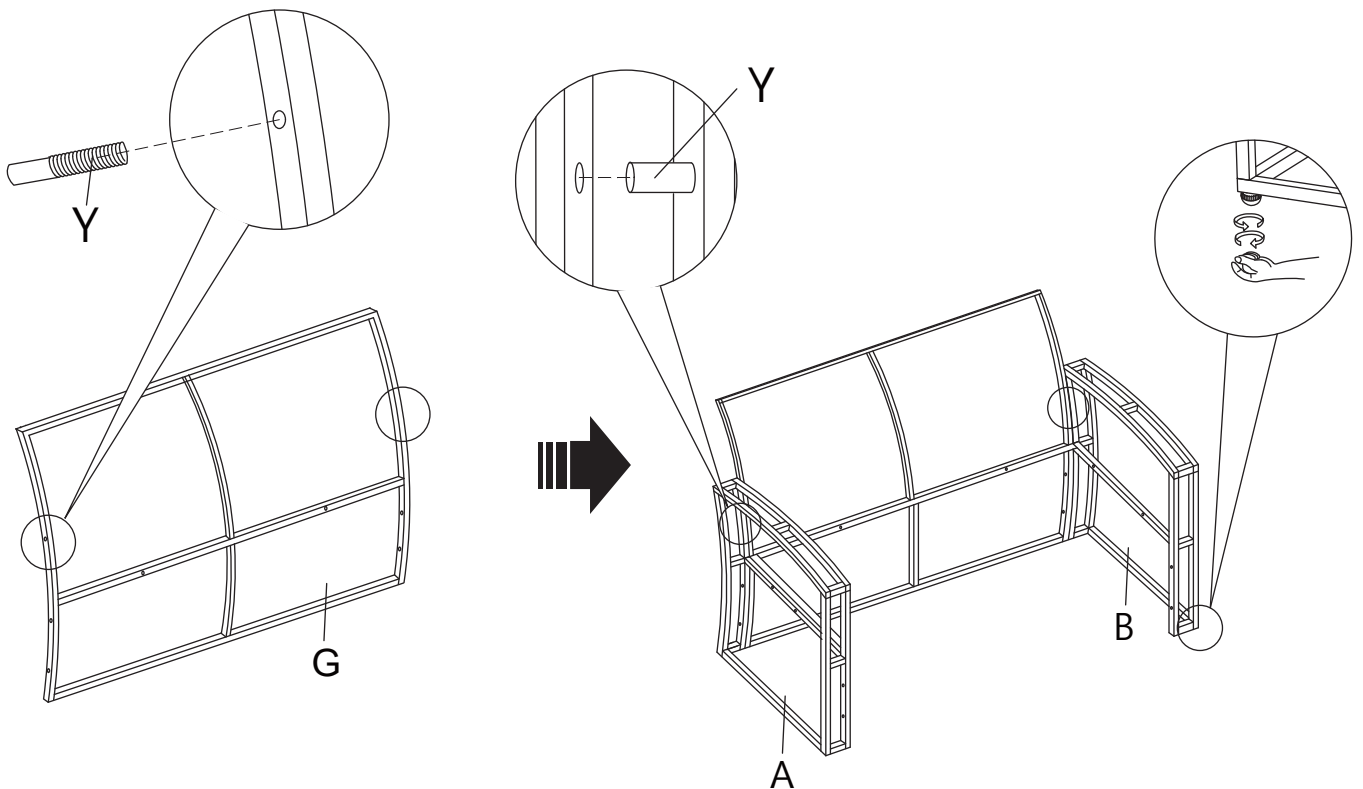

STEP 2

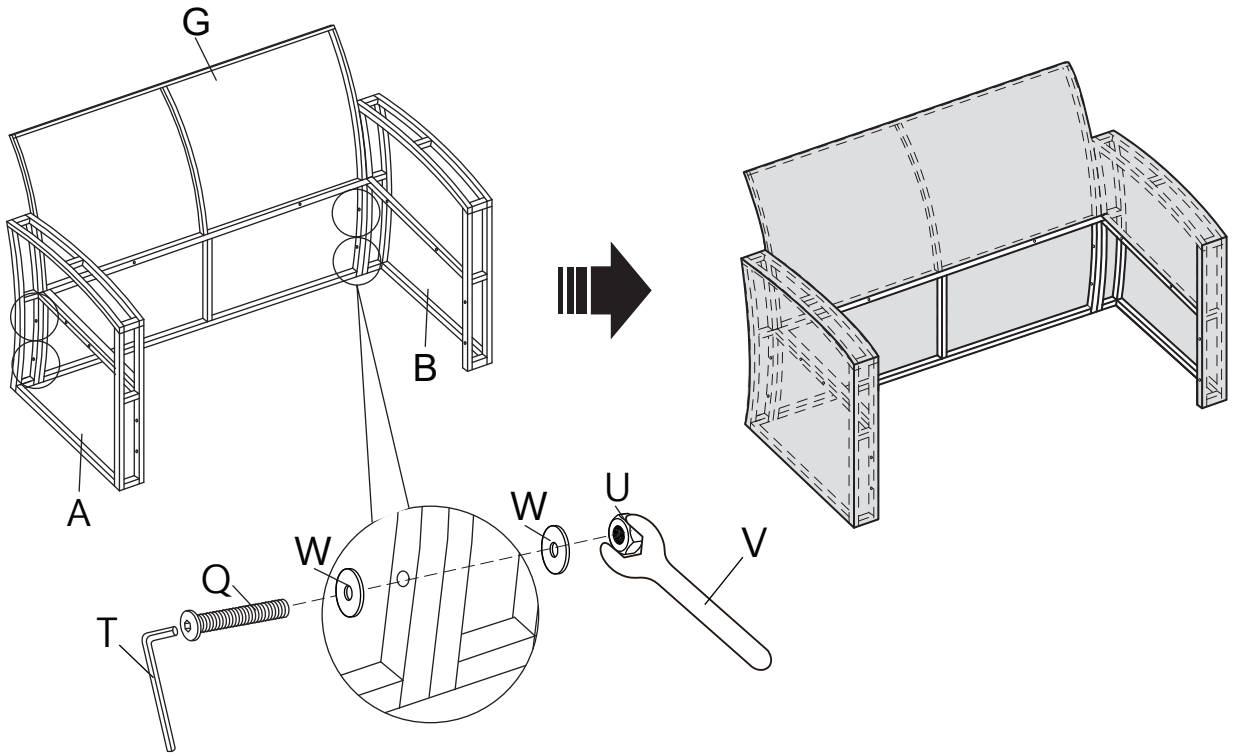



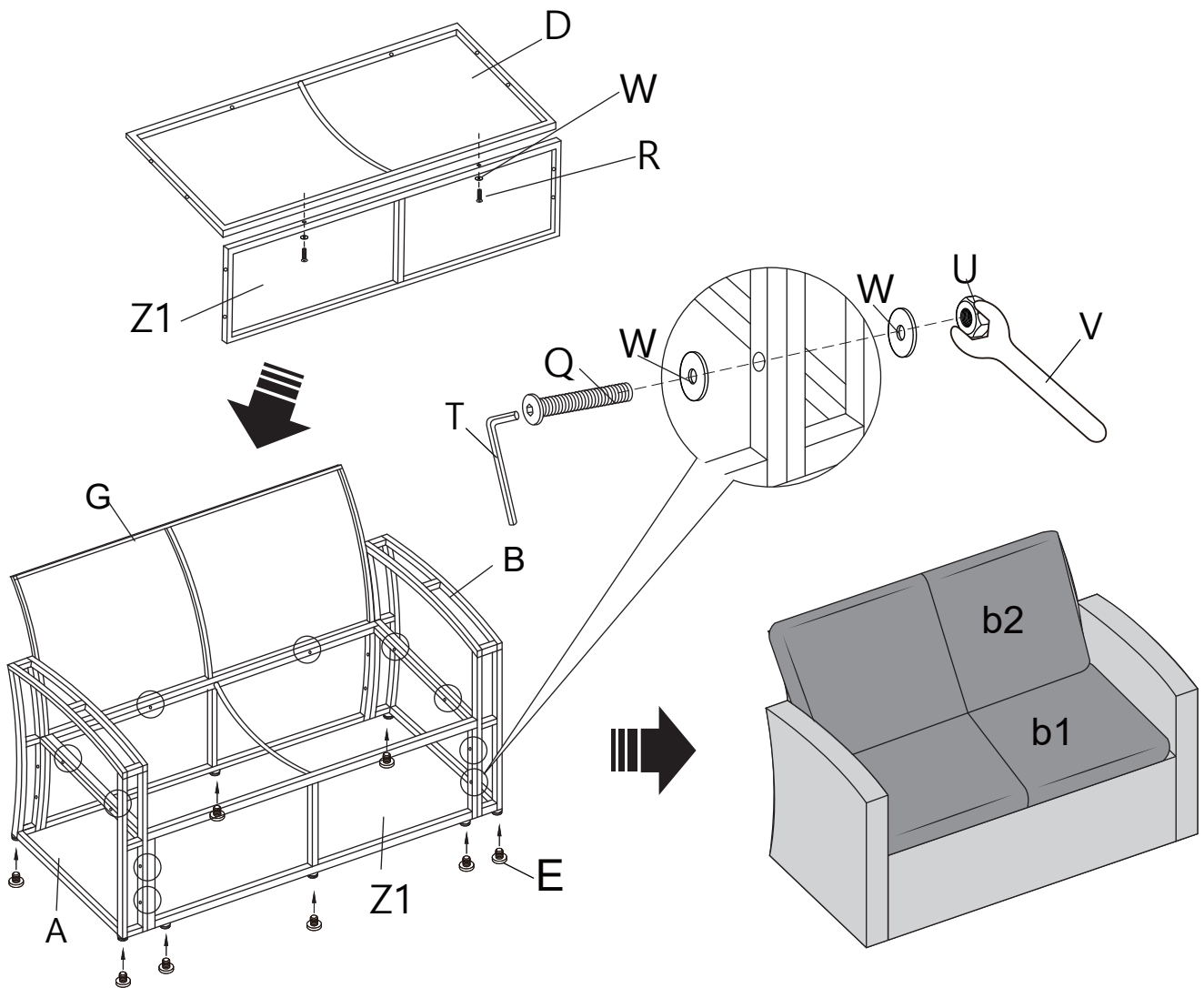



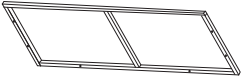

STEP 3

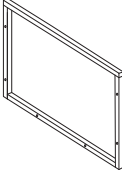
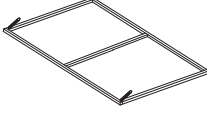
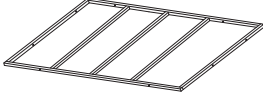

Coffee Table

Parts List (Coffee Table Needed)

I1 X1  Table Panel	I2 X1  Table Panel	J X2  Table Panel	L X1  Table Top Panel	K X1  Table Bottom Panel
R1 X16  M6*30 Screw	S X4  M6*20 Screw	X X2  Washer	W X18  Washer	a1 X1  Storage Interior Cover

STEP 1

Please note : All panels with velcro face up.

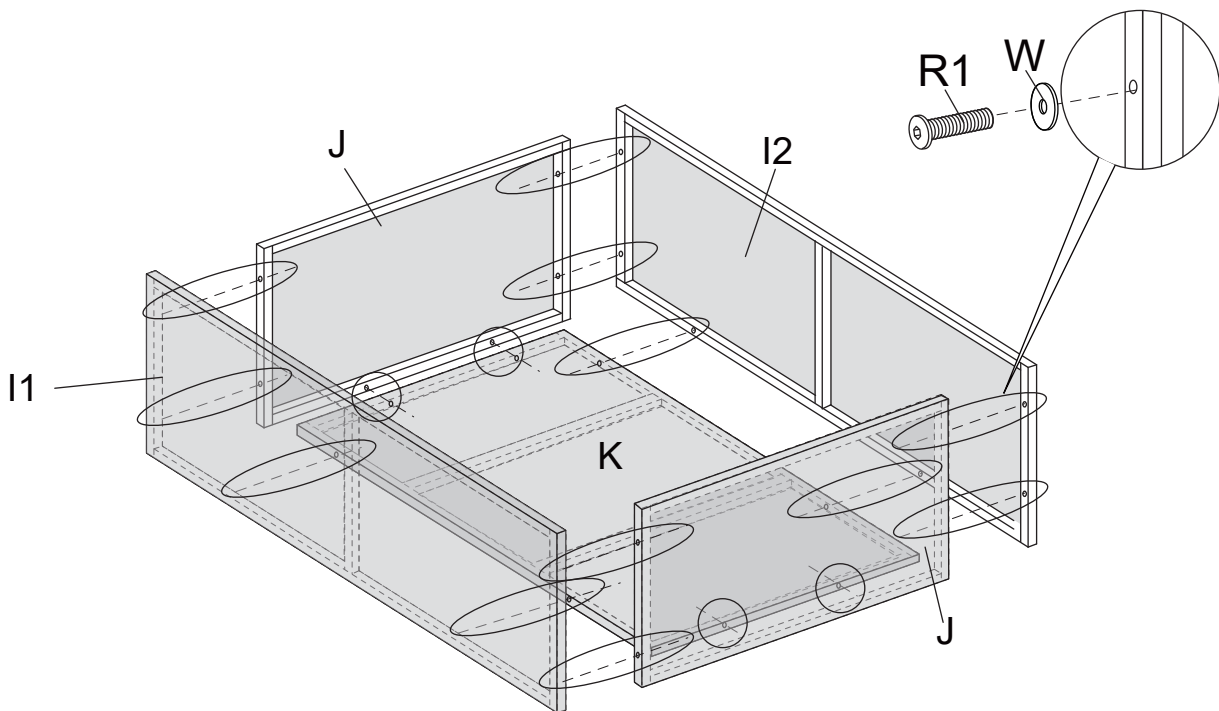

STEP 2

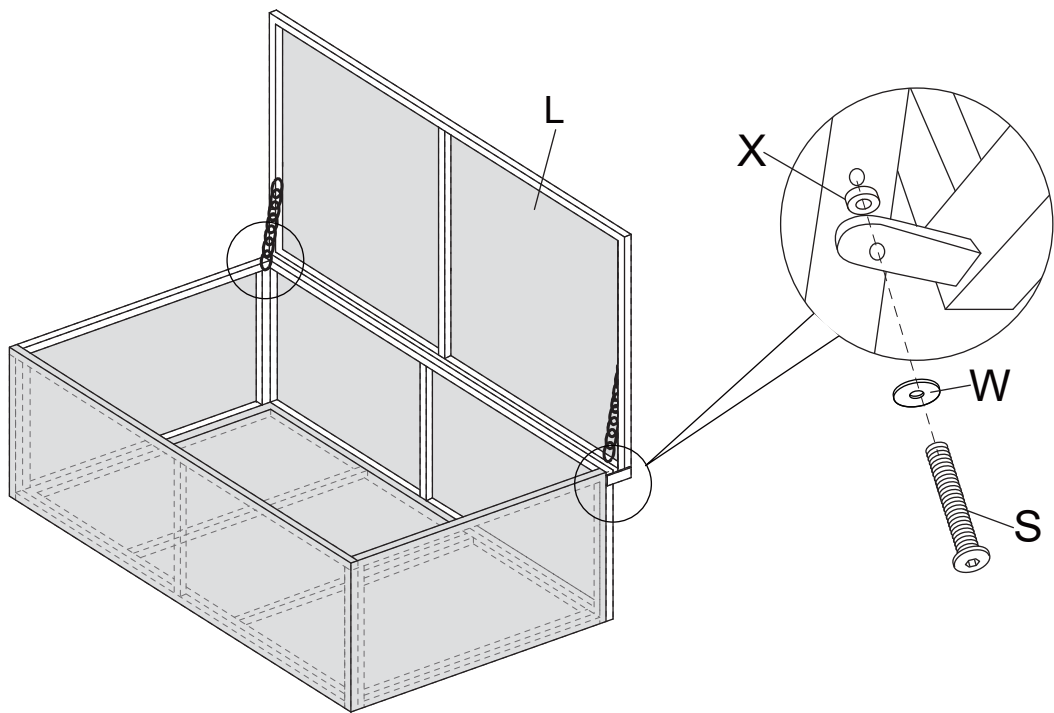



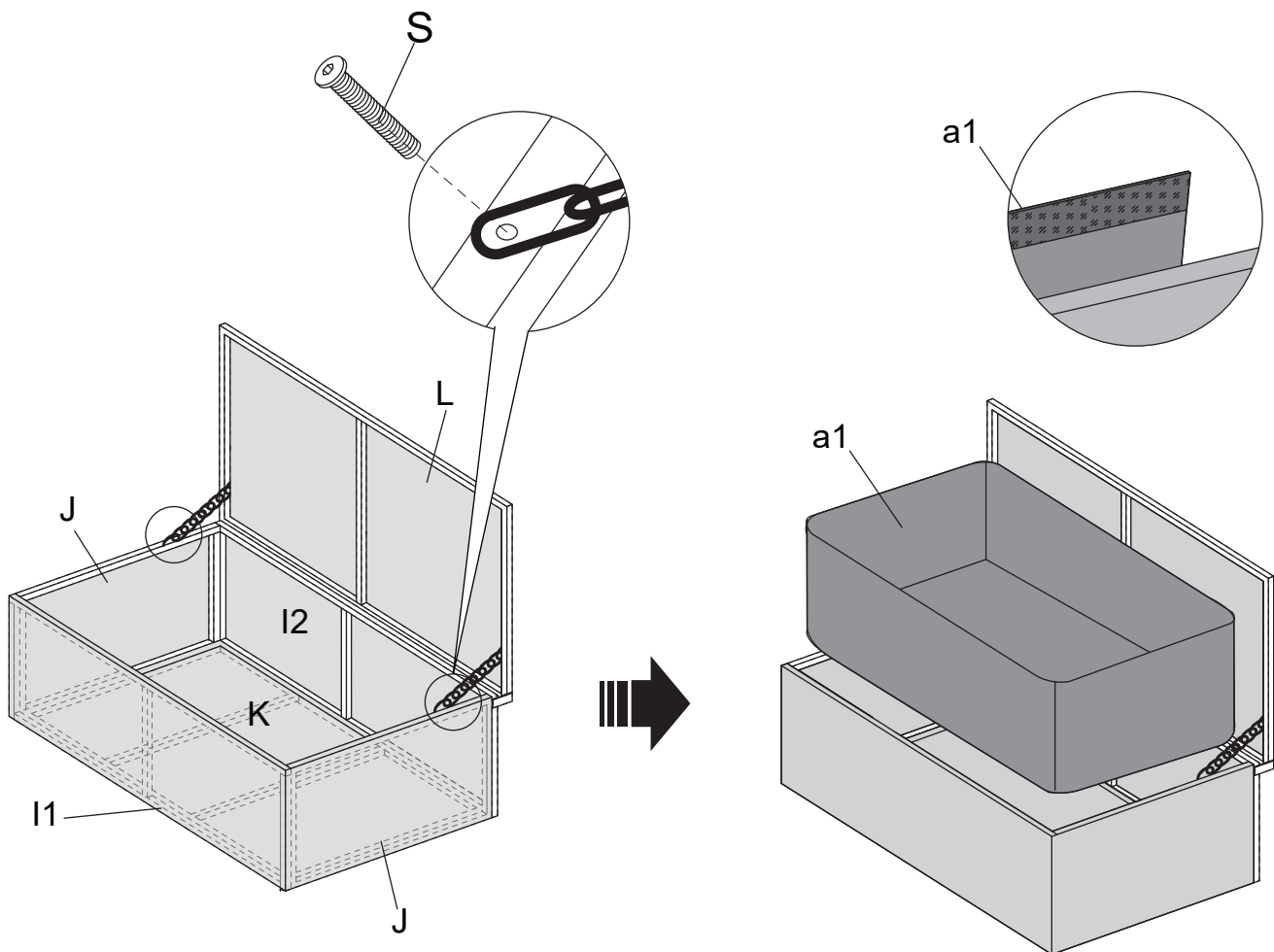

STEP 3

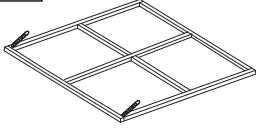
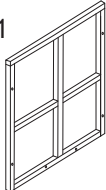
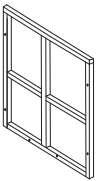
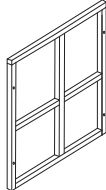
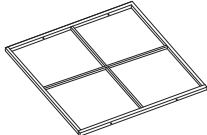
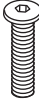

Side Table

Parts List (Side Table Needed)

M X1  Storage Top Panel	N1 X1  Storage Panel	N2 X1  Storage Panel	O X2  Storage Panel	P X1  Storage Bottom Panel
R1 X16  M6*30 Screw	S X4  M6*20 Screw	X X2  Washer	W X18  Washer	a2 X1  Storage Interior Cover

STEP 1

Please note : All panels with velcro face up.

