

















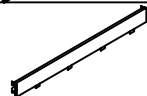



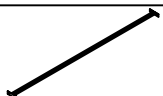

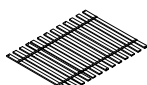

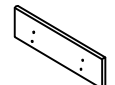

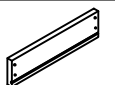
0013F

TOOLS REQUIRED				HARDWARE LIST			
PARTS LIST:							
NO	Description	Sketch	Quantity	NO	Sketch	Description	Quantity
1		Left Arm	1PC	A		Allen wrench M5	1PC
2		Right Arm	1PC	B		Bolt Ø5/16" x 1"	12PCS
3		Leg	4PCS	C		Bolt Ø5/16" x 2-1/2"	4PCS
4		Back Rail	1PC	D		Lock Washer $\frac{5}{16}$ "	16PCS
5		Front Rail	1PC	E		Flat Washer $\frac{5}{16}$ " x 21mm	16PCS
6		Back Rest	1PC	F		Allen wrench M4	1PC
7		Centre Rail	1PC	H		Bolt Ø1/4" x 5/8"	16PCS
8		Slats (13pcs)	1Set	I		Bolt Ø1/4" x 1-1/8"	14PCS
10		Drawer top panel	2PCS	J		Lock Washer 1/4"	30PCS
11		Drawer Side panel	4PCS	K		Flat Washer 1/4" x 16mm	30PCS
12		Drawer Back panel	2PCS	L		Dowel Ø8X30mm	16PCS
13		Drawer front panel	2PCS	M		Cam Bolt	24PCS
14		Drawer Bottom panel	2PCS	N		Cam Lock	24PCS
15		Drawer Bottom Centre Panel	2PCS	0013F			
16		Drawer Bottom Side Panel	4PCS				
17		Wheel	8PCS				

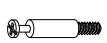
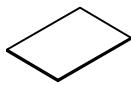
0013F

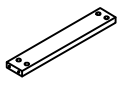
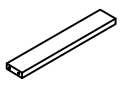

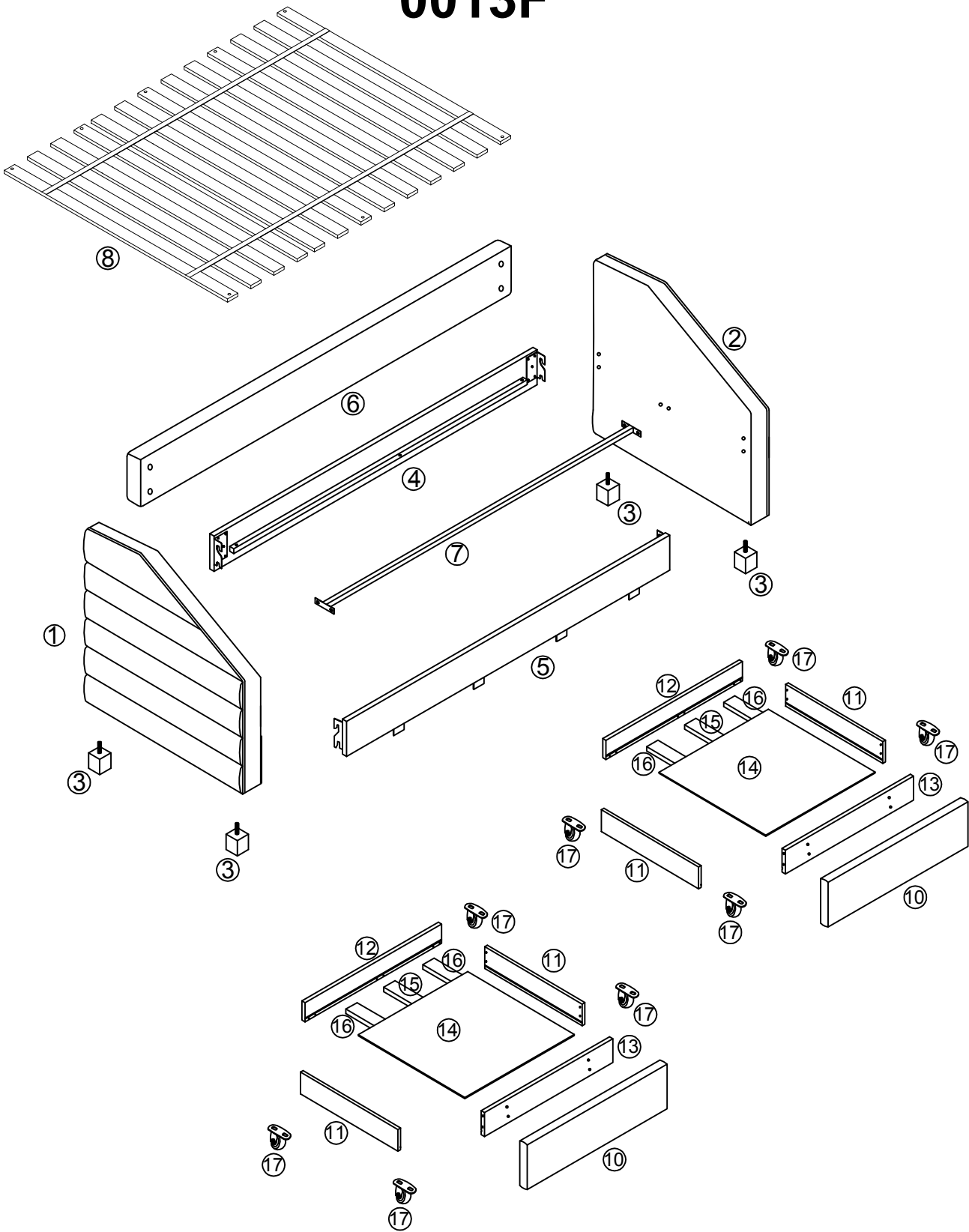
STEP 1

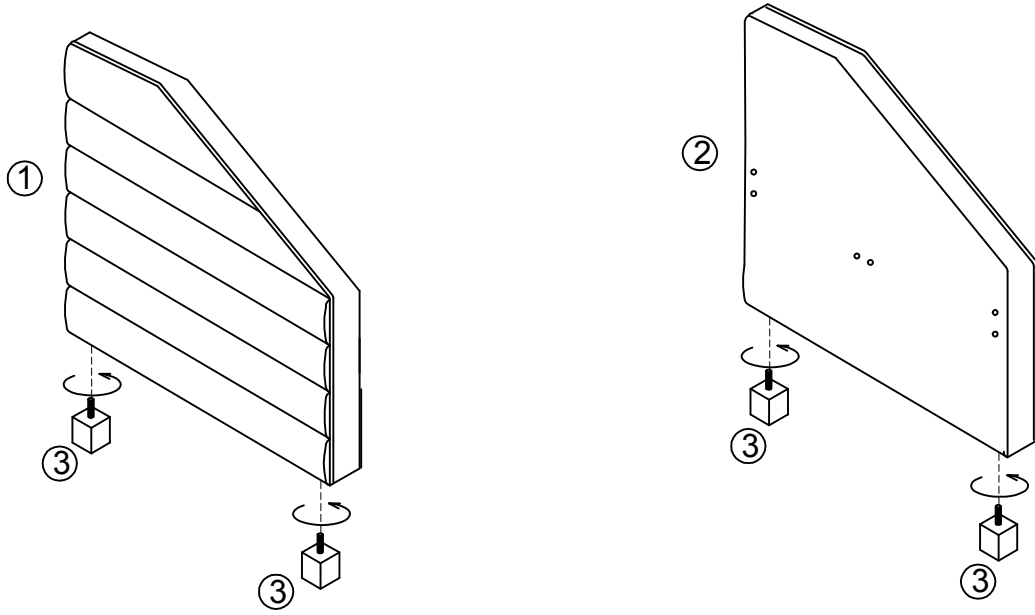

STEP 2

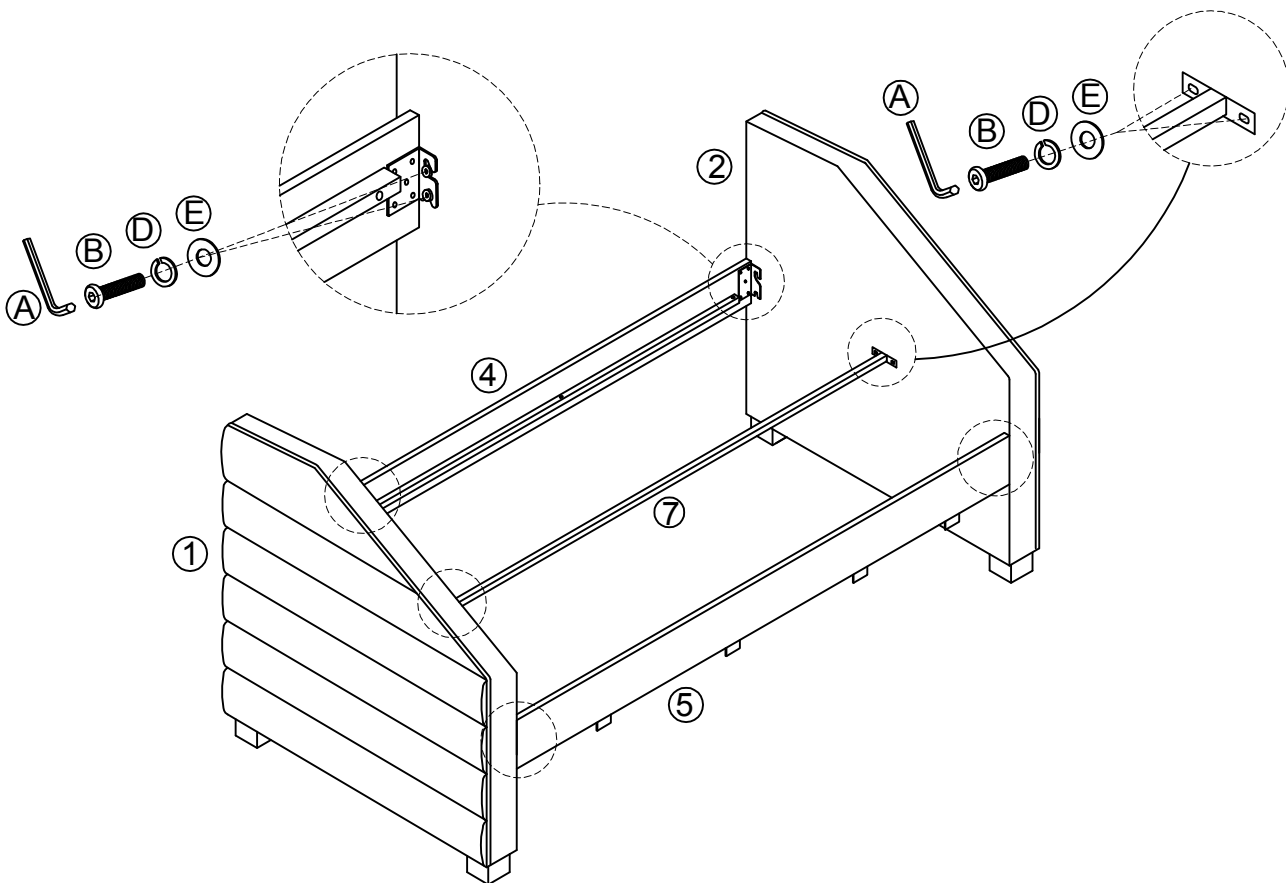

STEP 3

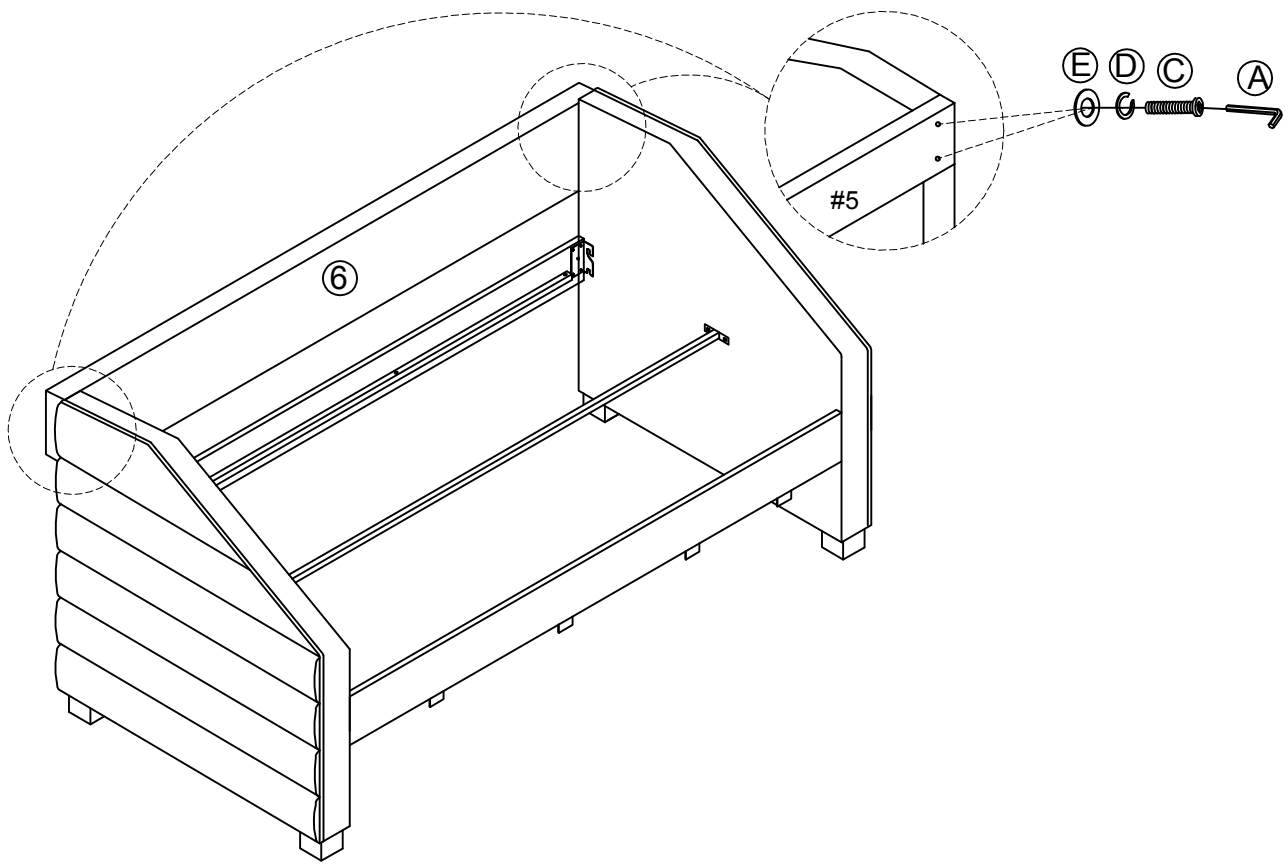

STEP 4

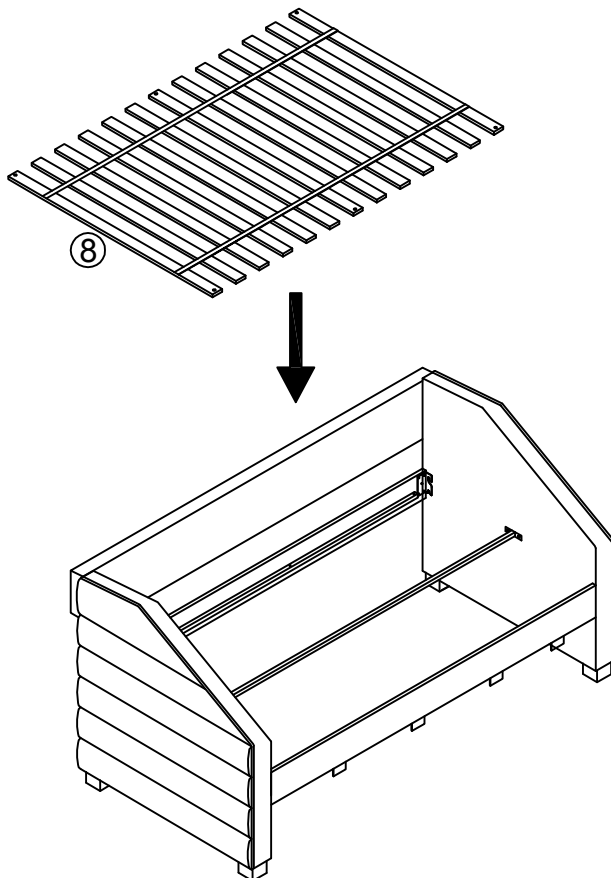

STEP 5

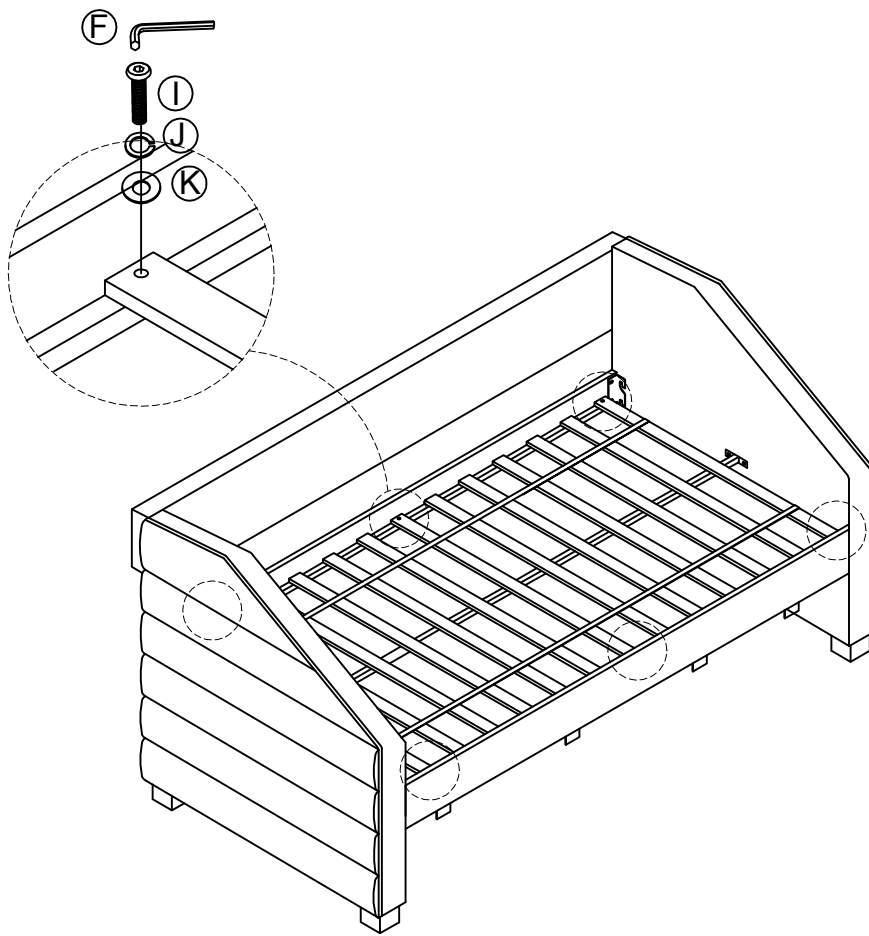

STEP 6

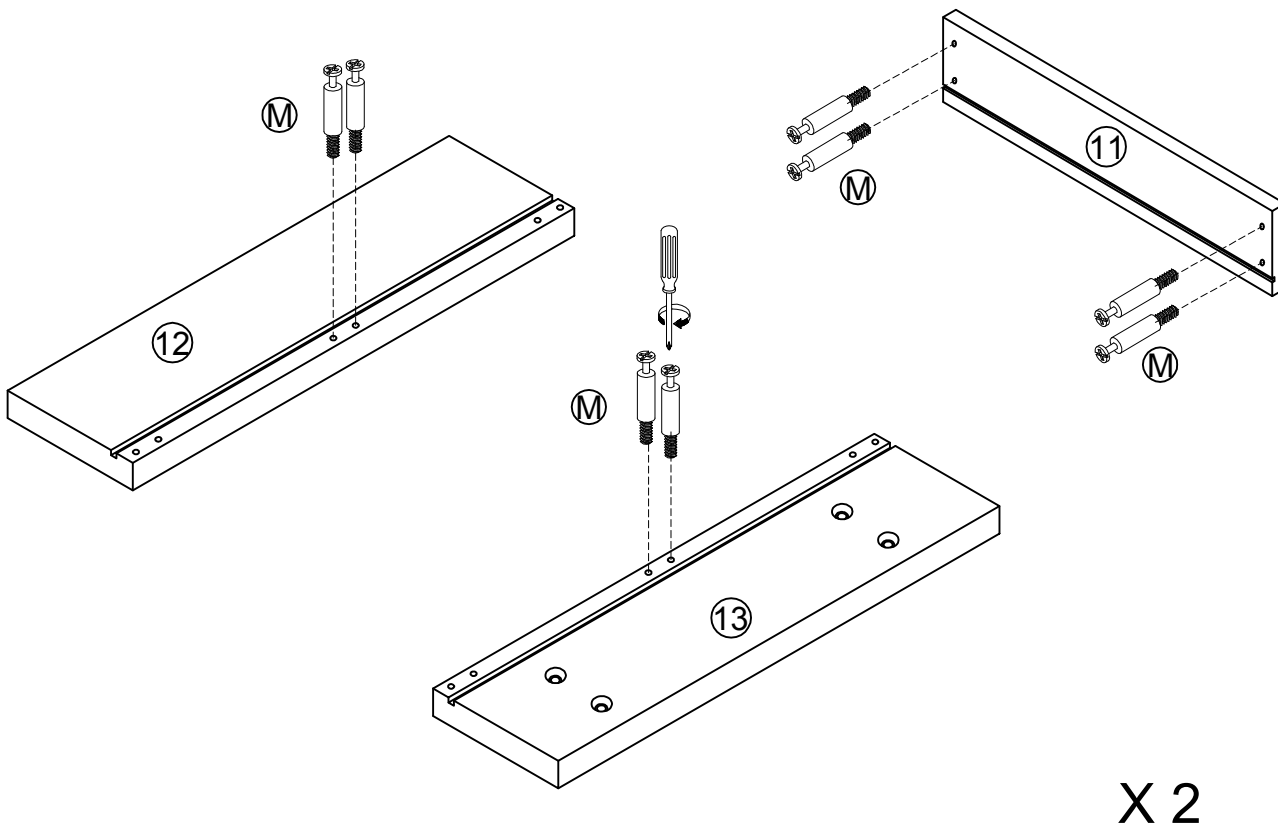

STEP 7

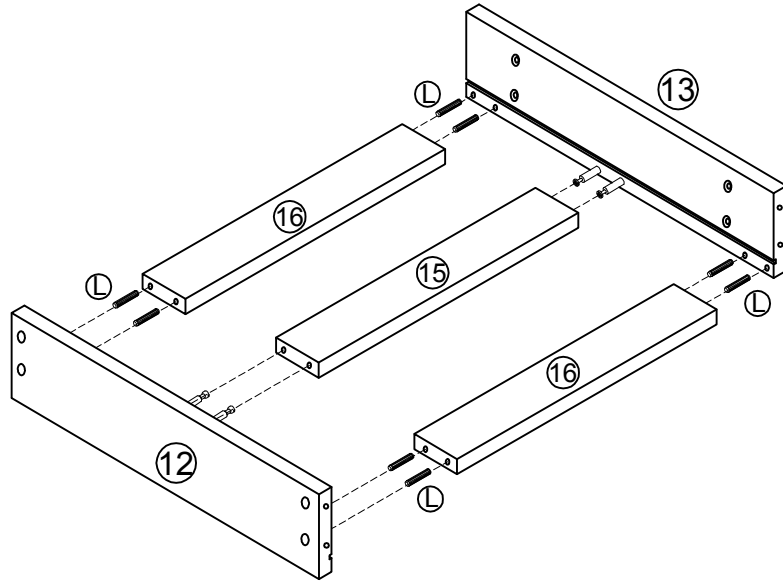

X 2

STEP 8

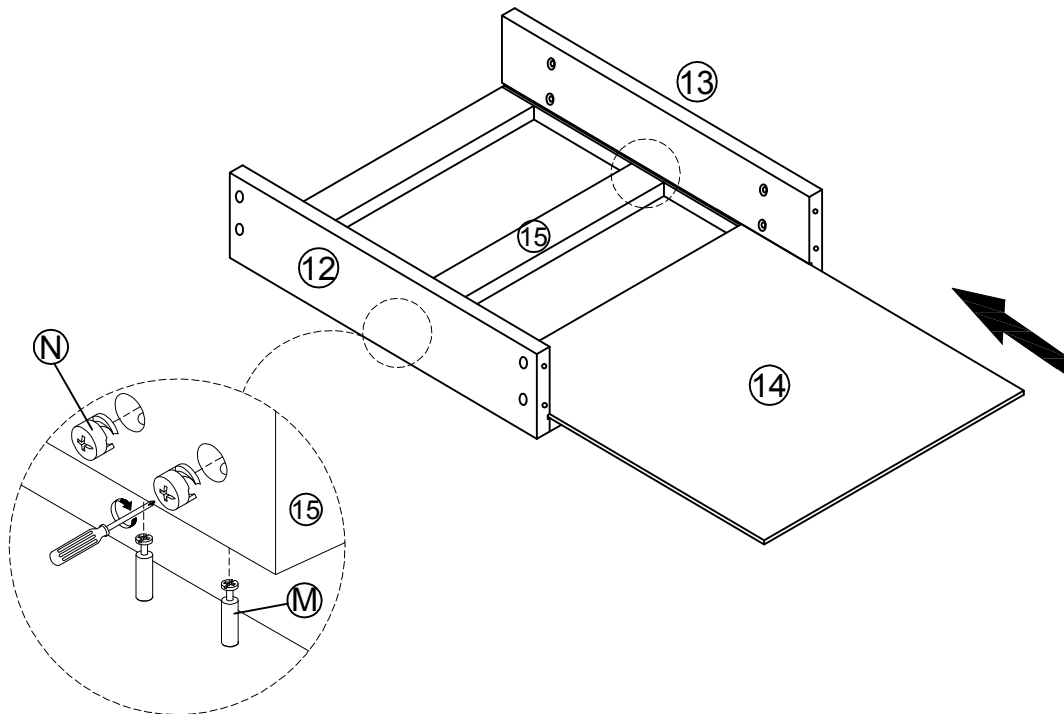

X 2

STEP 9

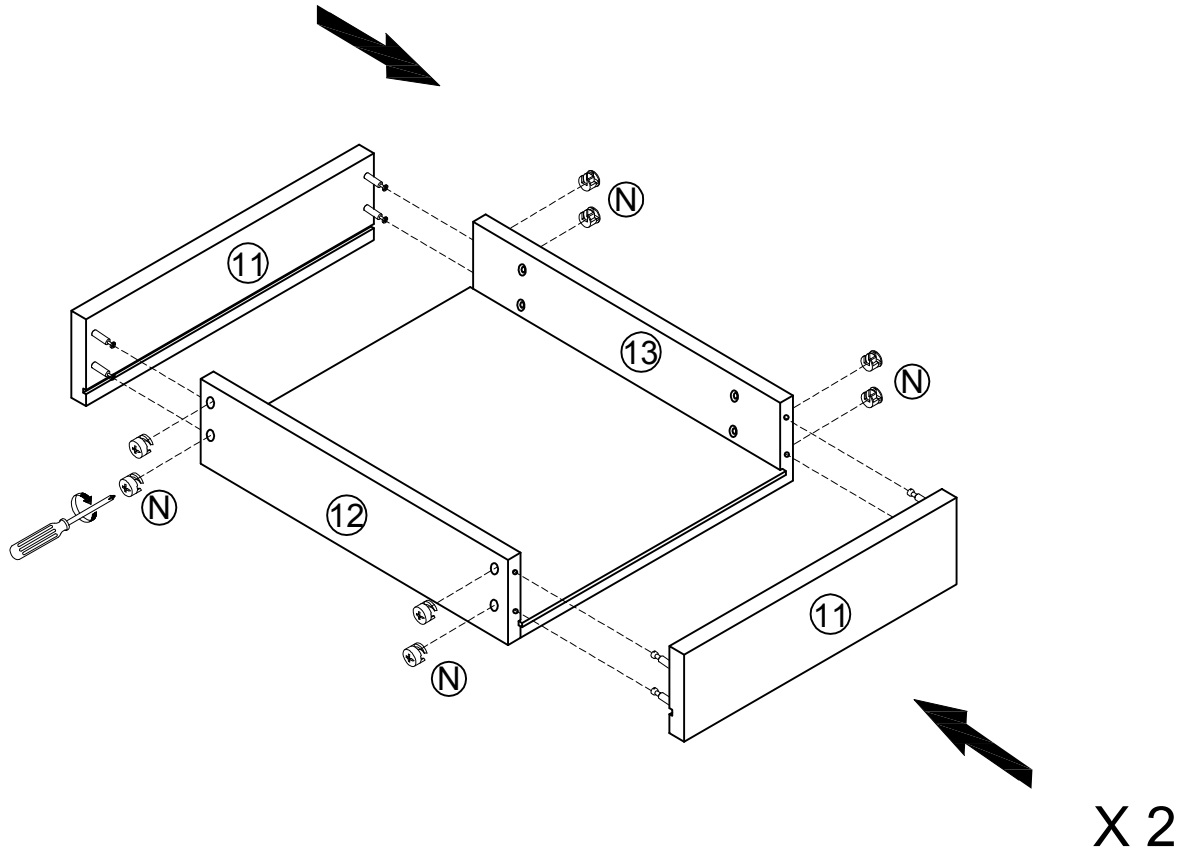

STEP 10

