

# Installation & Assembly

Version: 1.0

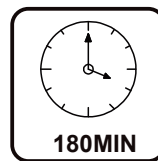
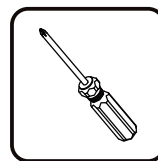
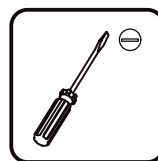
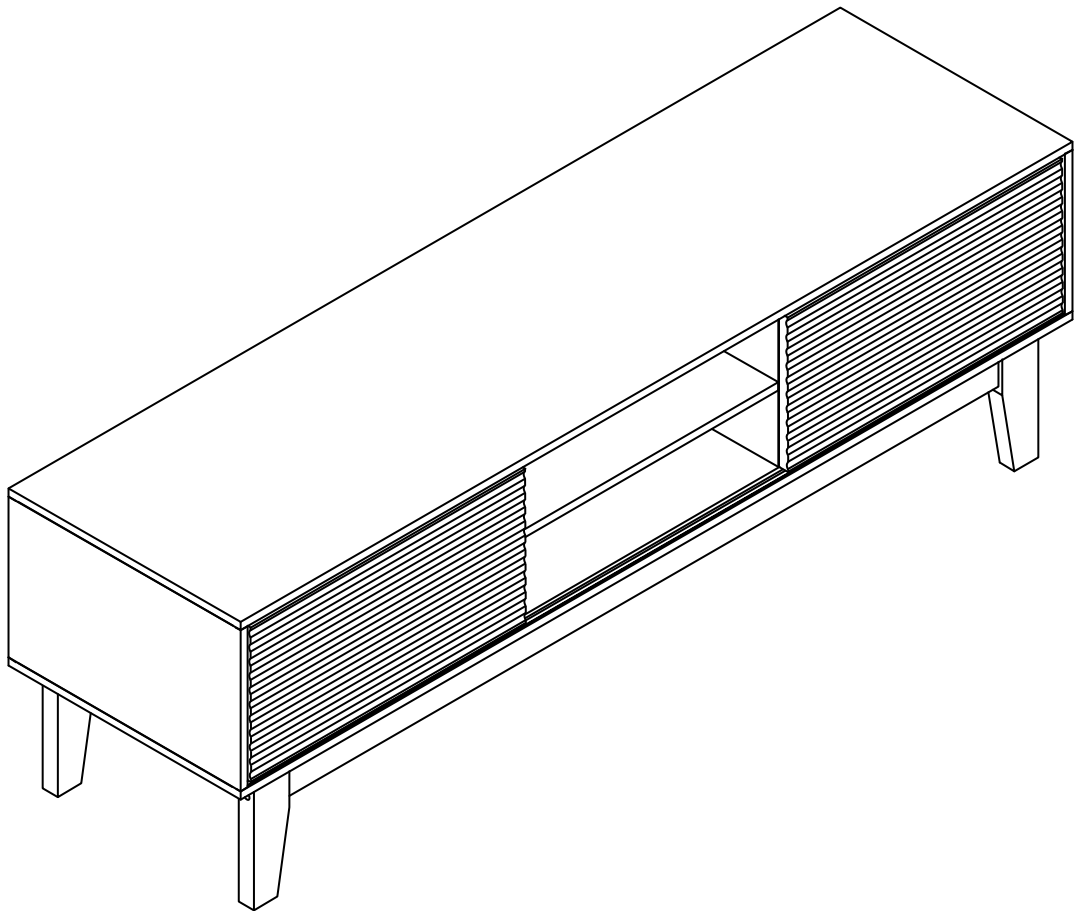

**EN\_IMPORTANT, RETAIN FOR FUTURE REFERENCE: READ CAREFULLY.**

## USING CAM LOCK AND QUICKFIT

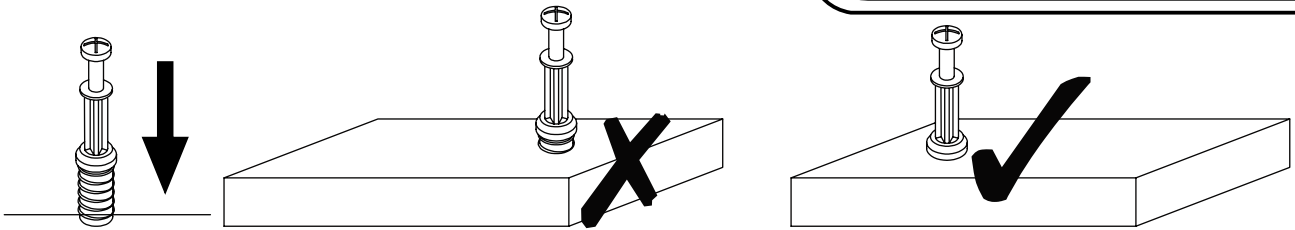

**EN\_QUICKFIT:** Tighten quickfit until shoulder is flush with panel. Do not overtighten or undertighten.

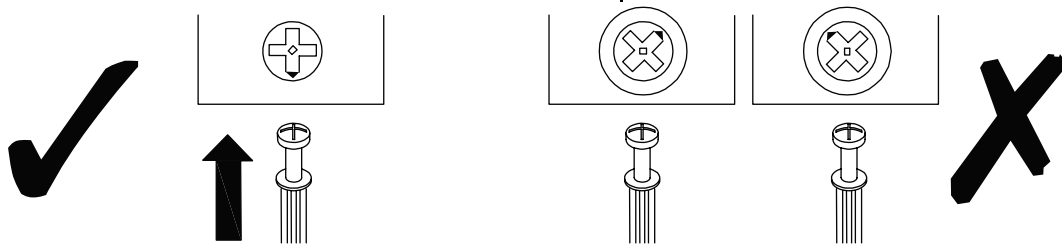

**EN\_CAM LOCK:** When fitting cam lock, ensure starting position is correct before you insert connecting quickfit.

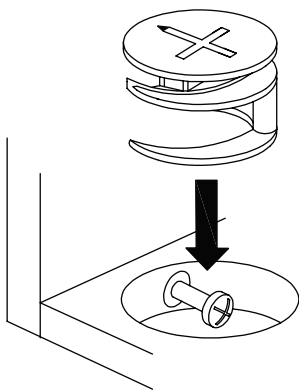



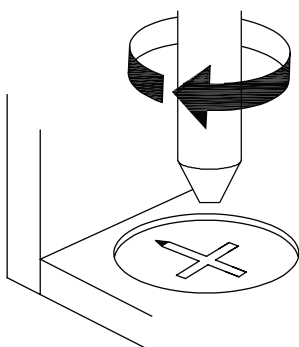



**EN\_Quickfit head** should be in the centre of the cam lock when the two panels are joined.  
Cam lock should be inserted before quickfit.

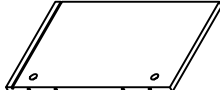
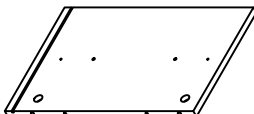
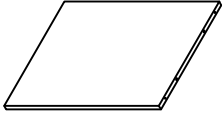
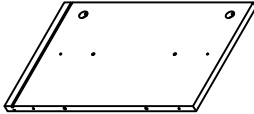
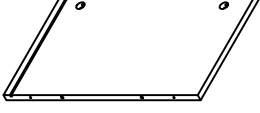
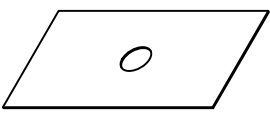
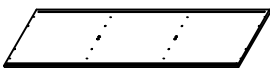

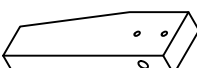
**EN\_Turn** cam lock clockwise to tighten.

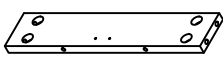
**PACKING DELALS**

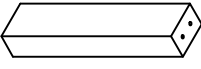
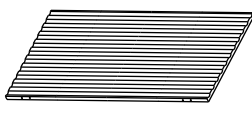
NO.	PARTS	QTY	SPARE
①		x1	
②		x1	
③		x1	
④		x1	
⑤		x1	
⑥		x1	
⑦		x3	
⑧		x1	
⑨		x2	
⑩		x2	

NO.	PARTS	QTY	SPARE
⑪		x2	
⑫		x2	
⑬		x2	
⑭		x2	
	 Hardware Kit	x1	

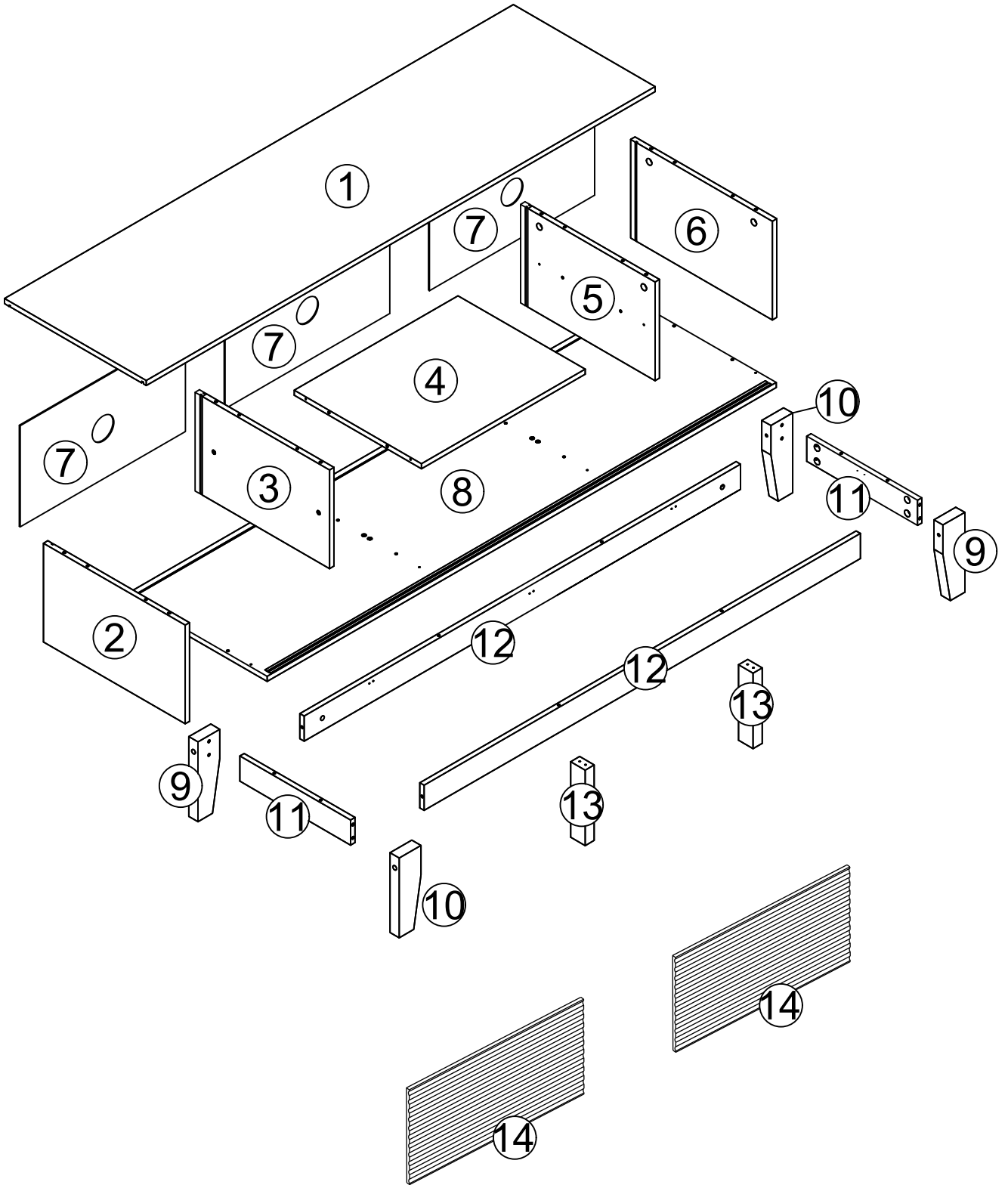

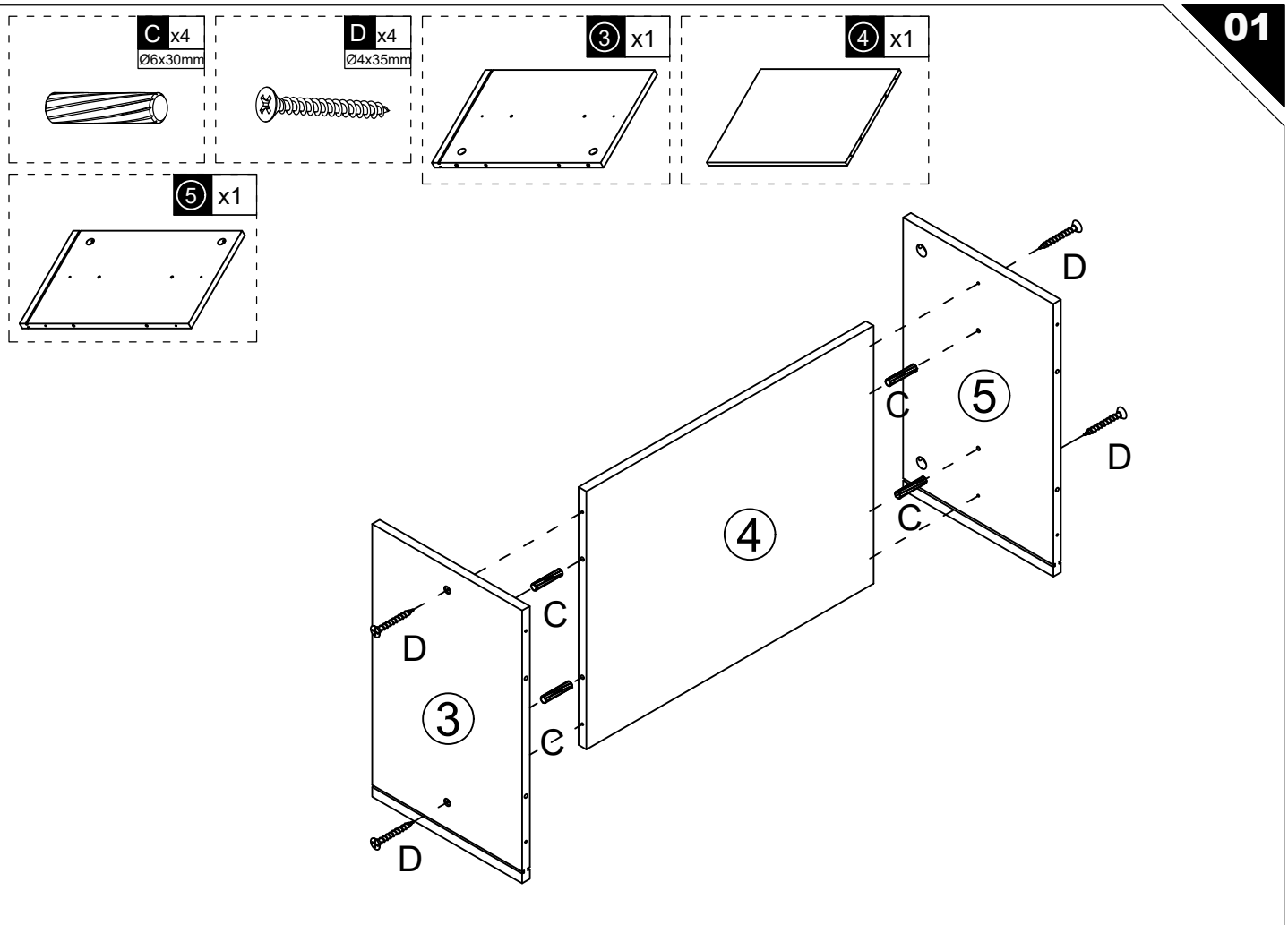
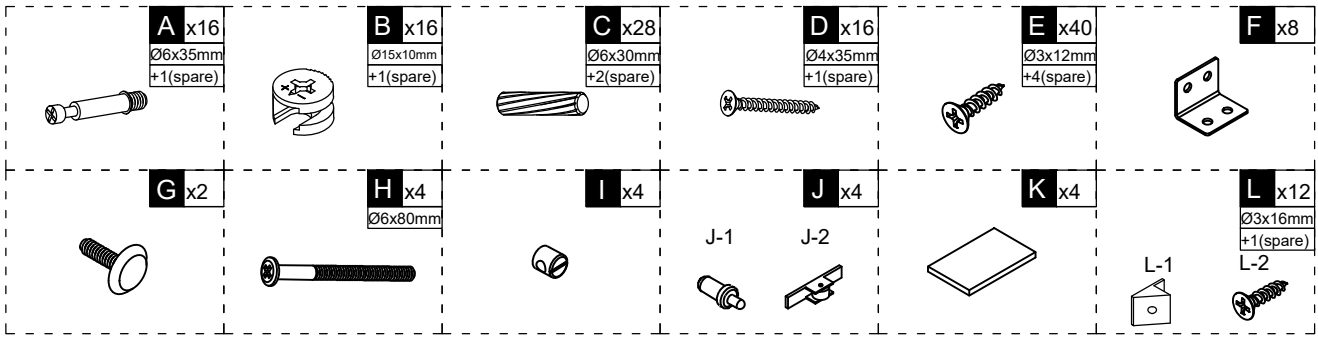

A x8  
Ø6x35mm

1 x1

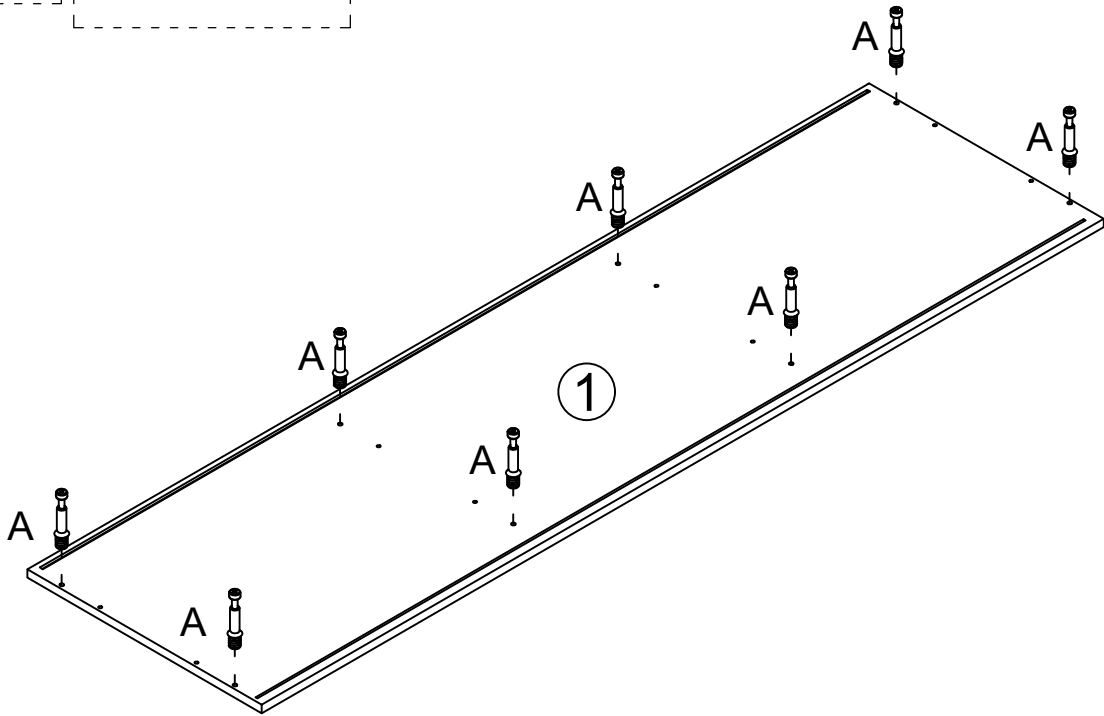
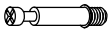

B x8  
Ø15x10mm

C x8  
Ø6x30mm

2 x1

6 x1

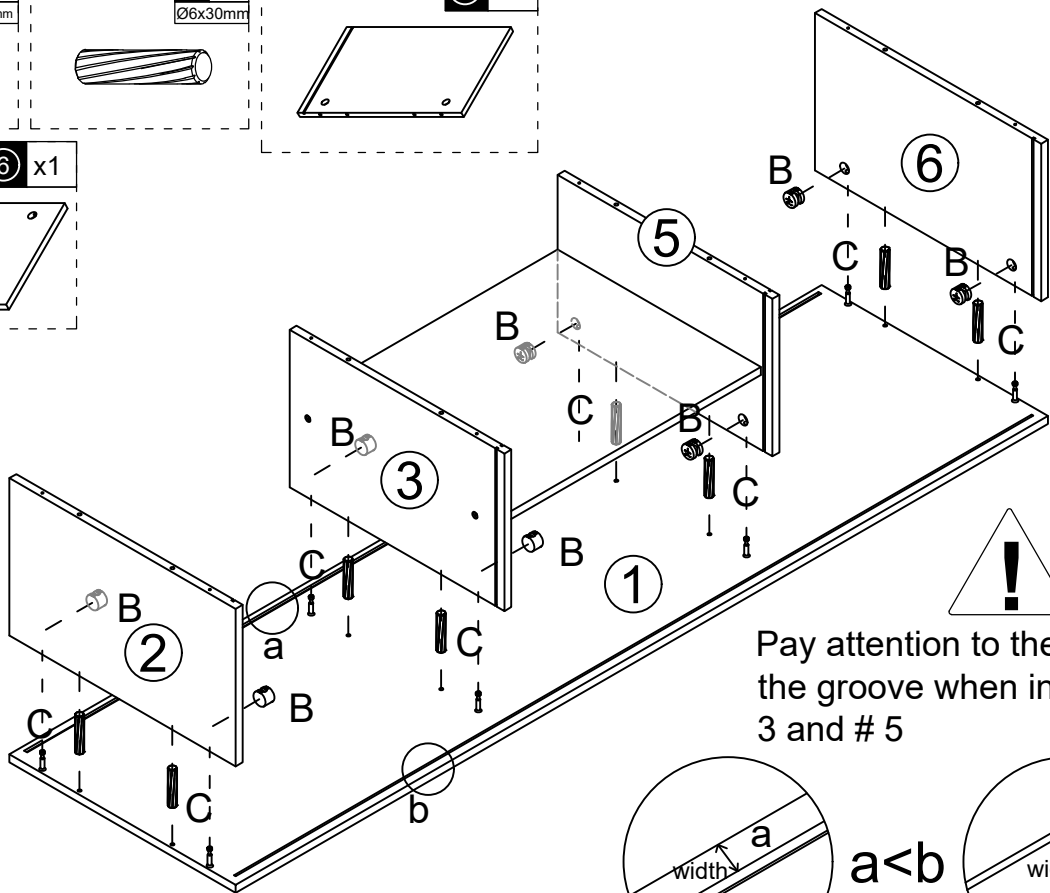
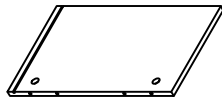

Pay attention to the width of the groove when installing # 3 and # 5

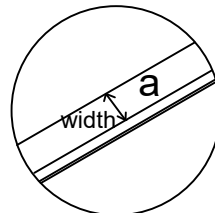

$a < b$

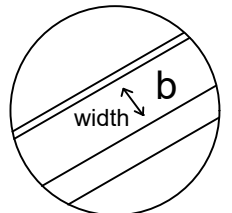

7 x3

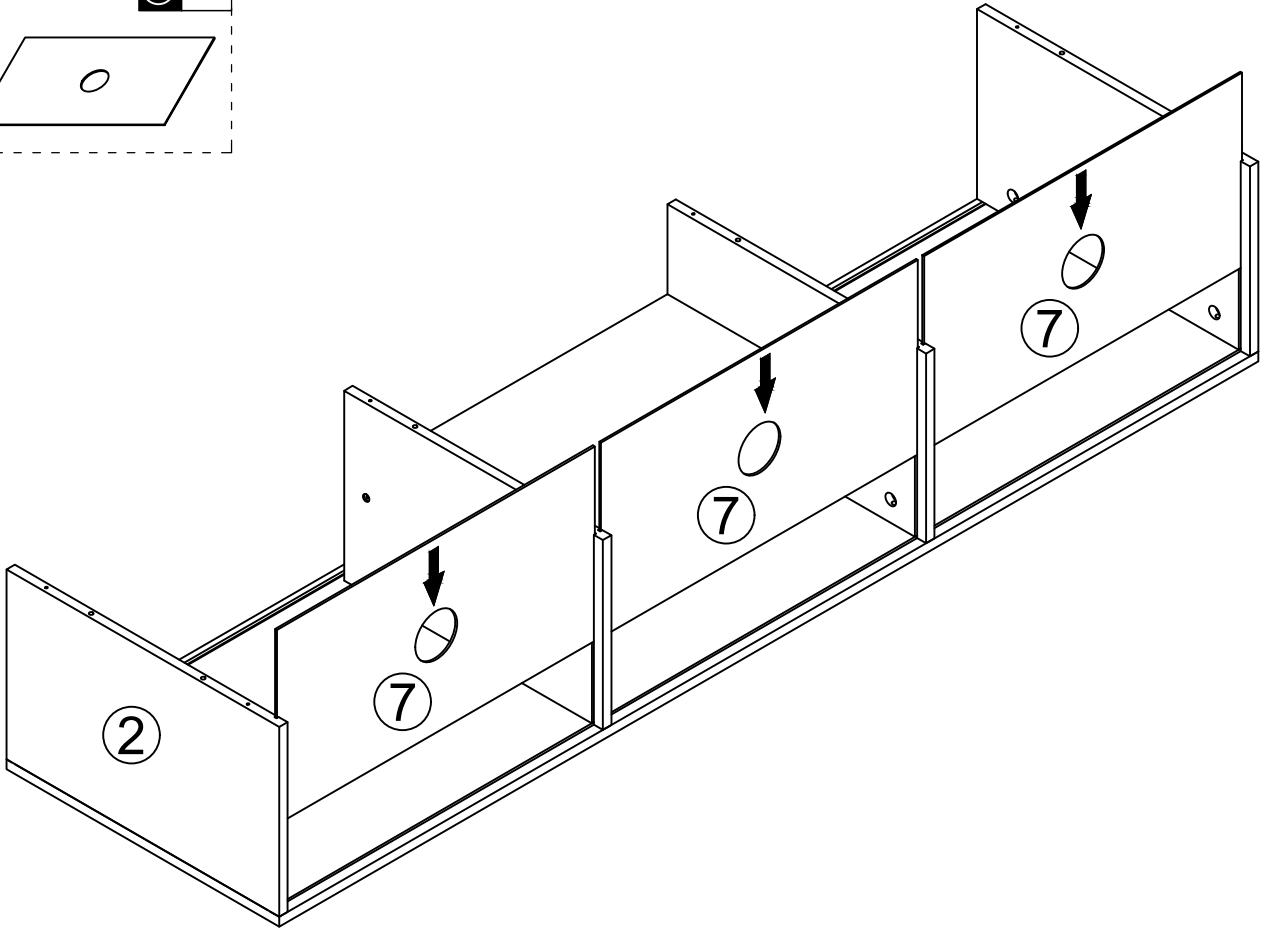

D x4  
Ø4x35mm



G x2



8 x1

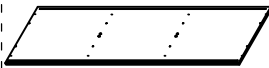

13 x2

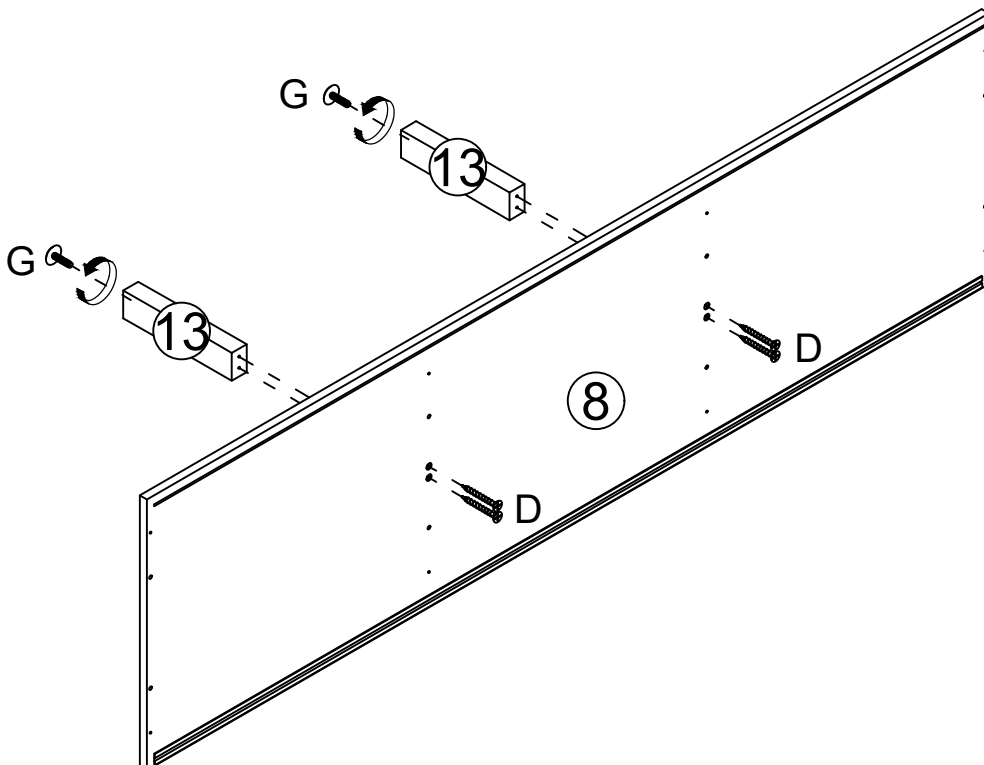
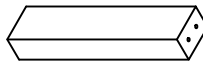

C x8  
Ø6x30mm

D x8  
Ø4x35mm

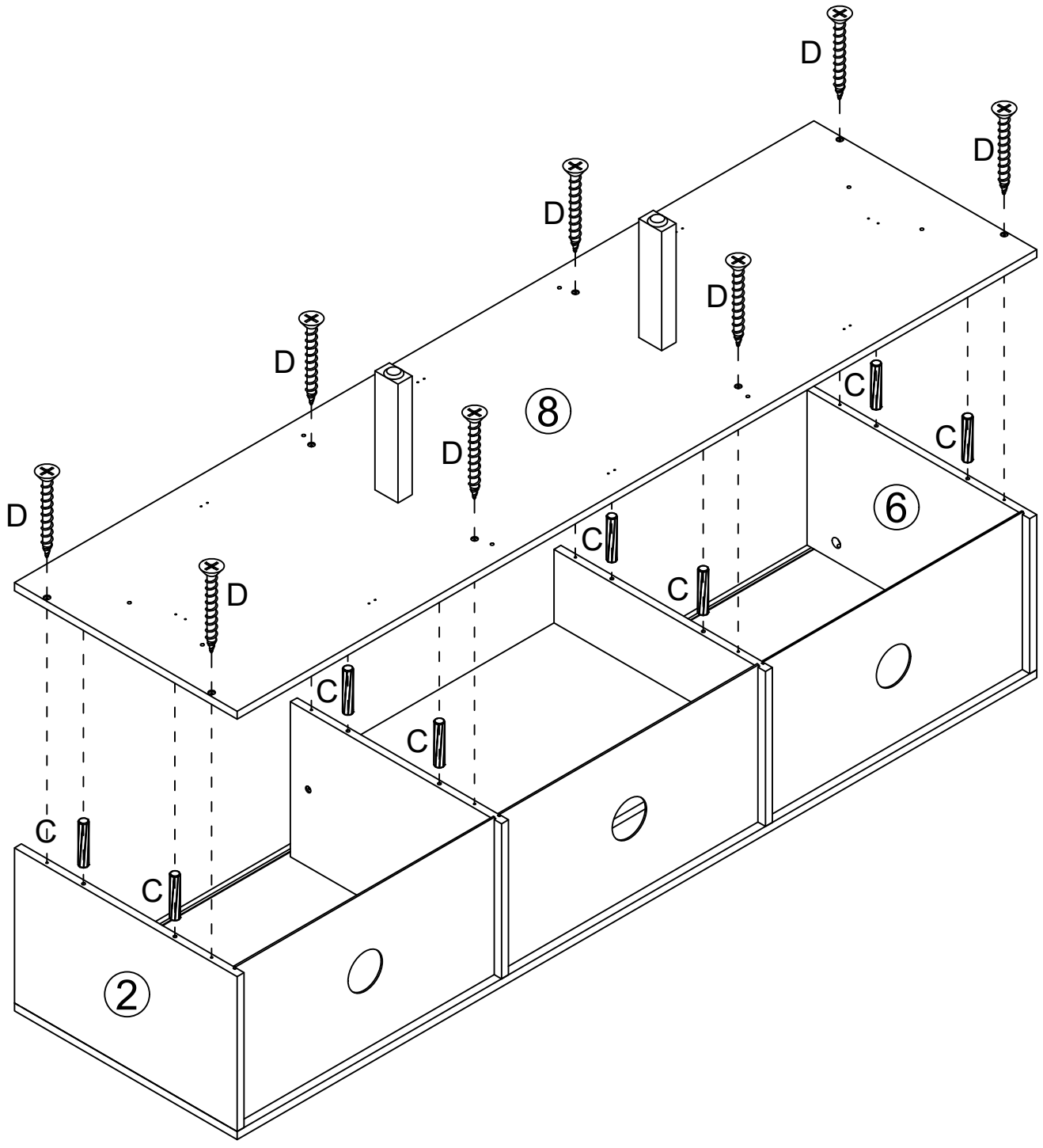

A x8  
∅6x35mm

B x8  
∅15x10mm

E x4  
∅3x12mm

F x2

11 x2

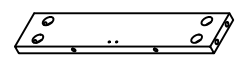
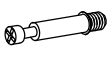

9 x2

10 x2

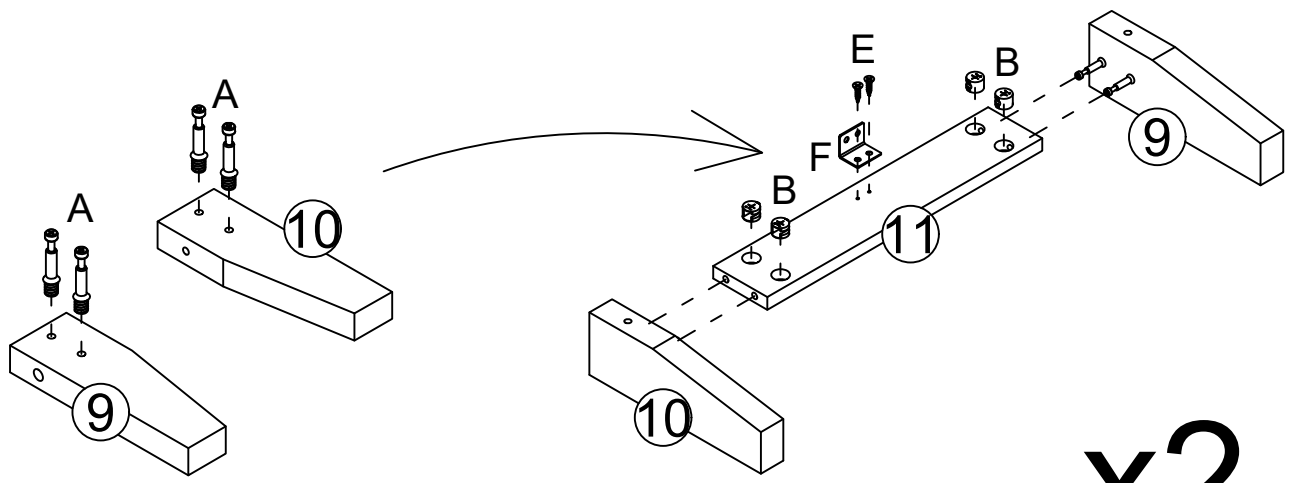
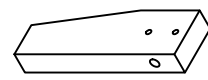
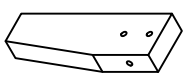

x2

E x12  
∅3x12mm

F x6

12 x2

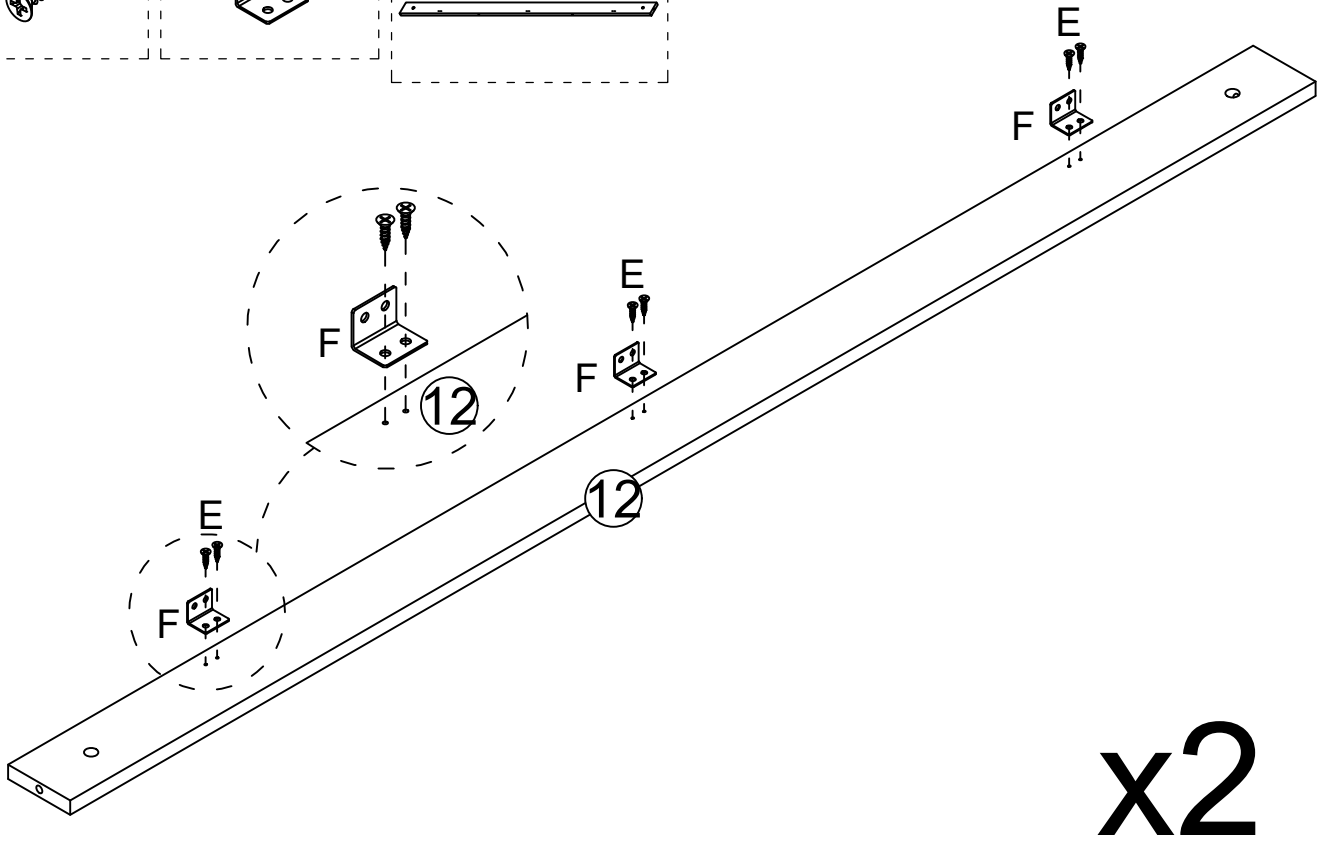

x2

H x4  
Ø6x80mm

I x4

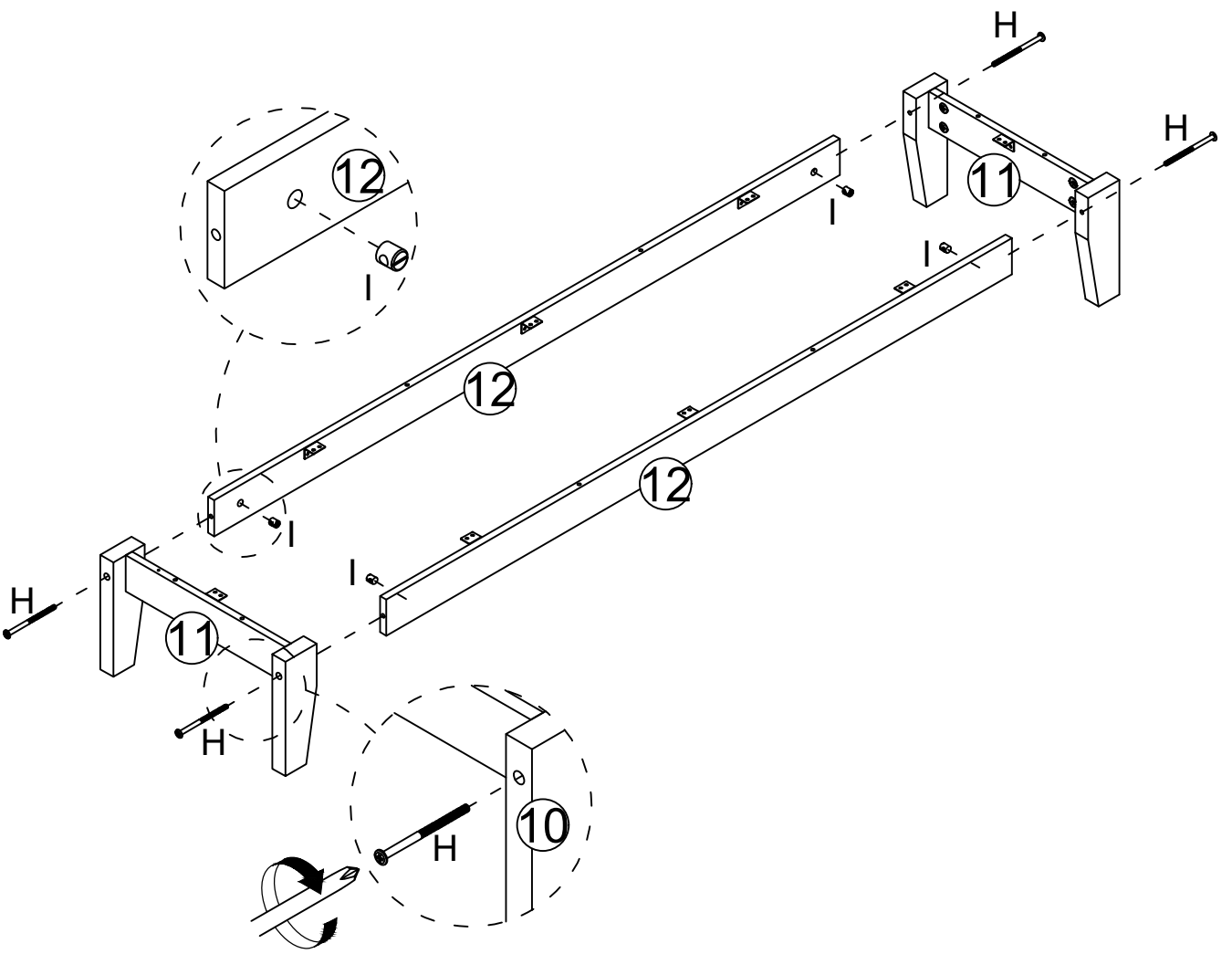

C x8  
Ø6x30mm

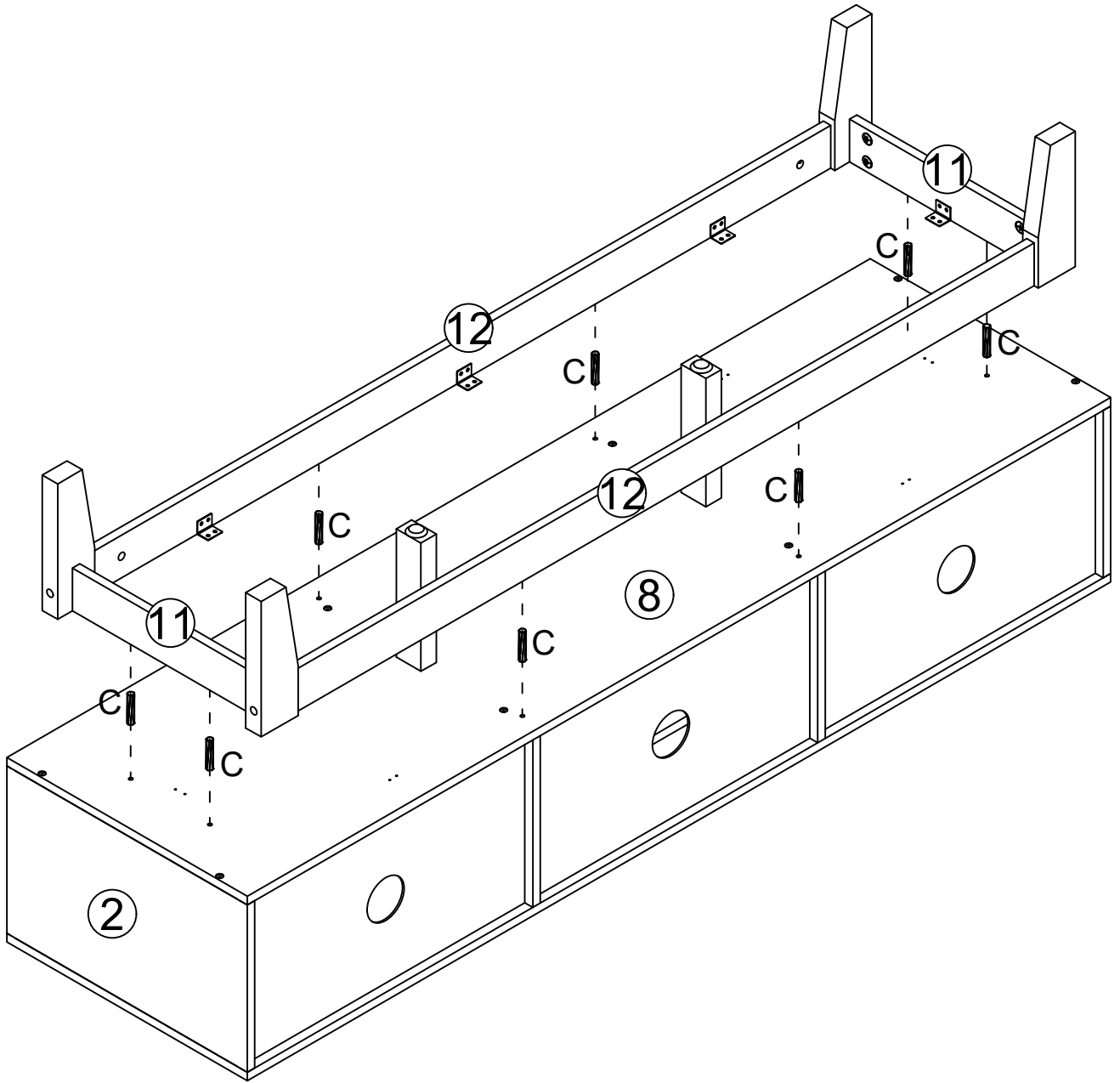
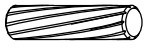

E x16  
Ø3x12mm

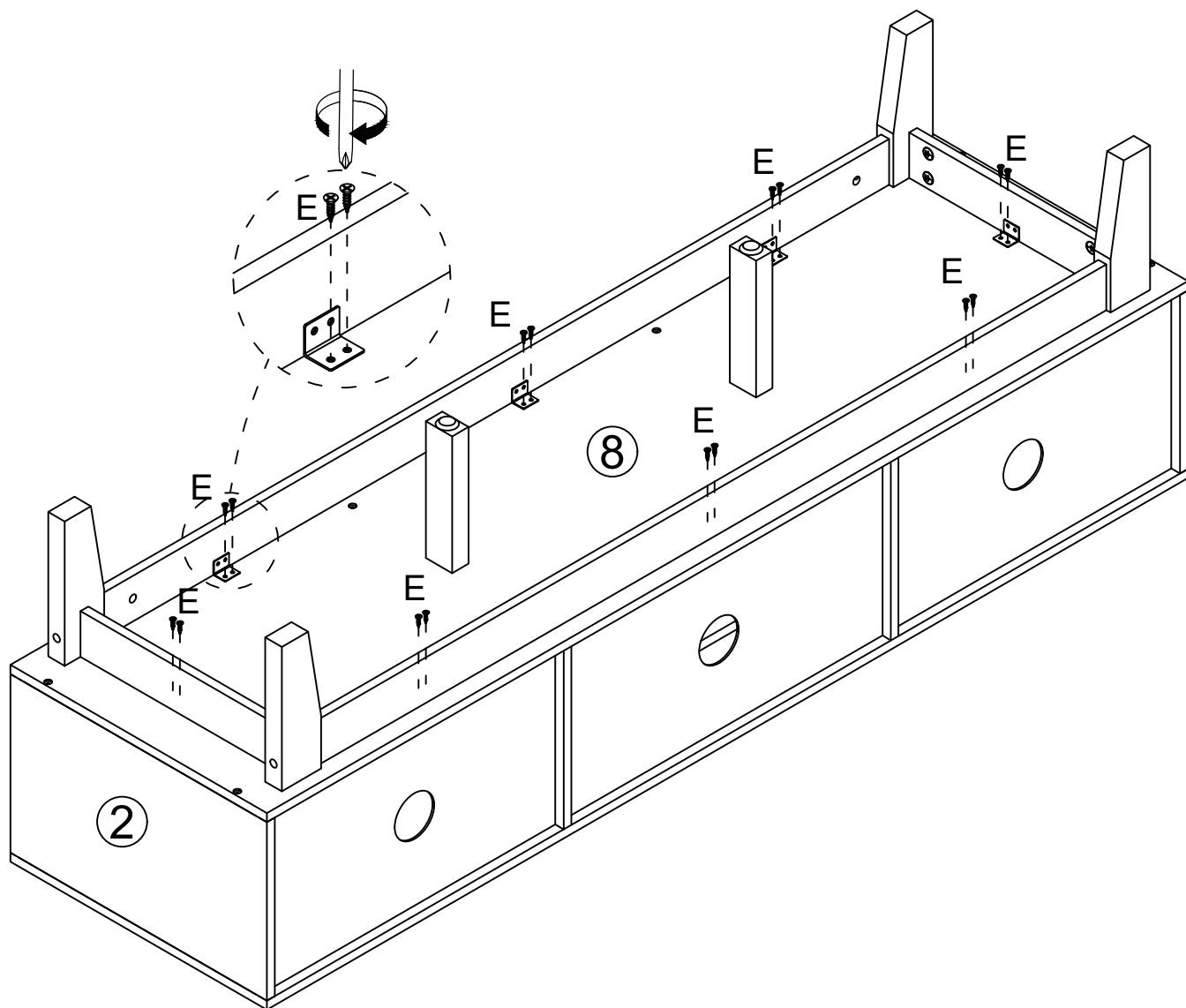

L x12  
Ø3x16mm

L-1

L-2

K x4

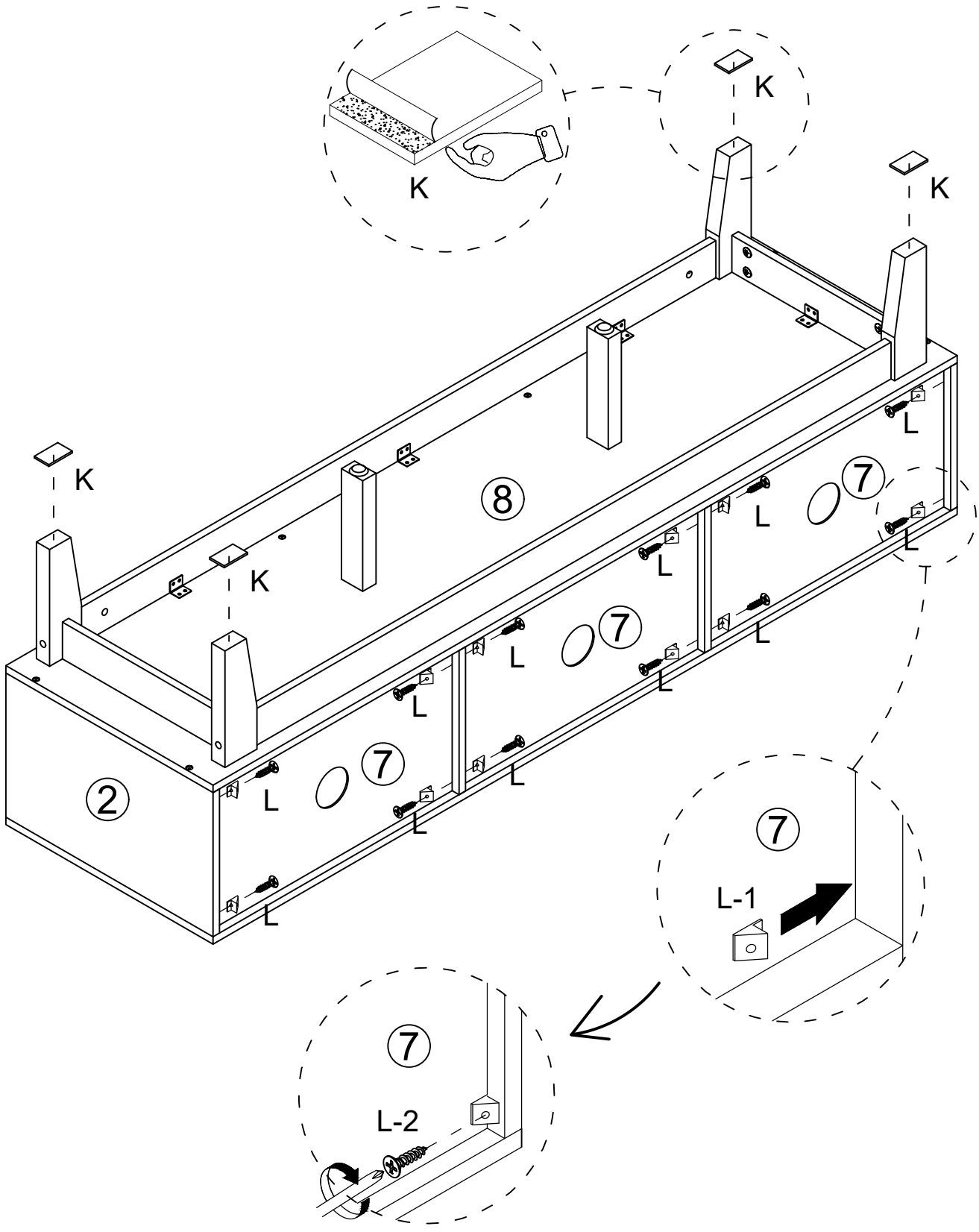

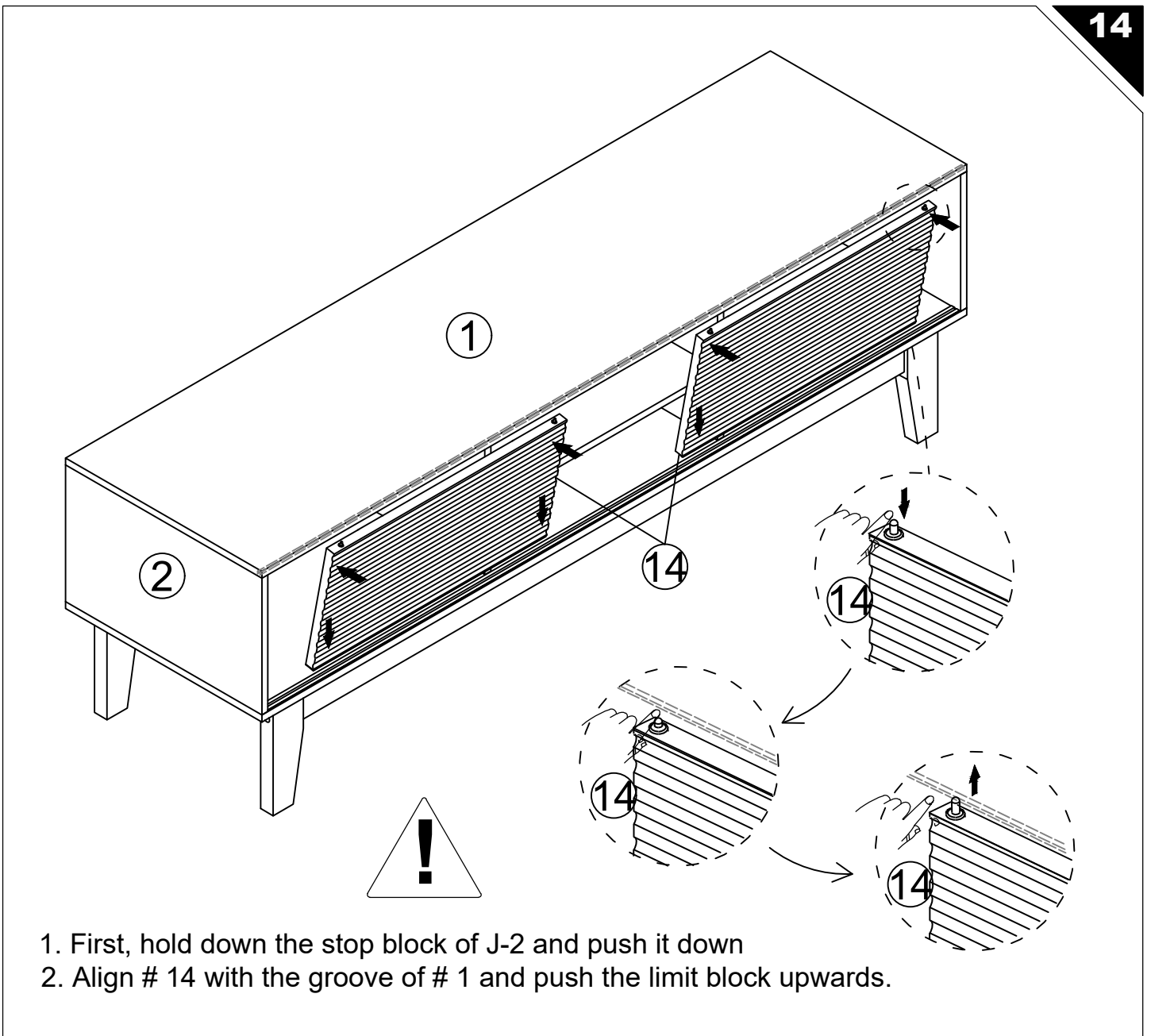
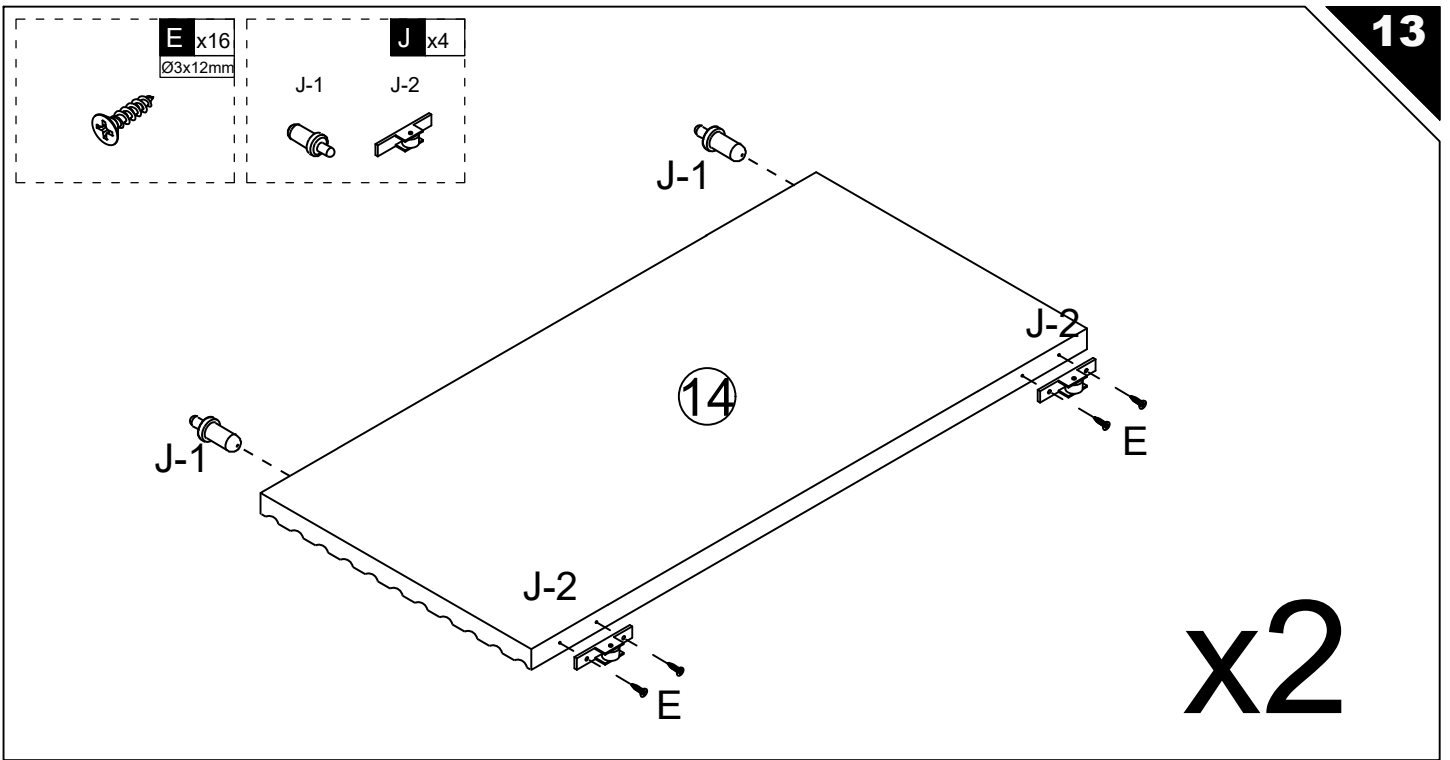

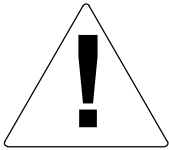
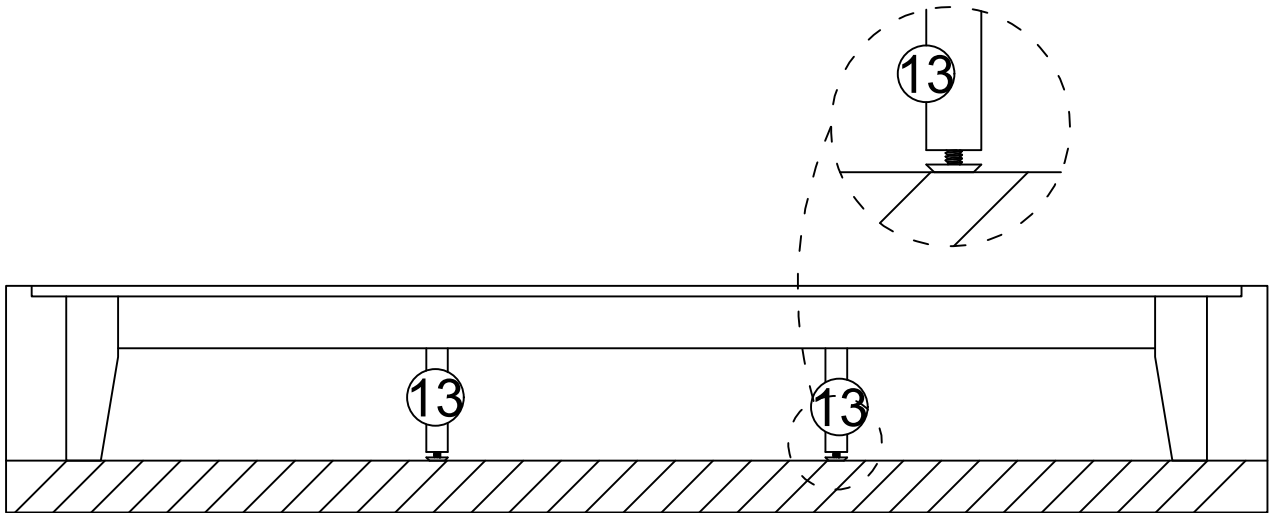

If the ground is uneven, we can rotate the adjusting foot of the # 13 board to keep it level with the ground

