

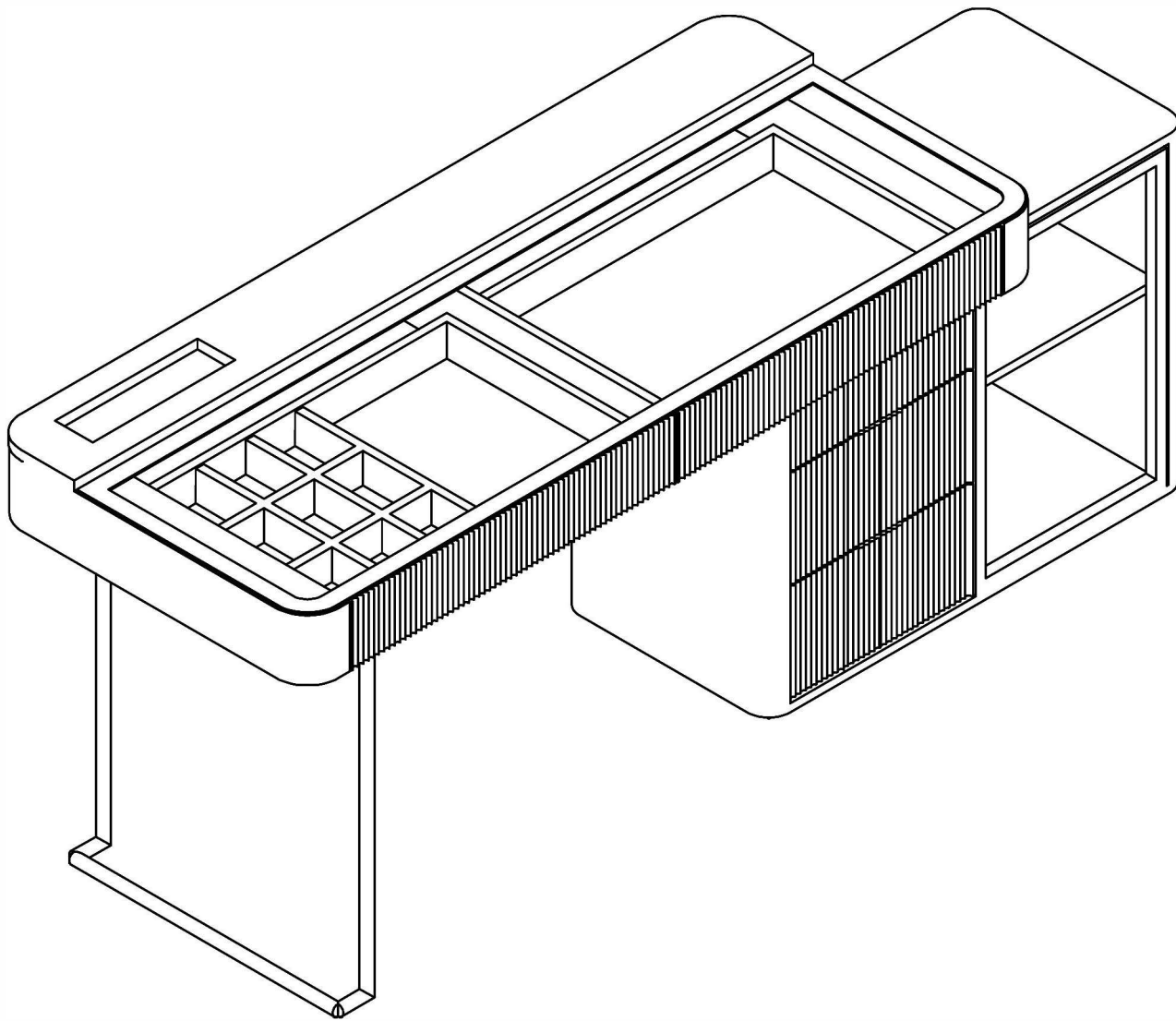







ASSEMBLY INSTRUCTION

P1



NO.	Parts	Quantity
A		Φ4x8=1
B		M6x35=6
C		Sensor light=2
D		Small round puller=1
E		Glass Gasket=6
F		Metal handle=3
G		Φ3x16=6

PRODUCT PARTS/QUANTITY

① Main cabinet x1

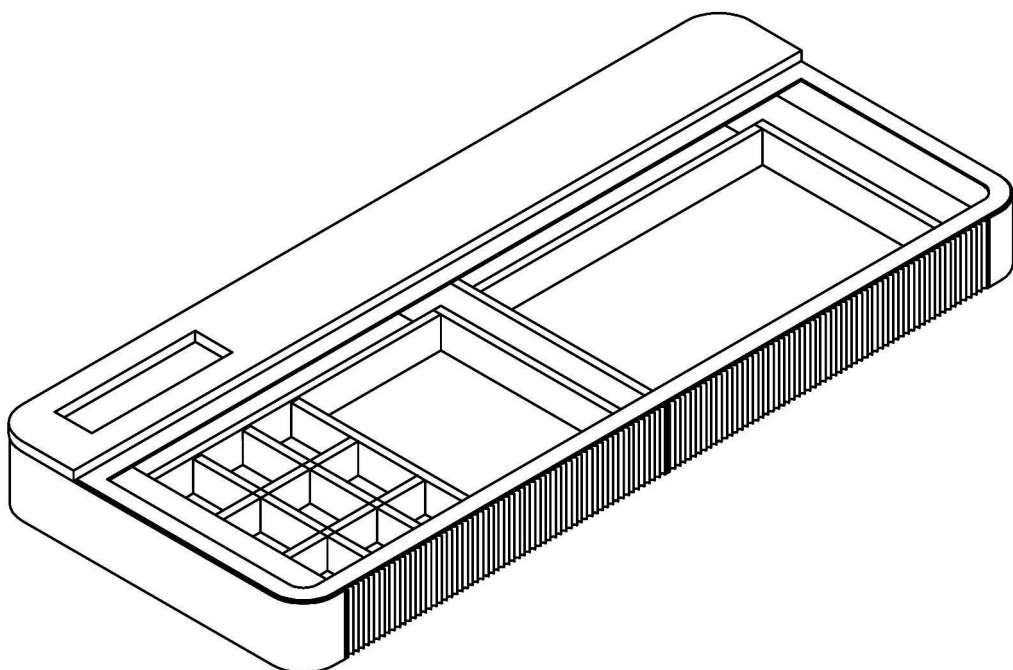

② Main Cabinet Hardware Legs x1

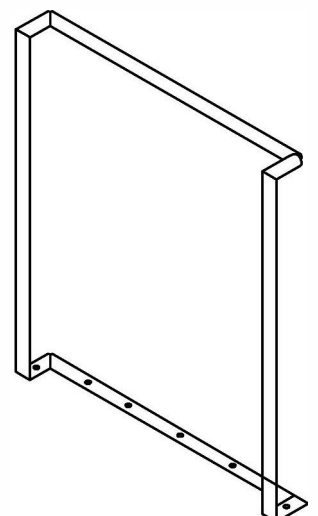

PRODUCT PARTS/QUANTITY

③ Secondary cabinet x1

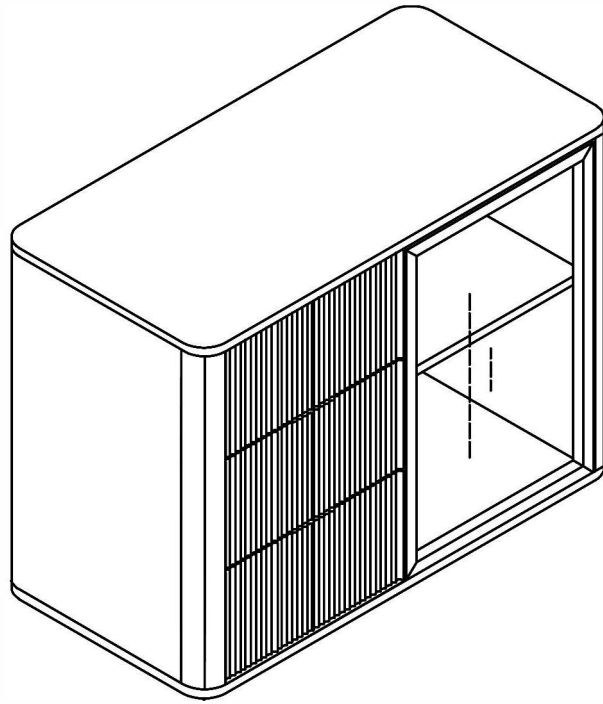

Main Cabinet Accessories

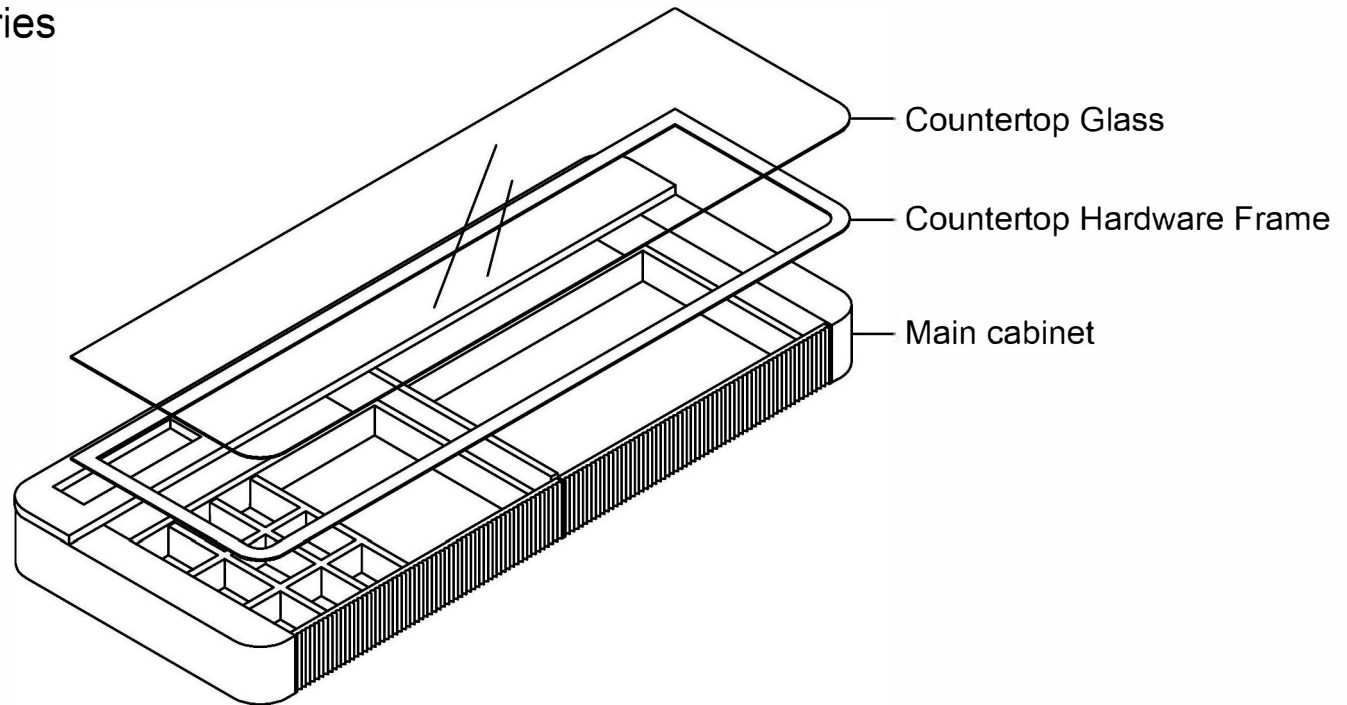

PRODUCT INSTALLATION STEPS SCHEMATIC

STEP 1 : MAIN CABINET MOUNTING SUPPORT FEET

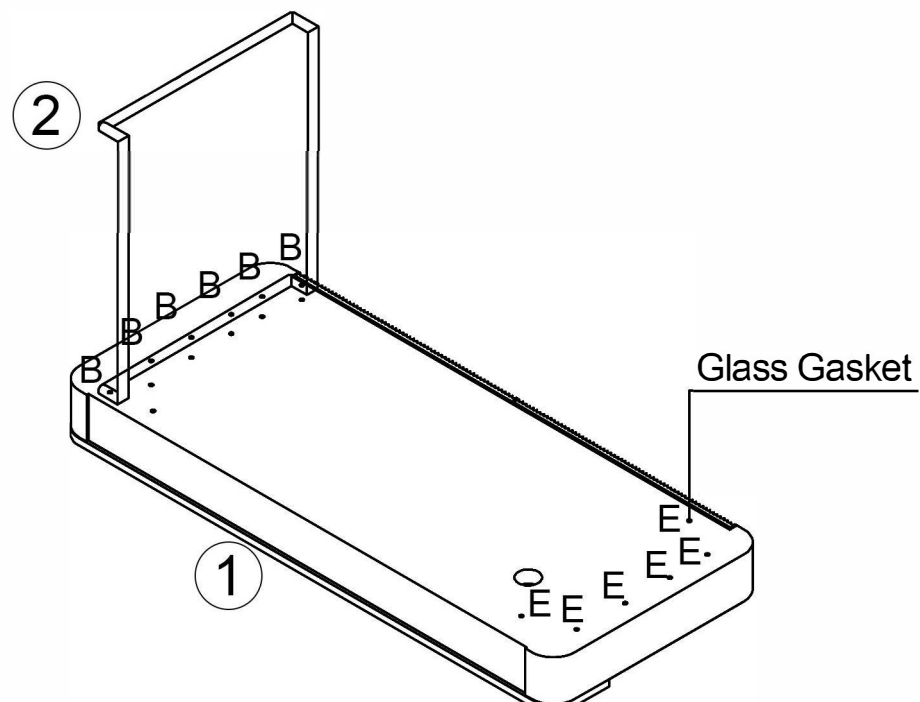

STEP 2 : SUB-CABINET MOUNTED PULLS

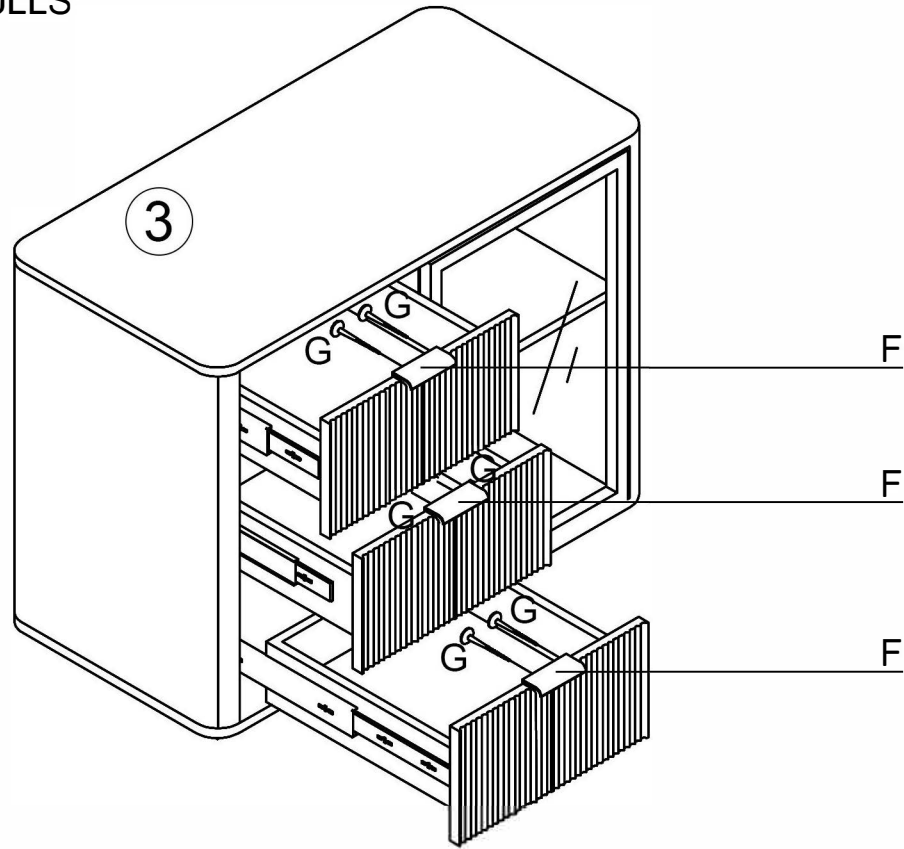

STEP 3 : PLACEMENT OF SENSOR LIGHTS

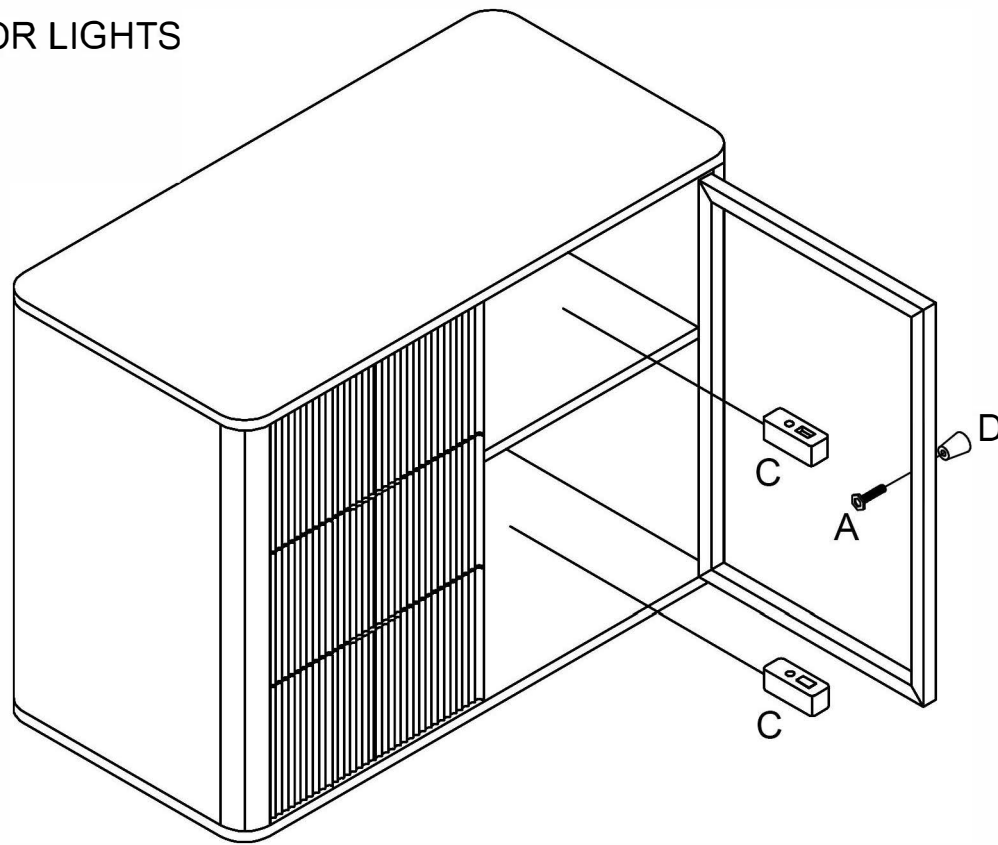

STEP 4 : INSTALLATION COMPLETED

