









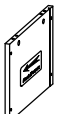

Thank you for purchasing this quality product. Be sure to check all packing materials carefully for small parts, which may have come loose inside the carton during shipment. Identify and count all items and compare with the PARTS LIST and/or HARDWARE LIST shown below.

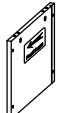

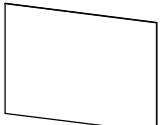
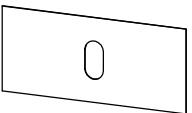
Please read the instructions thoroughly before assembly.

1. We recommend that you assemble this product with the assistance of another person; this will make the assembly easier, and will help eliminate damage to the product or injury to persons during assembly.
2. Please do not tighten screws or bolts until the assembly is completed.
3. To level the chairs or table, before tightening all the screws, the chairs or table must be placed on a flat surface and then tighten the screws.
4. Please put all parts on a non-abrasive floor before assembly and follow the assembly steps to assemble your newly purchased product correctly and efficiently.

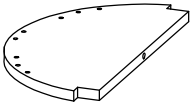
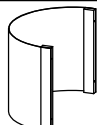
PARTS LIST			
NO.	DESCRIPTION	SKETCH	QTY
1	TOP PANEL		1 PC
2	BOTTOM PANEL		1 PC
3	SIDE PANEL - L		1 PC
4	SIDE PANEL - R		1 PC
5	CENTER PANEL - L		1 PC
6	CENTER PANEL - R		1 PC
7	BACK PANEL - L/R		2 PCS
8	BACK PANEL		1 PC

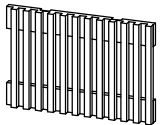
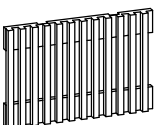







PARTS LIST			
NO.	DESCRIPTION	SKETCH	QTY
9	SHELF PANEL		1 PC
10	SEMICIRCLE PANEL		4 PCS
11	SEMICIRCLE		2 PCS
12	SEMICIRCLE SUPPORT		6 PCS
13	SLIDING DOOR - L		1 PC
14	SLIDING DOOR - R		1 PC

# ASSEMBLY INSTRUCTIONS









ITEM NUMBER : T3512W-40

COLLECTION NAME : BRAX

## HARDWARE LIST

NO.	DESCRIPTION	SKETCH	QTY
A1	MINIFIX CAM Ø9/16" x 1/2"		8 PCS
A2	MINIFIX BOLT M6 x 1-1/4"		8 PCS
A3	MINI FIX CAP Ø11/16" x 3/16"		8 PCS
B	WOOD DOWEL M8 x 1-3/16"		20 PCS
C	CSK C/W SCREW M6 x 2"		8 PCS
D	ALLEN KEY M4 x 2-3/4"		1 PC
E	C.B SCREW M3 x 1/2"		16 PCS
F	C.B SCREW M3.5 x 5/8"		20 PCS
G	C.B SCREW M4 x 1"		8 PCS

## HARDWARE LIST

NO.	DESCRIPTION	SKETCH	QTY
H	C.B SCREW M4 x 1-1/2"		32 PCS
I	SHELF SUPPORT 9/16" x 3/16"		4 PCS
J1	STUD 192 11/16" x 11/16"		12 PCS
J2	STUD SCREW 11/16" x Ø3/16"		12 PCS
K1	U 480 ROLLER UP 2-3/16" x 1-1/4"		4 PCS
K2	U480 ROLLER DOWN 2-3/8" x 1-1/2"		4 PCS
L	METAL LEG - 7-7/8" x Ø1"		5 PCS
M	STICKER Ø9/16"		8 PCS

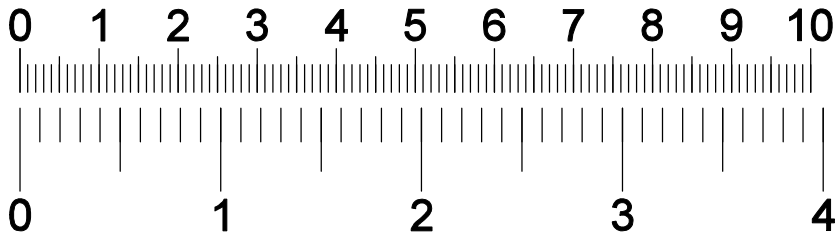

## HARDWARE DIMENSIONS VERIFICATION TOOL

**STEP 1 :** Insert hardware minifix (A1) onto panel (3), (4), (5) and (6). Insert hardware minifix (A2) onto panel (1).  
Insert hardware wood dowel (B) onto panel (3), (4), (5), (6) and (10).  
\*\*Attention : DO NOT OVER-TIGHTEN THE BOLTS.

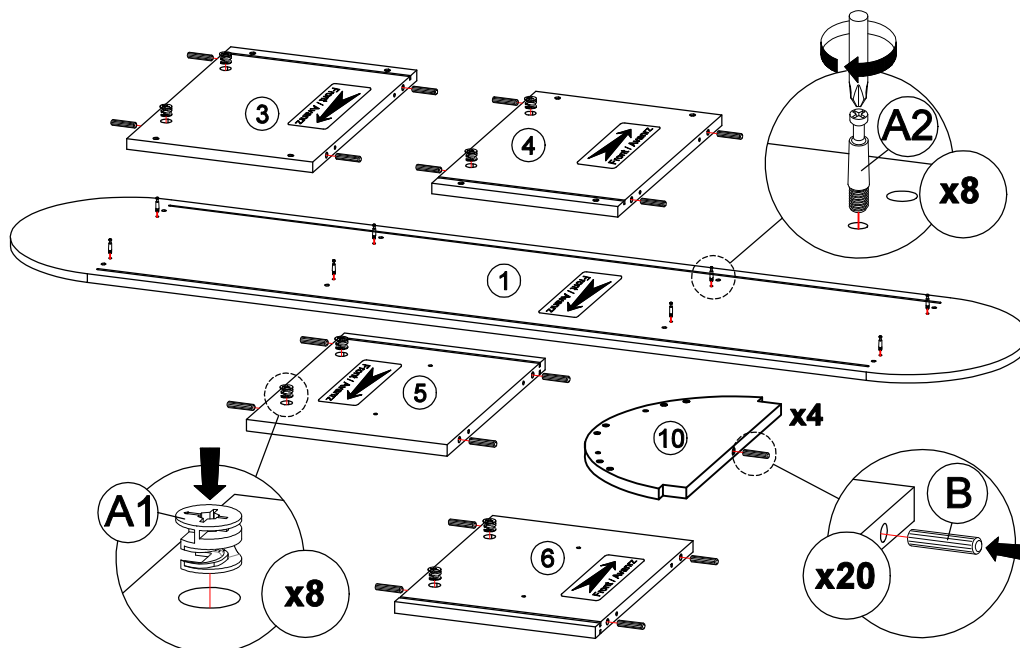

**STEP 2 :** Attach panel (10) with panel (12) by using hardware screws (H).

**\*\*Attention :** DO NOT OVER-TIGHTEN THE SCREWS.

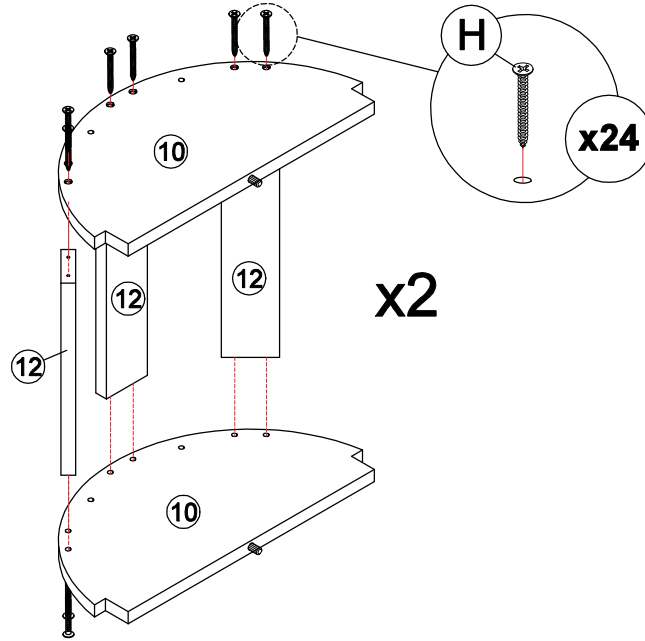

**STEP 3 :** Attach panel (3) and (4) to panel (10).

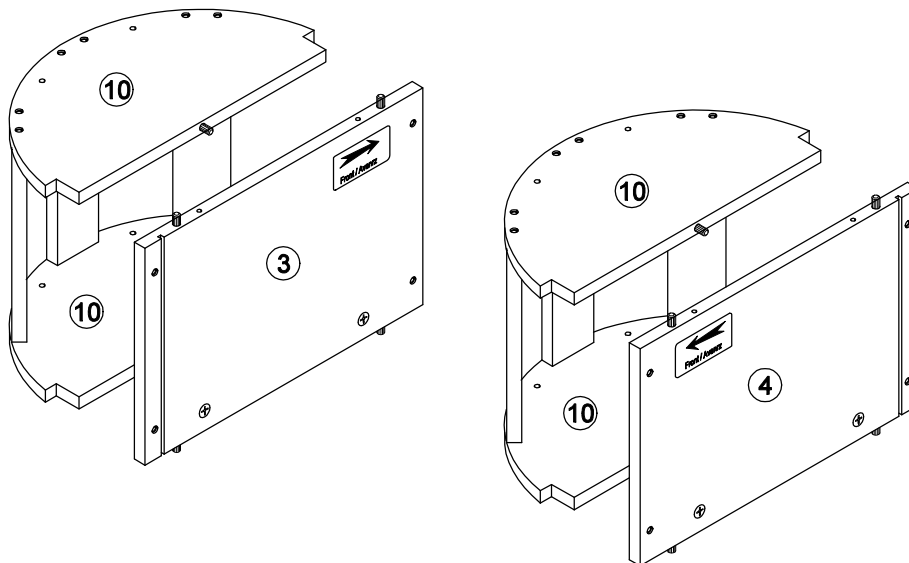

**STEP 4 :** Attach panel (1) to panel (3), (4), (5) and (6). Insert all hardware minifix (A2) into minifix (A1). Rotate all minifix (A1) until tight. Apply minifix (A3) onto all minifix (A1).  
**\*\*Attention :** DO NOT OVER-TIGHTEN THE BOLTS.

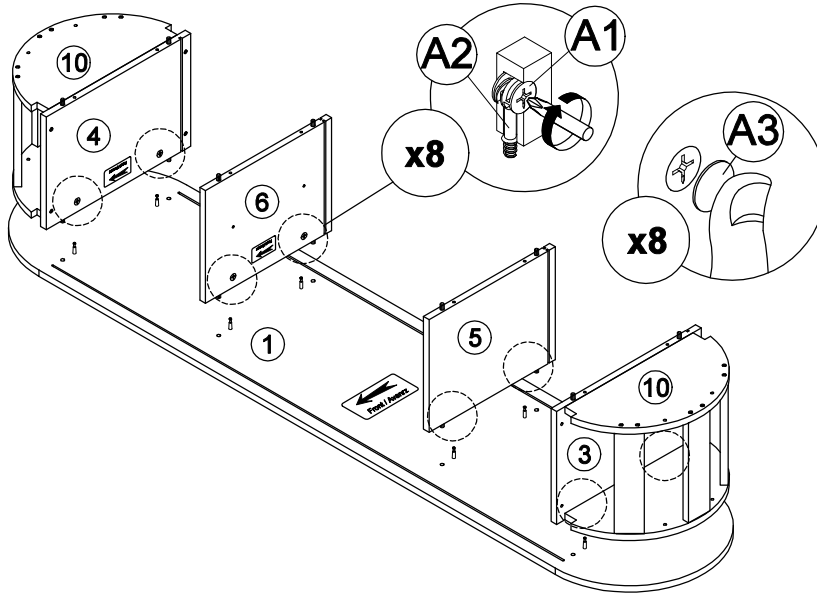

**STEP 5 :** Insert panel (7) along the slot into between panel (3) and (5) then between panel (4) and (6). Insert panel (8) along the slot into between panel (5) and (6).

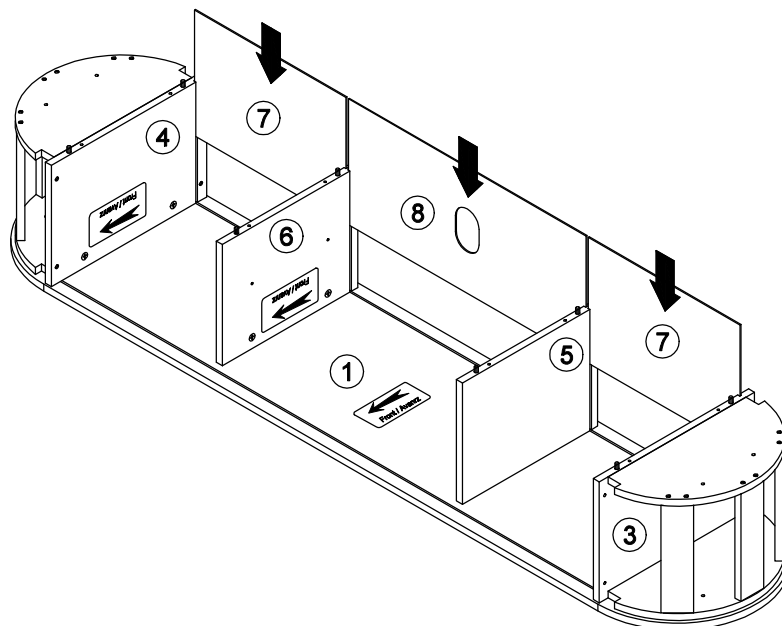

**STEP 6 :** Assemble panel (2) to panel (3), (4), (5) and (6) by using allen key (D) with hardware screws (C).  
**\*\*Attention :** DO NOT OVER-TIGHTEN THE SCREWS.

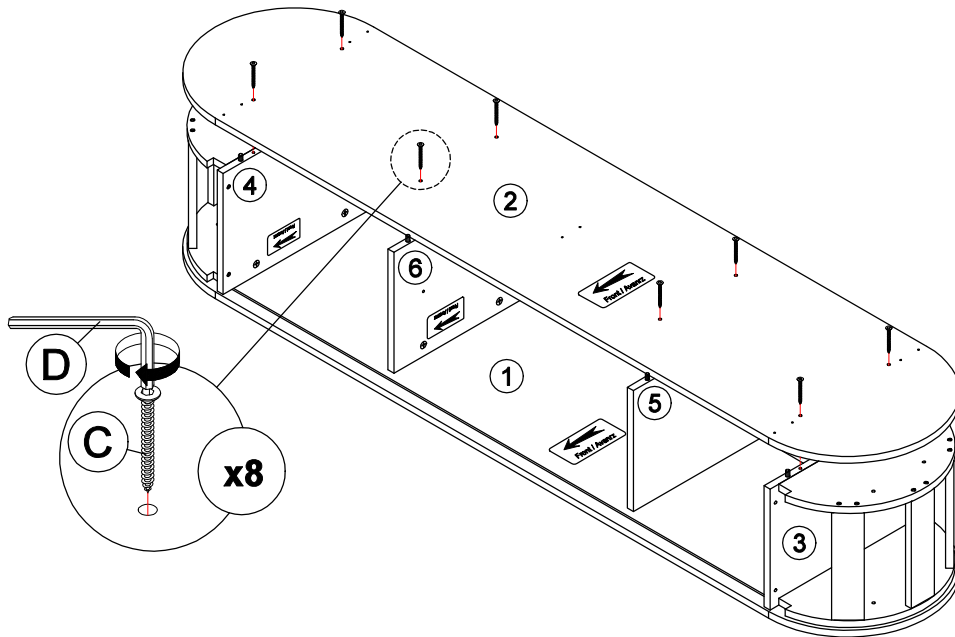

**STEP 7 :** Assemble panel (10) to panel (1) and (2) by using hardware screws (G).  
**\*\*Attention :** DO NOT OVER-TIGHTEN THE SCREWS.

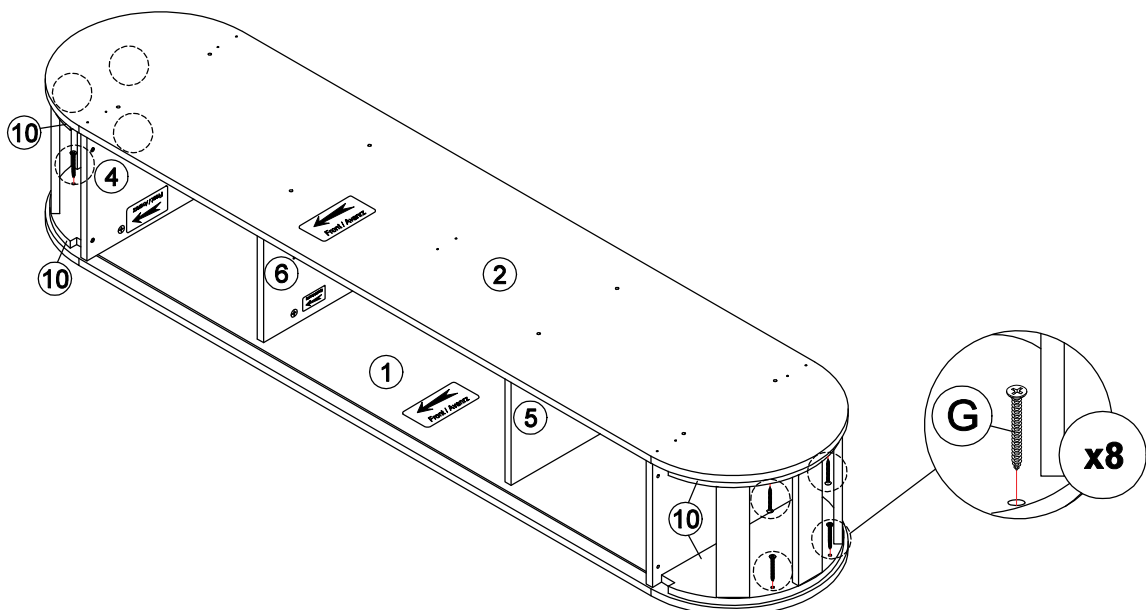

**STEP 8 :** Assemble panel (11) to panel (3) and (4) by using hardware screws (H).

Stick hardware (M) to hardware (H).

**\*\*Attention :** DO NOT OVER-TIGHTEN THE SCREWS.

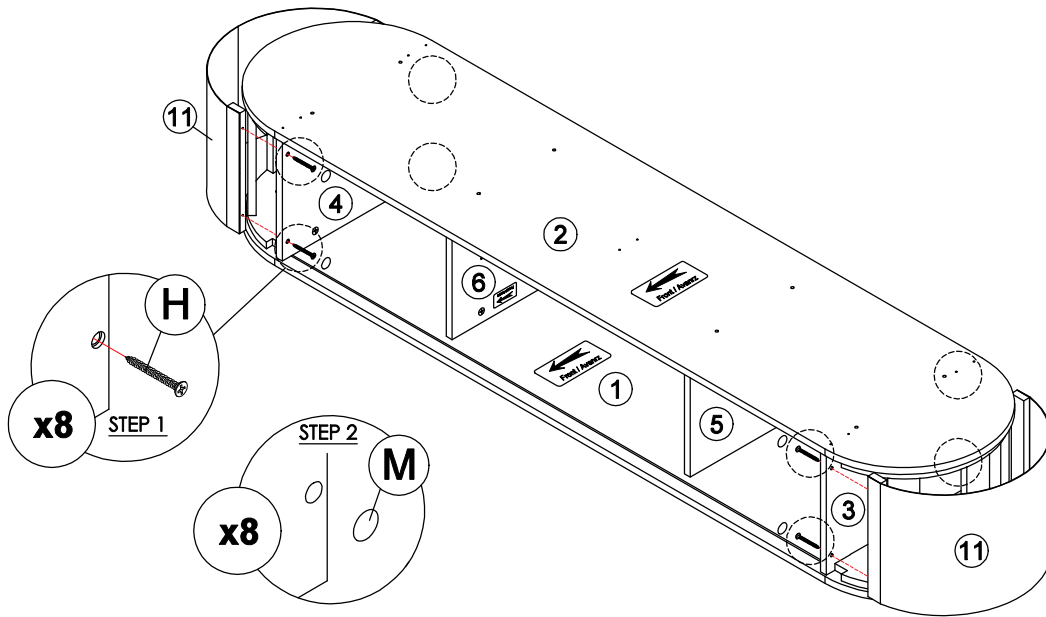

**STEP 9 :** Fix hardware (L) onto panel (2) by using hardware screw (F).

**\*\*Attention :** DO NOT OVER-TIGHTEN THE SCREWS.

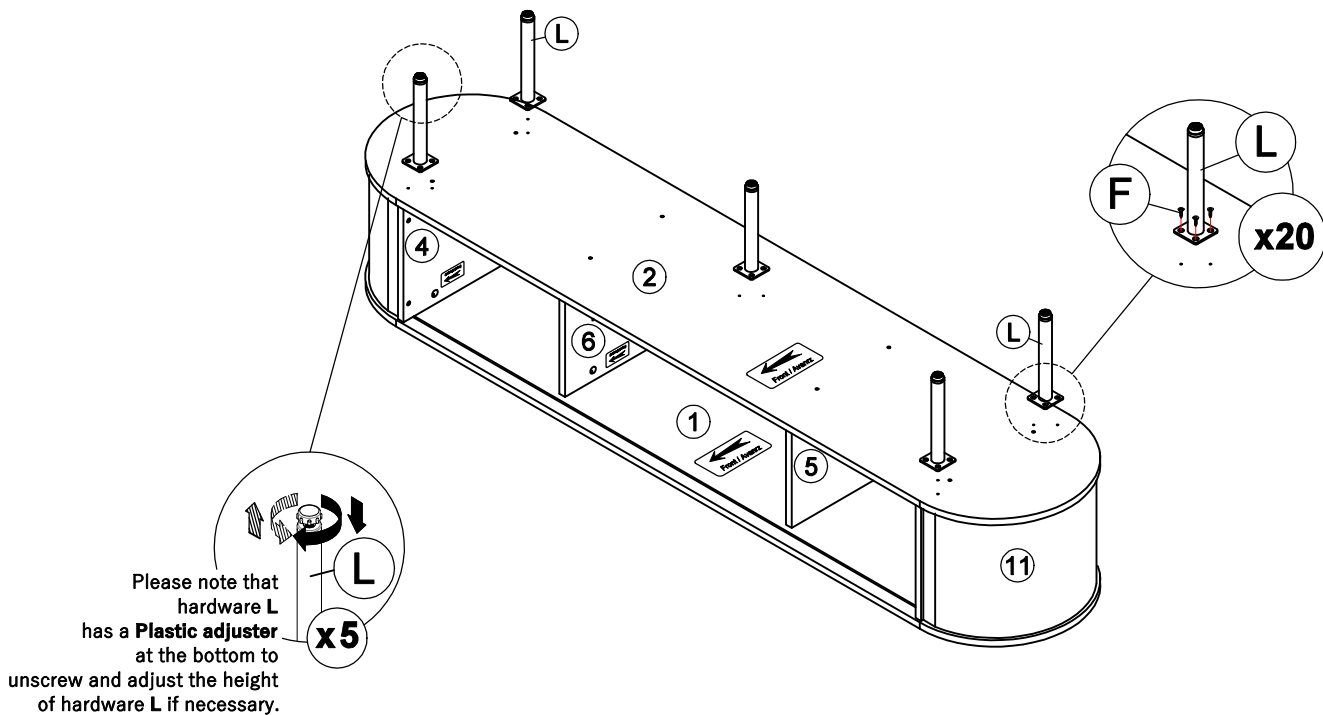

**STEP 10 :** Insert hardware (J1) into slot at panel (1), (2), (3), (4), (5) and (6) .

Assemble hardware (J1) by using hardware (J2).

**\*\*Attention : DO NOT OVER-TIGHTEN THE SCREWS..**

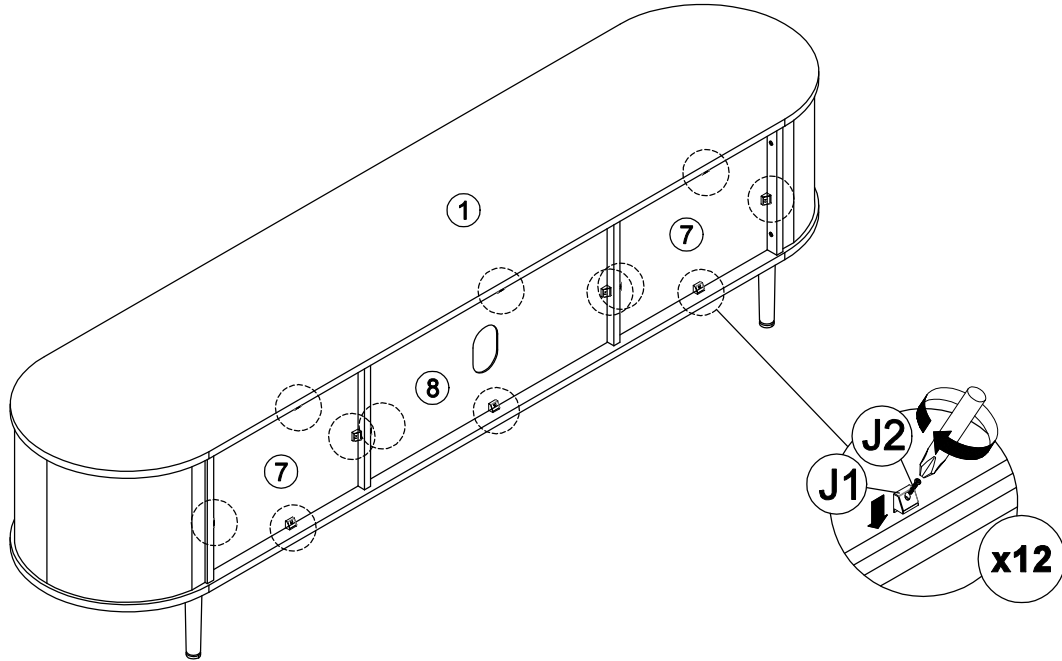

**STEP 11 :** Insert hardware (I) onto mounting position panel (5) and (6) by hand.

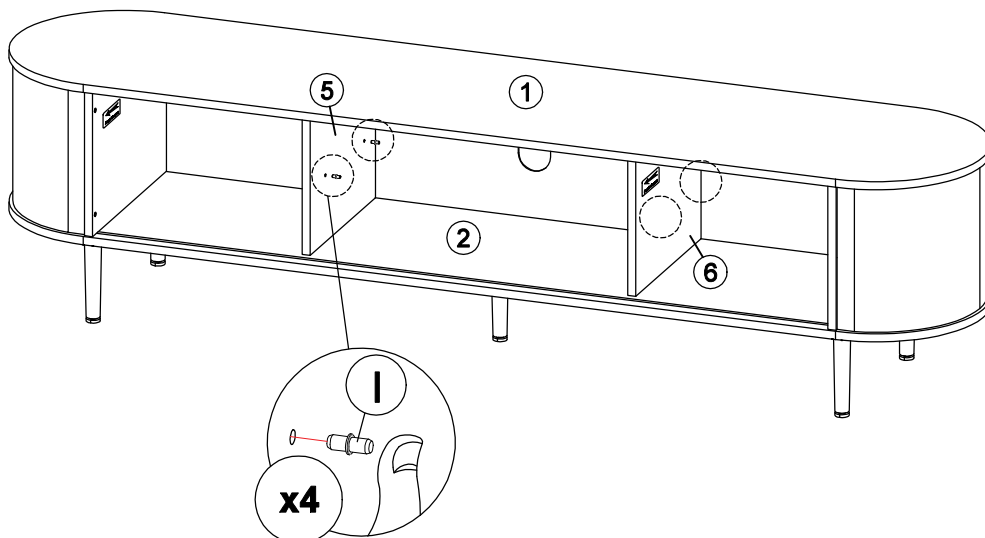

**STEP 12 :** Insert panel (9) into between panel (5) and (6).

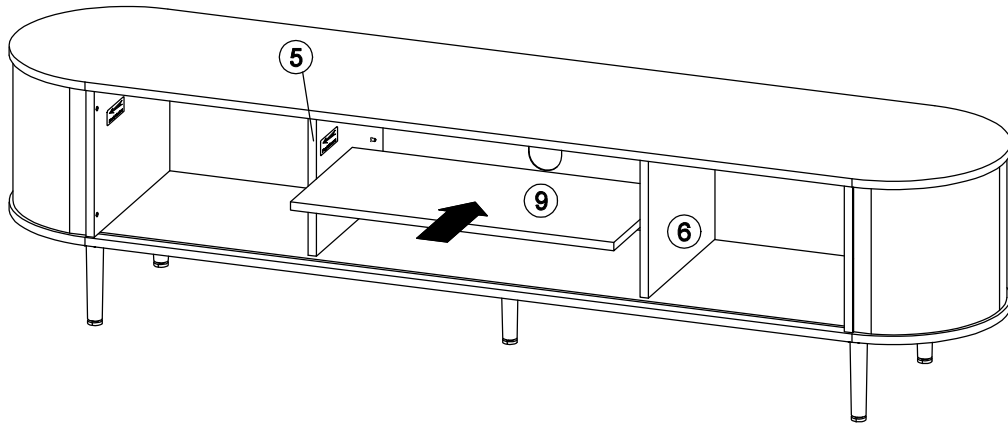

**STEP 13 :** Assemble hardware (K1) and (K2) to panel (13) and (14) with hardware (E).

**\*\*Attention :** DO NOT OVER-TIGHTEN THE SCREWS.

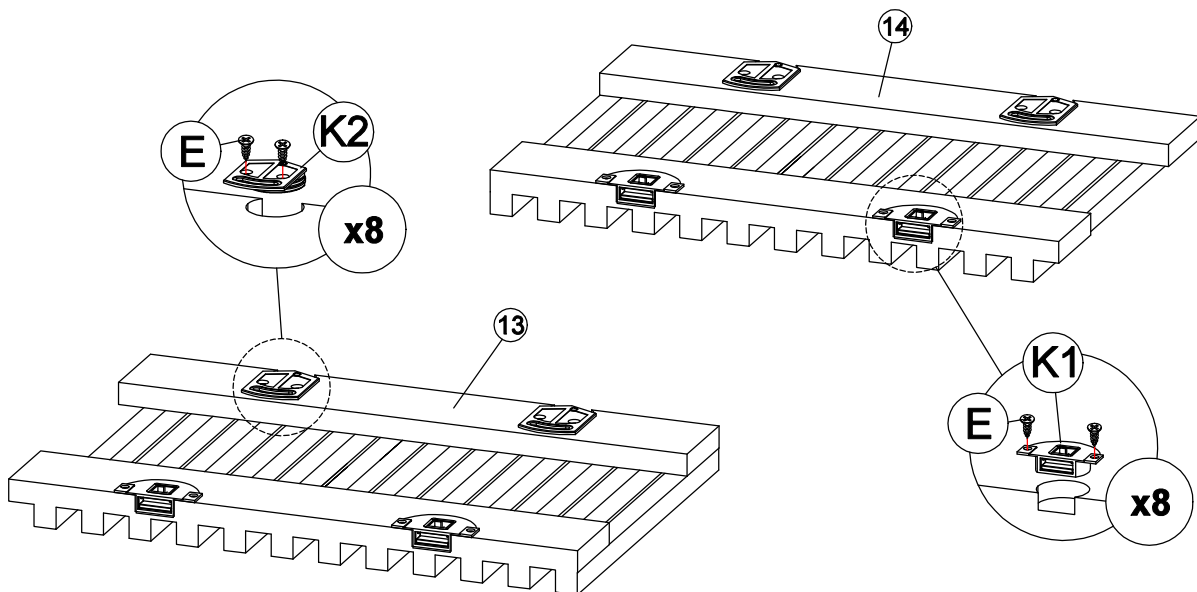

**STEP 14 :** Put the panel (13) and (14) in place along the railways.

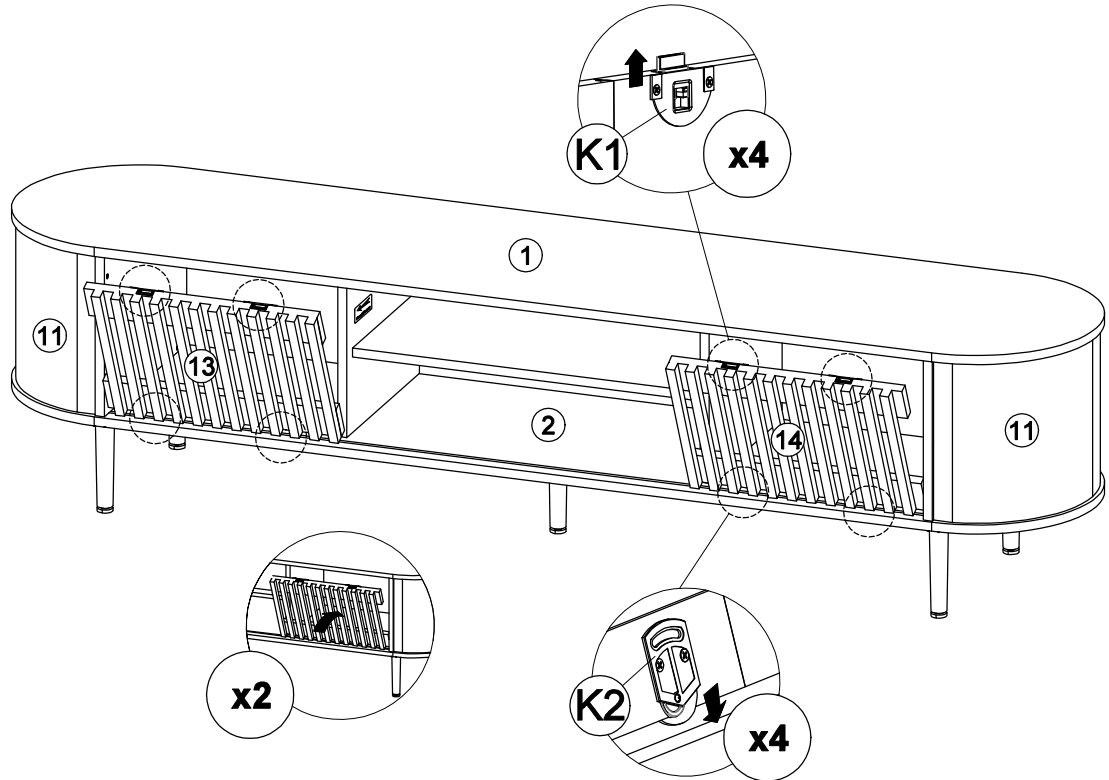

**ASSEMBLY COMPLETED**

