











ASSEMBLY INSTRUCTIONS

DESCRIPTION : DRESSER

Thank you for purchasing this quality product. Be sure to check all packing material carefully for small Hardware which may have some loose inside the carton during shipment. Identify and count all Hardware. Identify and count all Hardware and compare with the Hardware List Below.

PARTS LIST				HARDWARE LIST				
No.	Description	Sketch	Q'ty	No.	Description	Sketch	Size	Q'ty
A	Dresser		1pc	1	Allen Bolt		Ø5/16"x38mm	8pcs
B	Front Bun Foot		2pcs	2	Spring Washer		Ø5/16"	8pcs
C	Right Back Bun Foot		1pc	3	Flat Washer		Ø5/16"x19mm	8pcs
D	Left Back Bun Foot		1pc	4	Allen Key		4mm	1pc
E	Support Leg		1pc	5	Tipping Restraint			1pc

Step 1:

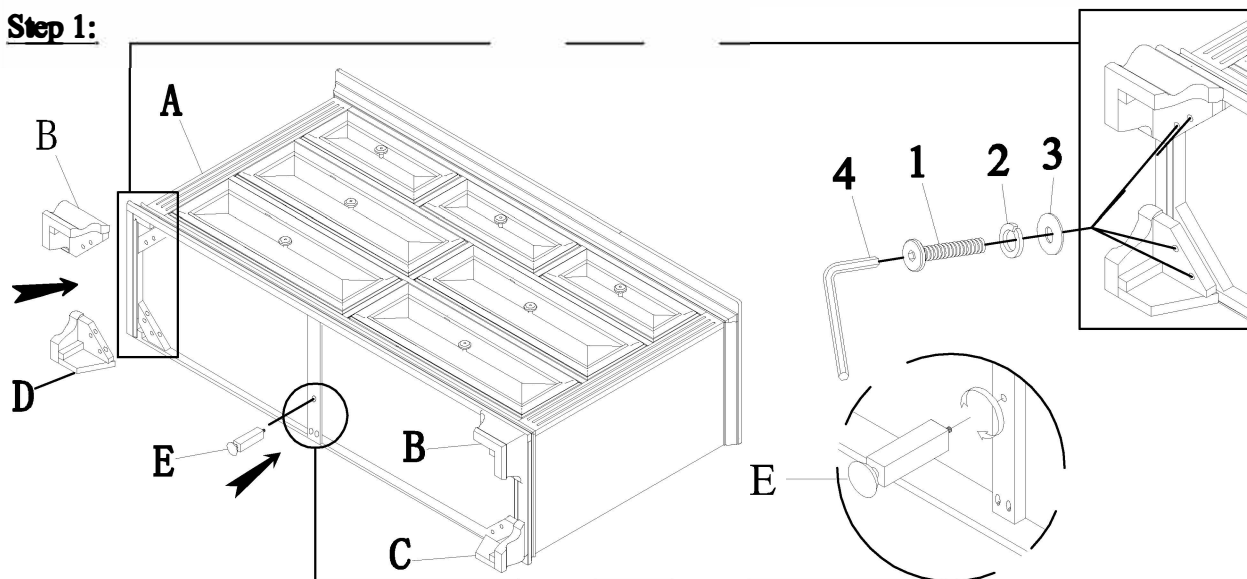

ASSEMBLY INSTRUCTIONS

DESCRIPTION : DRESSER

Thank you for purchasing this quality product. Be sure to check all packing material carefully for small Hardware which may have some loose inside the carton during shipment. Identify and count all Hardware. Identify and count all Hardware and compare with the Hardware List Below.

Step 2:

