

70" SIX DOOR ACCENT CABINET

INSTALLATION & ASSEMBLY

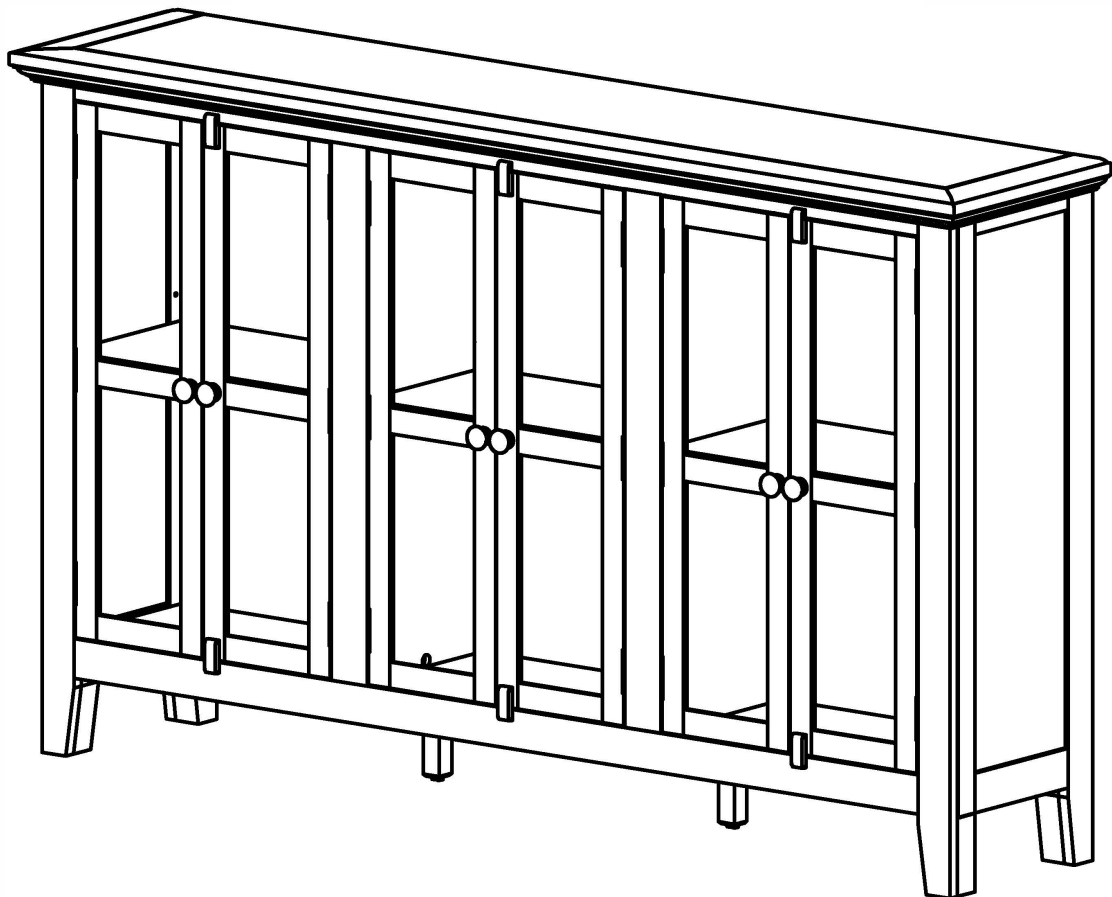

ASSEMBLY INSTRUCTIONS & PARTS IDENTIFICATION RUSTIC SHORES 6 DOORS ACCENT CABINET - SCRIMSHAW

Parts key

No	Code	Qty	Description	No	Code	Qty	Description
1	T	1 pc	Top	9	LSFED	3 pcs	Left Side Facing End Door
2	BS	1 pc	Bottom Shelf	10	RSFED	3 pcs	Right Side Facing End Door
3	FF	1 pc	Front Frame	11	SPH	6 pcs	Side Panel Hinge
4	LSFSP	1 pc	Left Side Facing Side Panel	12	DH	18 pcs	Door Hinge
5	RSFSP	1 pc	Right Side Facing Side Panel	13	ML	2 pcs	Middle Leg
6A	VPL	1 pc	Vertical Partition Left	14	LV	6 pcs	Leveler
6B	VPR	1 pc	Vertical Partition Right	15	DC	3 pcs	Door Catch
7	S	3 pcs	Shelf	16	ATTK	1 set	Anti-Tip Kit
8	BP	3 pcs	Back Panel				
8A	DT	6 pcs	Door Tab				

Hardware Kit

No	Code	Qty	Description	No	Code	Qty	Description
17	SP	12 pcs	Shelf Pin	19	WS	12 pcs	Wood Screw
18	KWS	6 pcs	Knob w/ Screw	20	WD	2 pcs	Wood Dowel

PLEASE NOTE: Assembly requires two people. Follow directions step by step.

Step:01

Carefully lay out all pieces on a padded surface to prevent damage. Take extra care when removing the door unit from the carton. Doors must be secured so they will not fall open.

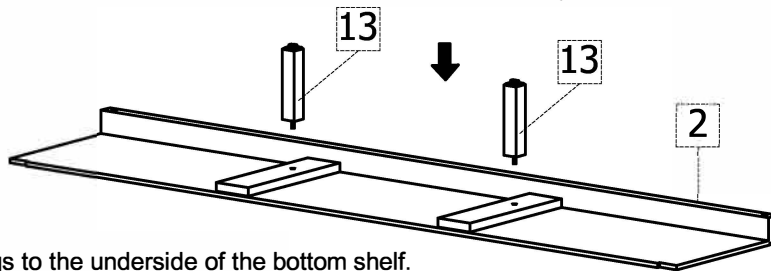

-Attach the middle support legs to the underside of the bottom shelf.

Step:02

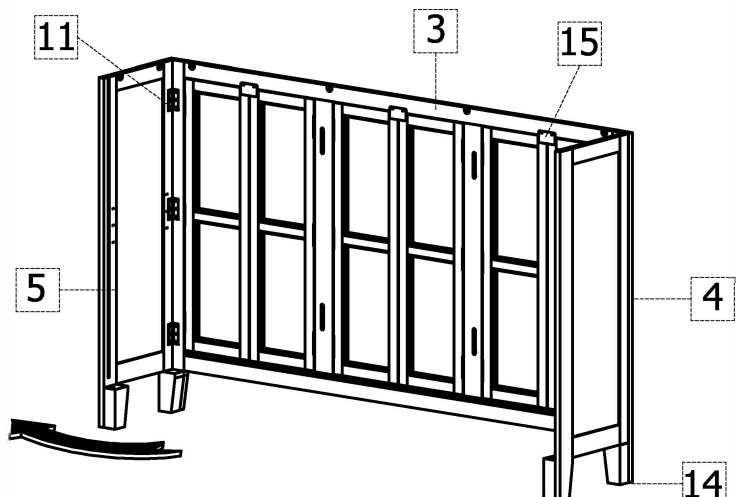

- With the help of the second person, open the front frame assembly positioning the two side panels of the cabinet 90° perpendicular to the cabinet frame.

ASSEMBLY INSTRUCTIONS & PARTS IDENTIFICATION RUSTIC SHORES 6 DOORS ACCENT CABINET - SCRIMSHAW

Step:03

- Insert the wood dowels into the rear leg support.

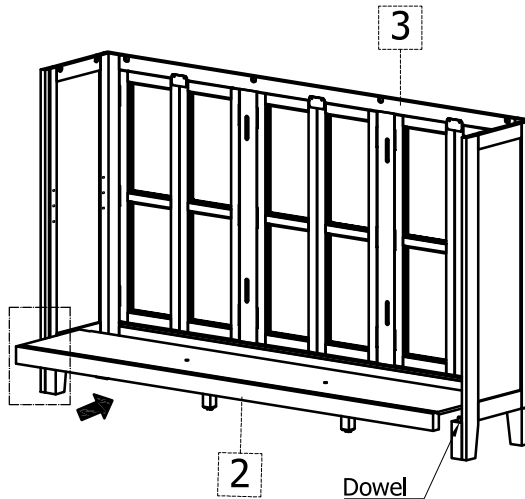
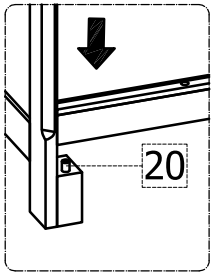

- Place the bottom shelf in position and lock into the wood dowels in the rear leg.

Step:04

-Insert the Vertical Partition by placing the tab on the panel into the receiver on the Front Frame and gently push down to lock into place. Make sure that the locking tab is in the opened position to insert into the bottom shelf.

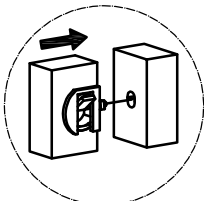
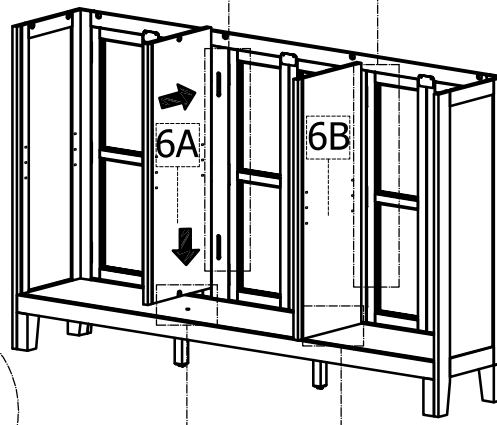

Tab in opened position

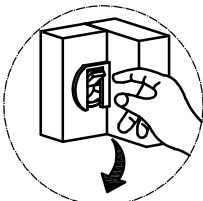

Pull tab down to lock

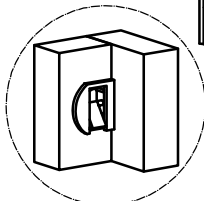

Tab in locked position

- Lock the tab (see diagram below) to secure the vertical panel to the bottom shelf

Step:05

- Carefully insert the back panels into place making sure that the lock tabs are in the open position on the bottom of the back panel.
- Once in place, lock the tabs on the bottom.

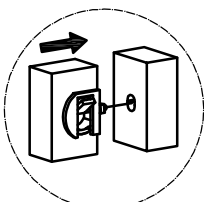
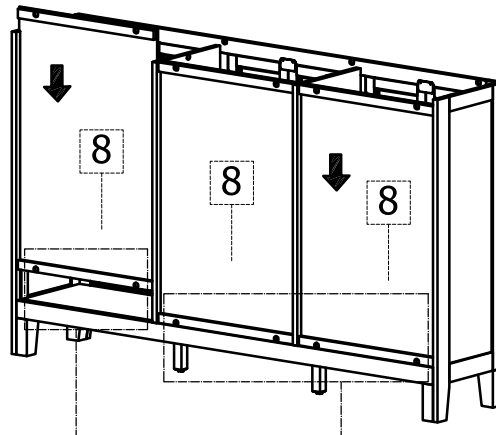

Tab in opened position

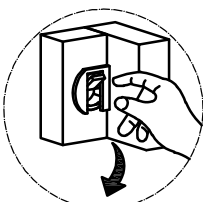

Pull tab down to lock

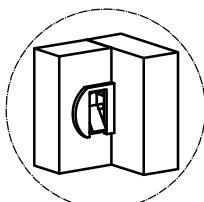

Tab in locked position

ASSEMBLY INSTRUCTIONS & PARTS IDENTIFICATION RUSTIC SHORES 6 DOORS ACCENT CABINET - SCRIMSHAW

Step:06

- Line up all the locking tabs in the open position
- With two people, carefully align the top in place making sure that the tab fits into the receiver portion on the top. Once firmly in place, lock the tabs.

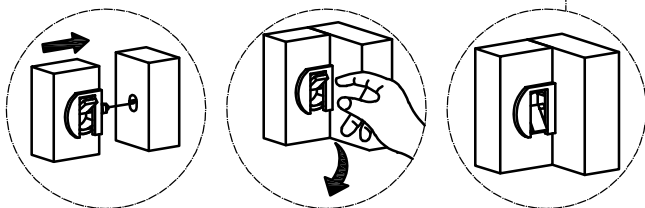

Tab in opened position Pull tab down to lock Tab in locked position

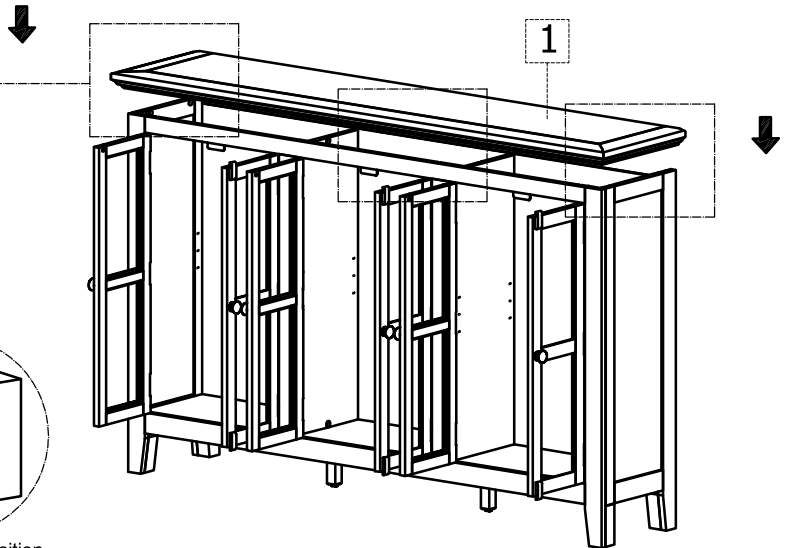

Step:07

- Install the shelves using the shelf pins. it is important to secure the shelf in place with the wood screws (See Diagram)
- Install the knobs as shown

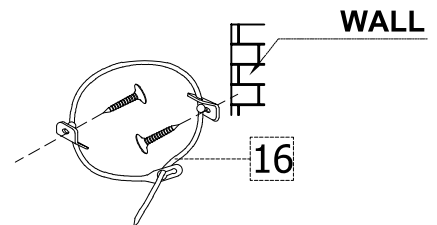
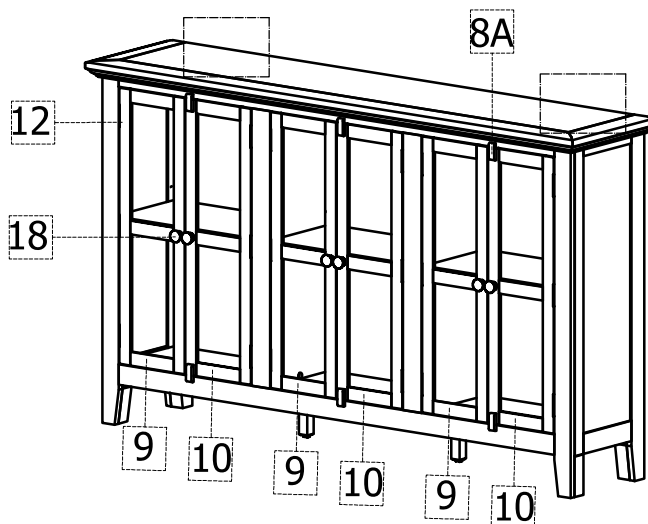
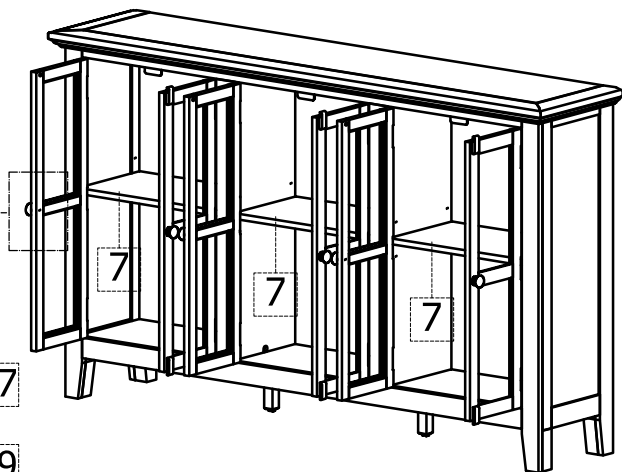
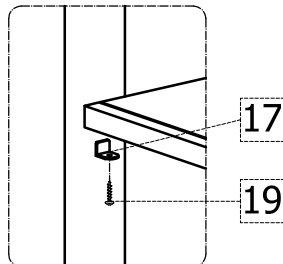
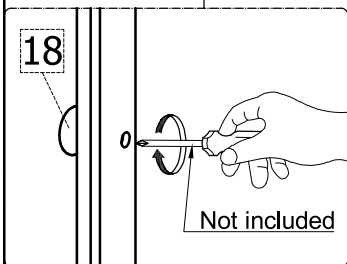

PLEASE NOTE :
To help prevent the possibility of tip-over, install the ANTI- TIP OVER restraint provided.