

BED SIZE QUEEN

ASSEMBLY INSTRUCTIONS



800 lb
362 Kg

MAX BED
WEIGHT





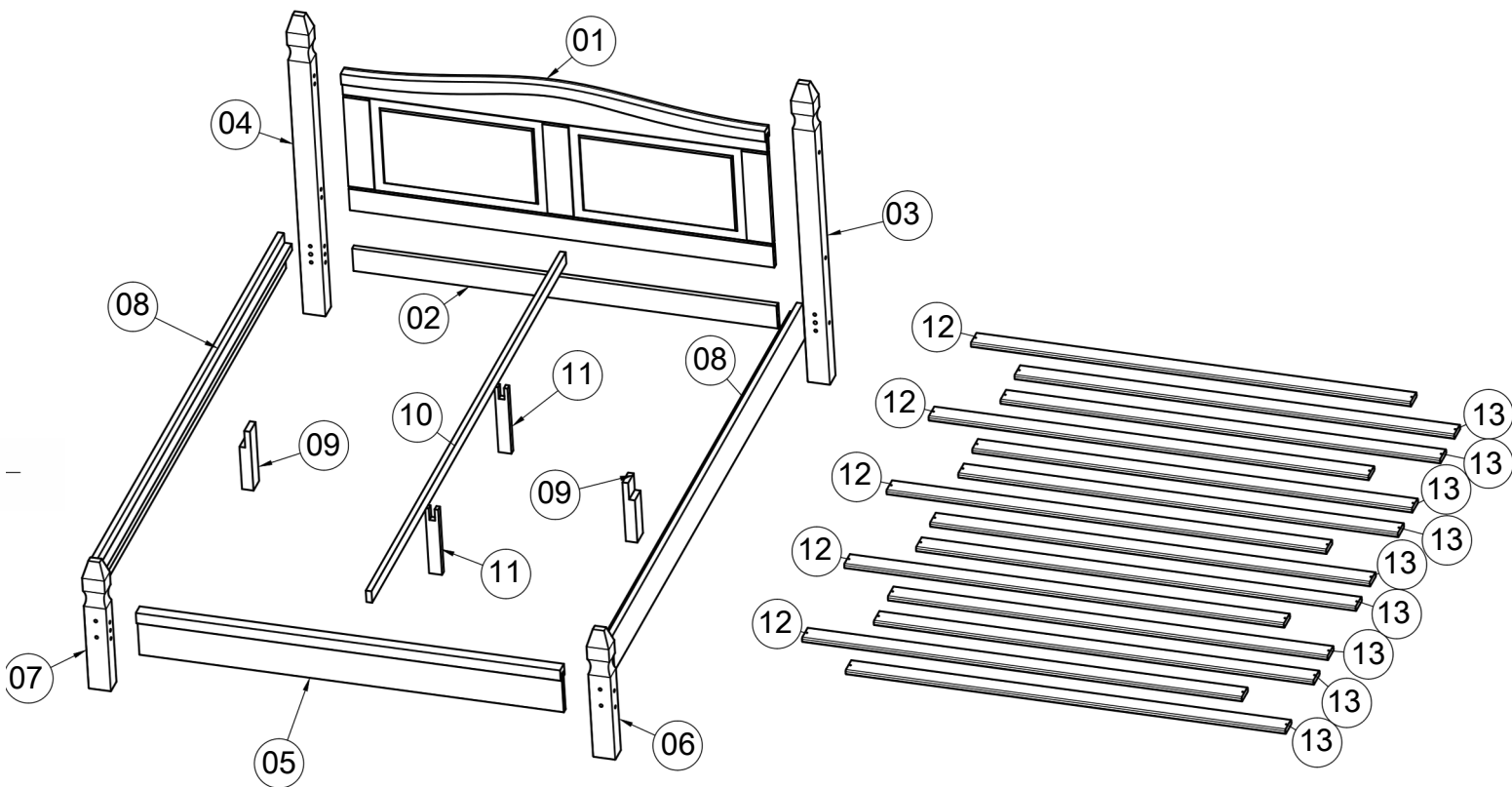









IMPORTANT
PLEASE READ BEFORE YOU CONTINUE FURTHER
FOR DOMESTIC USE ONLY
CARE AND MAINTENANCE

- After unpacking this product, please keep the original packaging in case it needs to be returned for any reason.
- Please ensure all fittings and parts are present before commencing with assembly.
- We recommend that you lay a blanket or sheet on the floor to avoid damage to both your floor and the product.
- We strongly recommend that you keep children away from your work area.
- Assemble this product as close to its final position as possible.
- Never drag or push products as this could cause damage to the joints making it inferior.
- Do not drag or push items across your furniture as this may cause the surface to scratch.
- Do not place this product next to radiator or in direct sunlight.
- Wood is a natural product and may expand if subjected to damp and may shrink or crack if subjected to heat. Therefore, it is recommended that room temperature is maintained, with no sudden temperature fluctuations.
- Make sure any spillage is wiped off immediately.
- Do not place hot or chilled items directly on to the surface, use a place mat or marking will occur.
- For general cleaning, use a soft cotton or micro fibre cloth and do not use detergents of any kind.
- Do not place on a wet or damp floor as staining may occur to your floor.
- From time to time, it may be necessary to tighten fittings; regular inspections should be carried out.

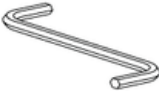

Please Note: The parts below have been stamped with the part number to help identify them during assembly

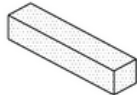
Part Number	Part Description	Quantity	Carton
01	Headboard Panel	1	2/2
02	Headboard Crossbeam	1	2/2
03	Right Headboard Post	1	1/2
04	Left Headboard Post	1	1/2
05	Footboard Panel	1	2/2
06	Right Footboard Post	1	1/2
07	Left Footboard Post	1	1/2
08	Siderails	2	1/2
09	Siderail Support	2	1/2
10	Centre Support Rail	1	1/2
11	Centre Support Leg	2	1/2
12	Slats (3 Holes)	5	2/2
13	Slats (2 Holes)	9	2/2

A	+1	 10 x 50 mm	14	H	 GLUE	01
B		 1/4" x 110 mm	04	I	+1 	04
C	+1		04	J	+1  3.5 x 30 mm	33
D		 7 x 120 mm	10	K	+1  4.0 x 35 mm	08
E		 7 x 100 mm	04	L	+1  4.0 X 16 mm	10
F			01	M		02
G		(SPACER) (WOODEN) 	02	N	 7 x 80mm	02



* Use of power tools to assemble this product will invalidate any claim and damage this product making it unsafe !!!
* Please assemble on a clean soft surface to avoid damage.



* Please check contents and read the instructions before commencing assembly.
* Assemble this product following the enclosed instructions carefully.
* Please take care to avoid damaging panels during assembly.

TOOLS REQUIRED

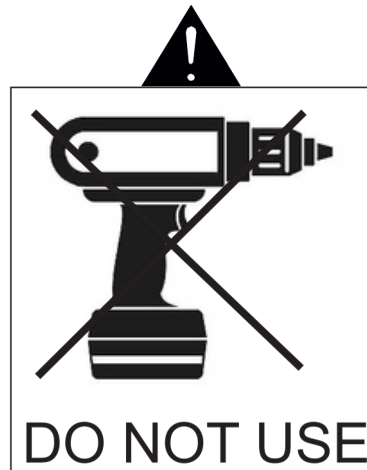
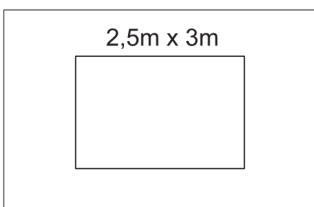
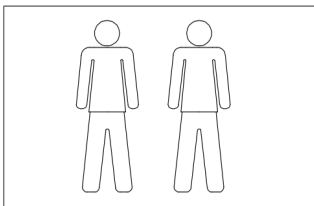
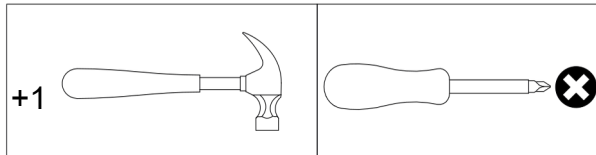
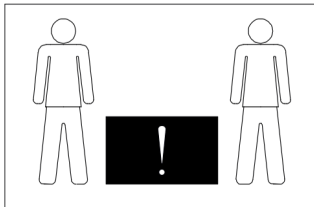



STEP 1

TOOLS REQUIRED:

PARTS REQUIRED:

01	Headboard Panel	x1	05	Footboard Panel	x1
02	Headboard Crossbeam	x1			

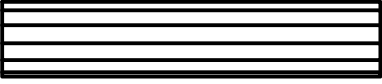
HARDWARE REQUIRED:

A	 10 X 50 mm	x10
H	 GLUE	x1

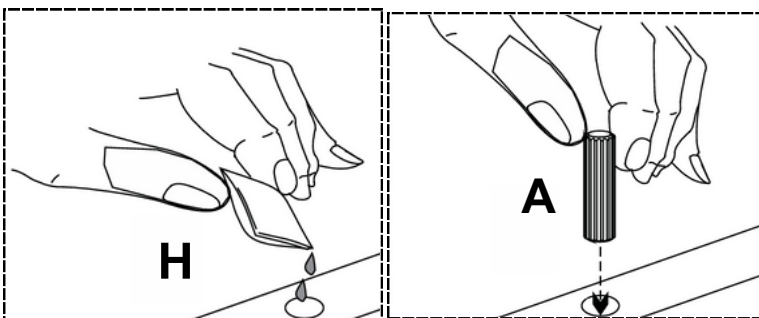
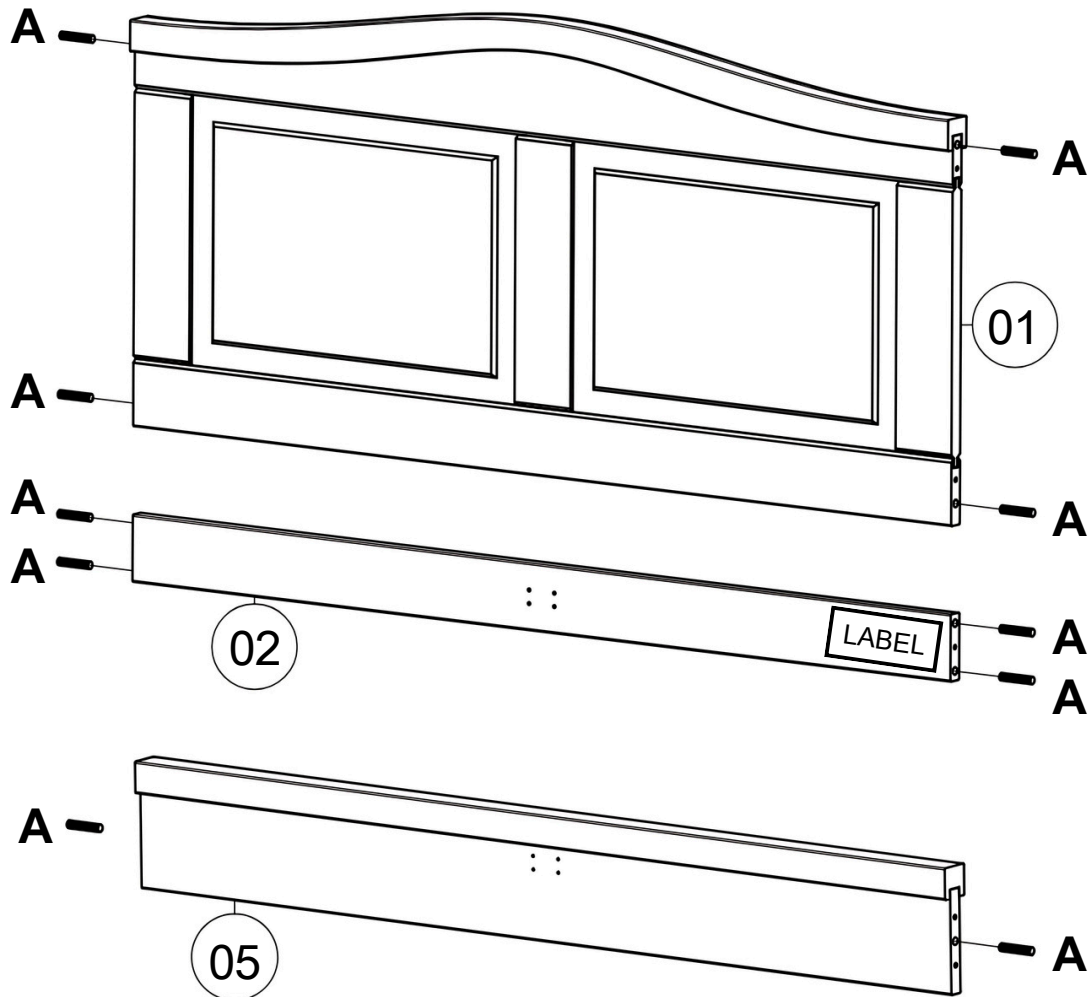

Glue must be added to the dowel holes on parts 01, 02 and 05.

STEP 2

TOOLS REQUIRED:

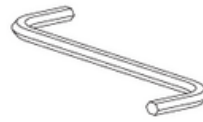

PARTS REQUIRED:

01	Headboard Panel	x1	03	Right Headboard Post	x1
02	Headboard Crossbeam	x1	04	Left Headboard Post	x1

HARDWARE REQUIRED:

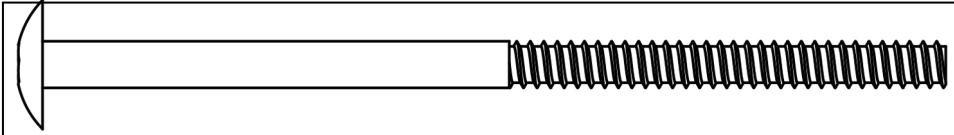
D		7 X 120 mm	x6
---	--	------------	----

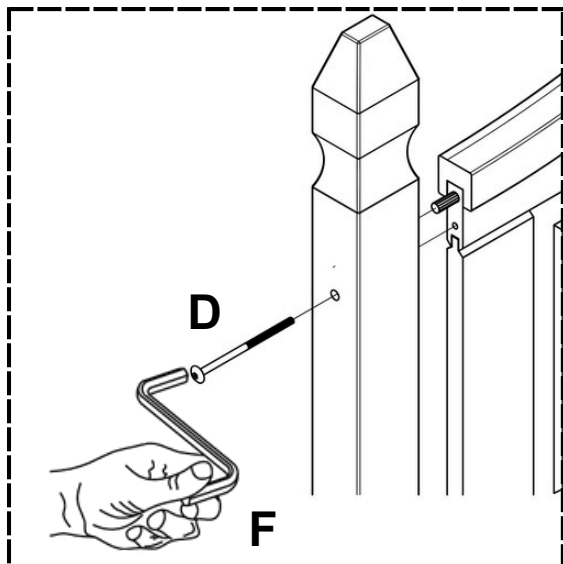
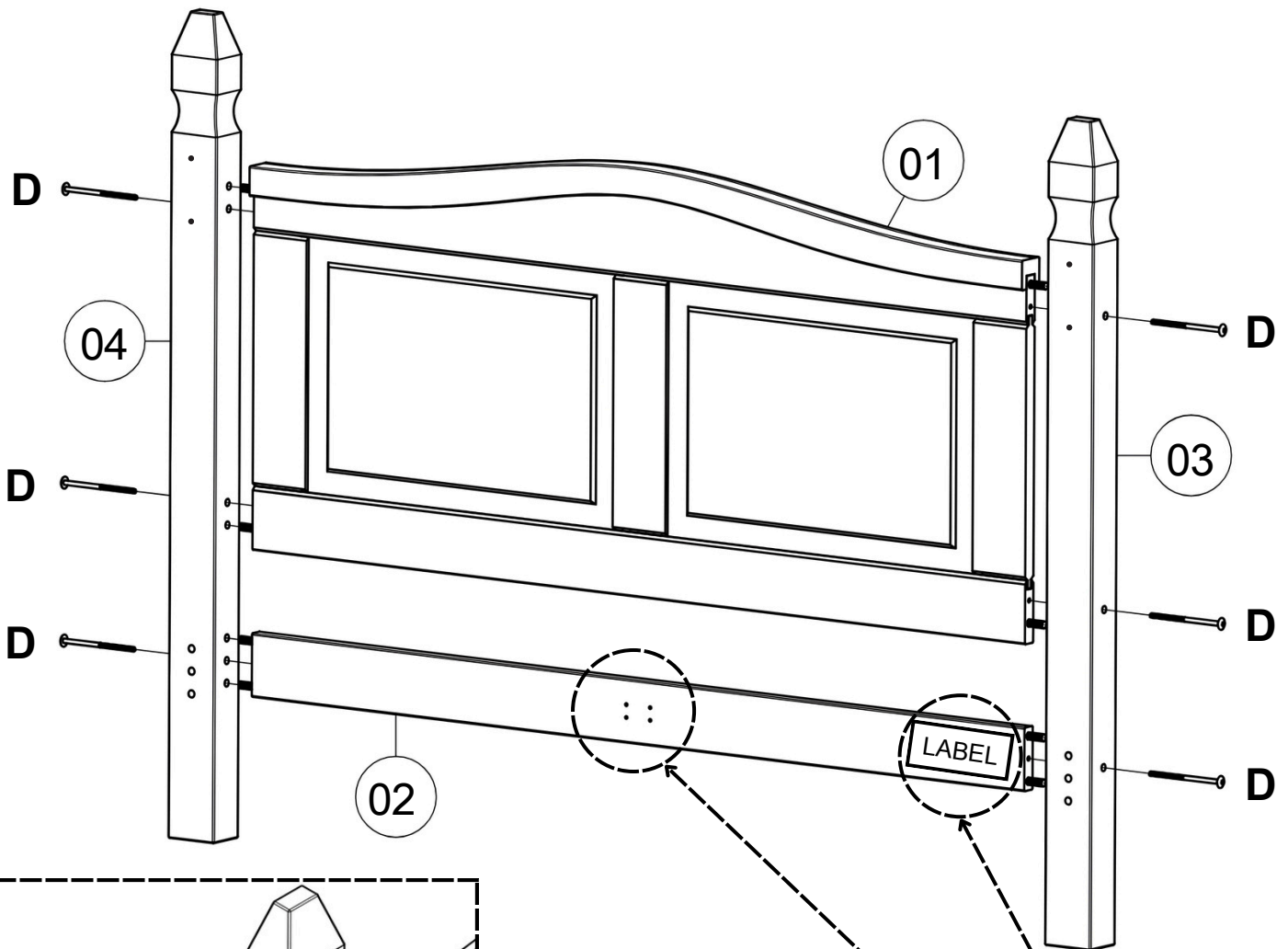

Please note the pre-marked holes and the label position.

STEP 3

TOOLS REQUIRED:

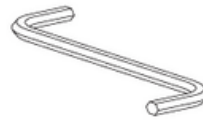

PARTS REQUIRED:

05	Footboard Panel	x1	07	Left Footboard Post	x1
06	Right Footboard Post	x1			

HARDWARE REQUIRED:

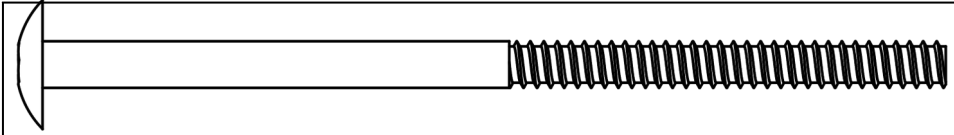
D		7 X 120 mm	x4
---	--	------------	----

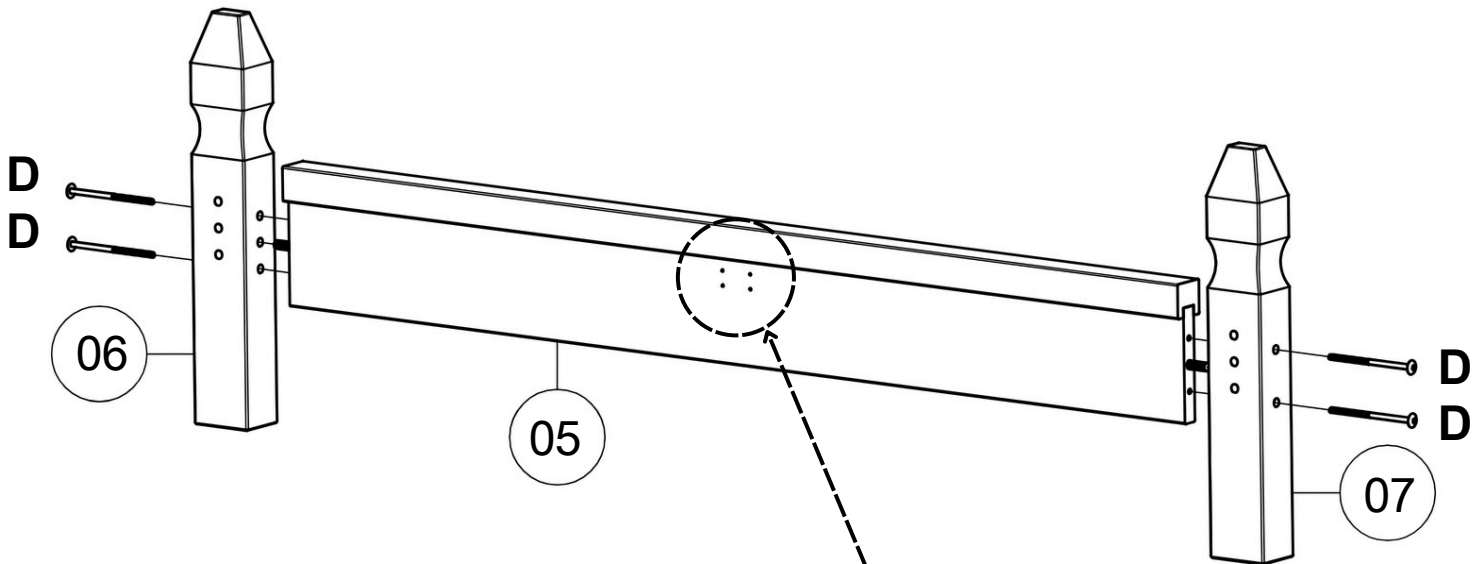

Please note the pre-marked holes!

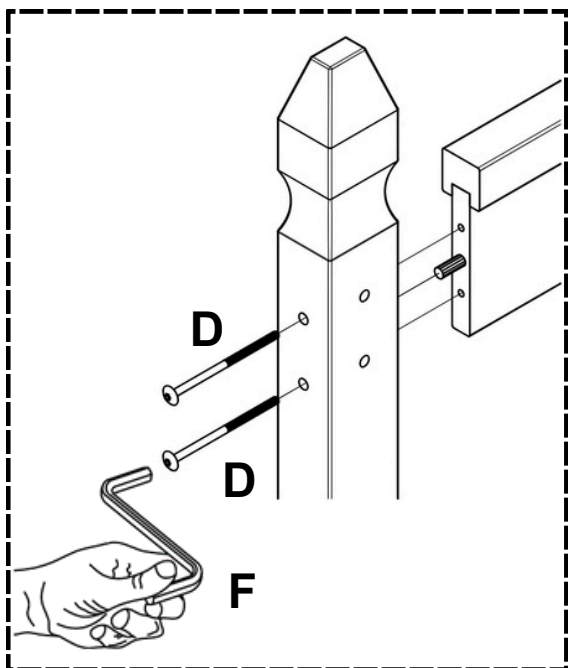



STEP 4

TOOLS REQUIRED:

PARTS REQUIRED:

08	Siderail	x2
----	----------	----

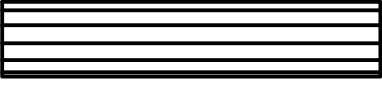
HARDWARE REQUIRED:

A	 10 X 50 mm	x4
H	 GLUE	x1

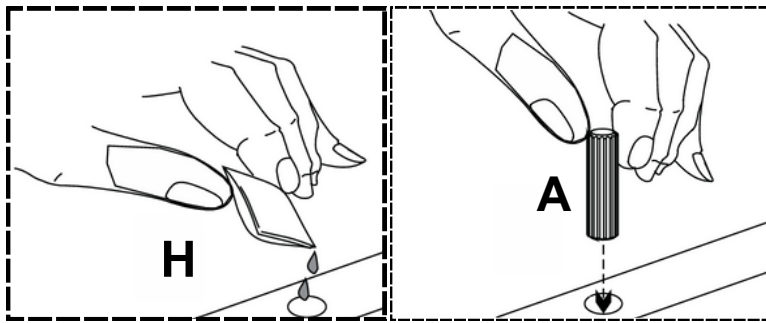
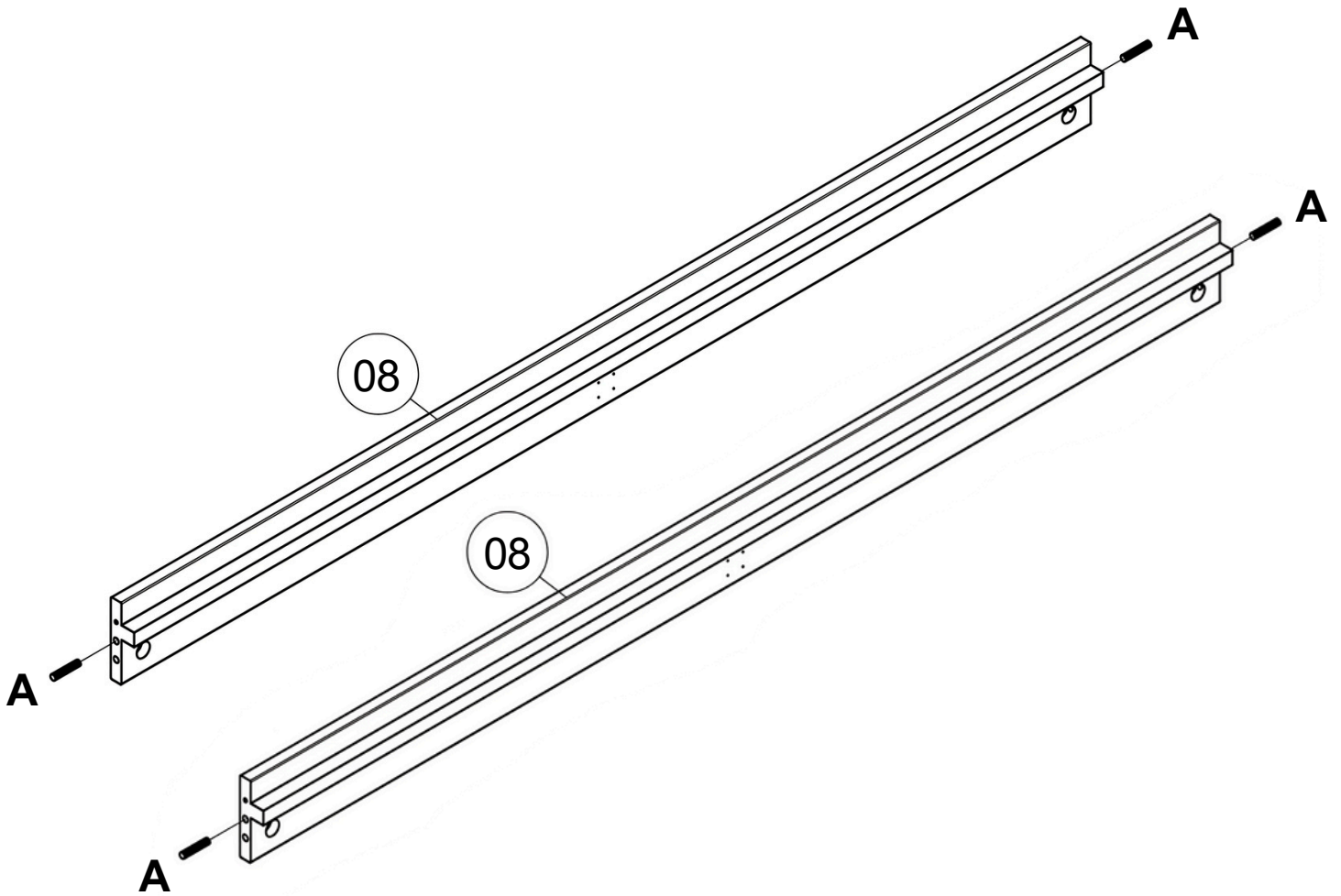

Glue must be added to the dowel holes on parts 08.

STEP 5

TOOLS REQUIRED:

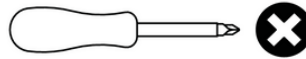

PARTS REQUIRED:

08	Siderail	x2	09	Siderail Support	x2
----	----------	----	----	------------------	----

HARDWARE REQUIRED:

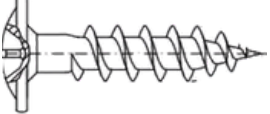
K		4.0 x 35mm	x8
---	---	------------	----

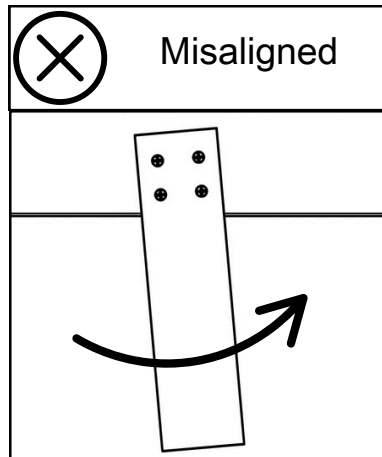
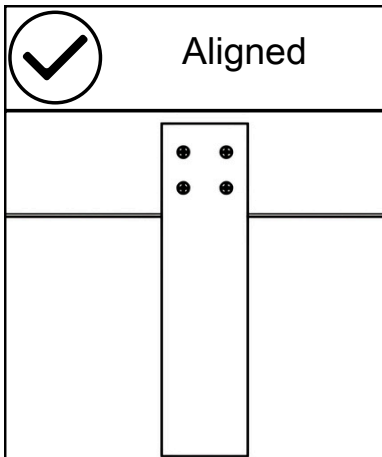
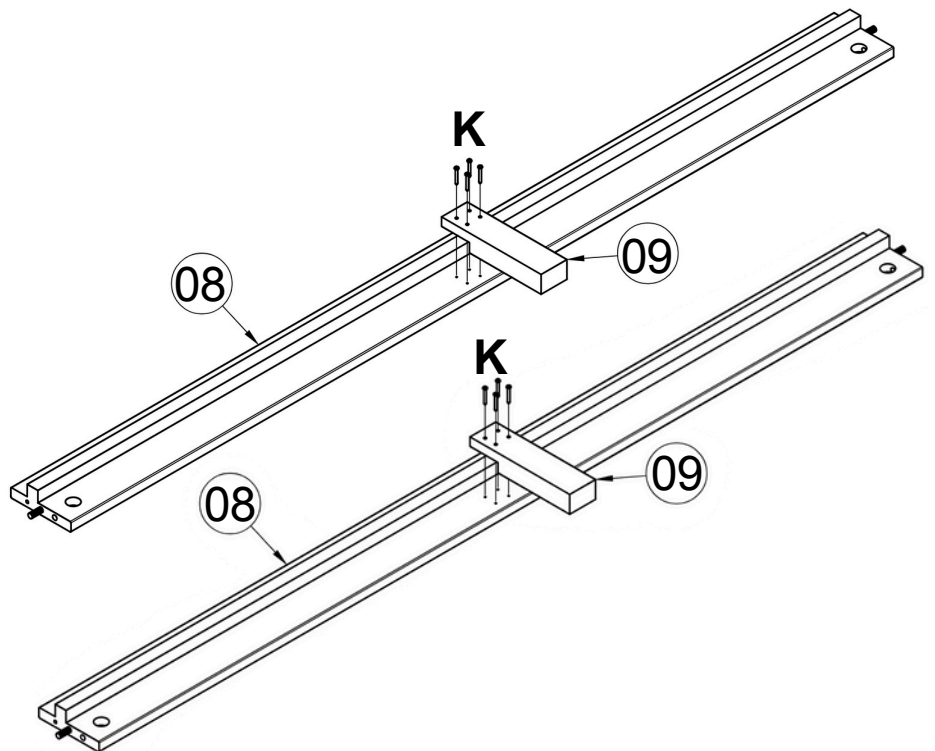
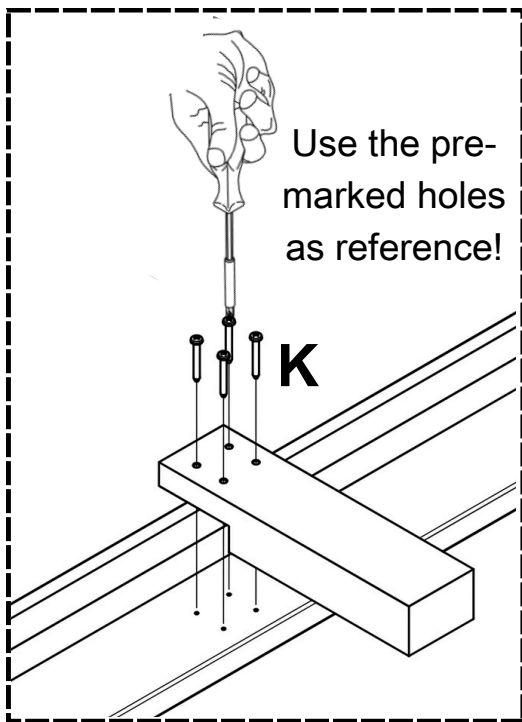

The Siderail Support (9) must be mounted perpendicular to the siderail (8). Make sure the part is not misaligned. Mount the Siderail Support (9) with its cut-out face flush against the underside of the siderail (8).

STEP 6

TOOLS REQUIRED:

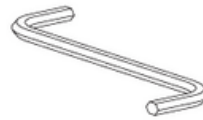

PARTS REQUIRED:

HARDWARE REQUIRED:

B		1/4 X 110 mm	x4
C			x4
E		7 X 100 mm	x4

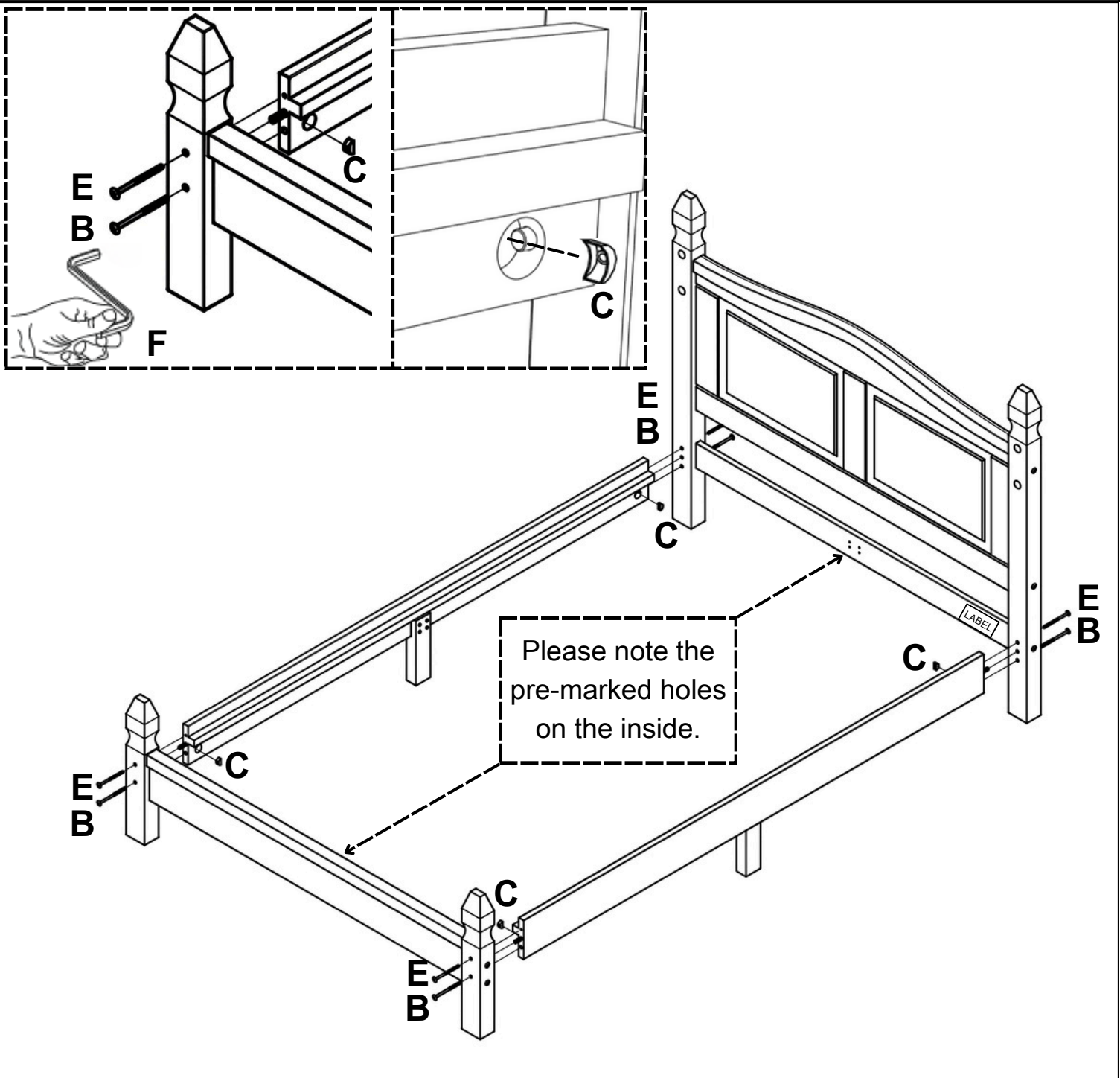



STEP 7

TOOLS REQUIRED:



PARTS REQUIRED:

HARDWARE REQUIRED:

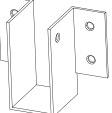
I		x4
L	 4.0 x 16 mm	x8
M		x2

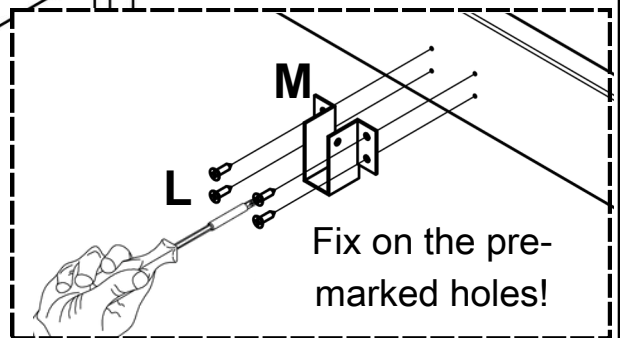
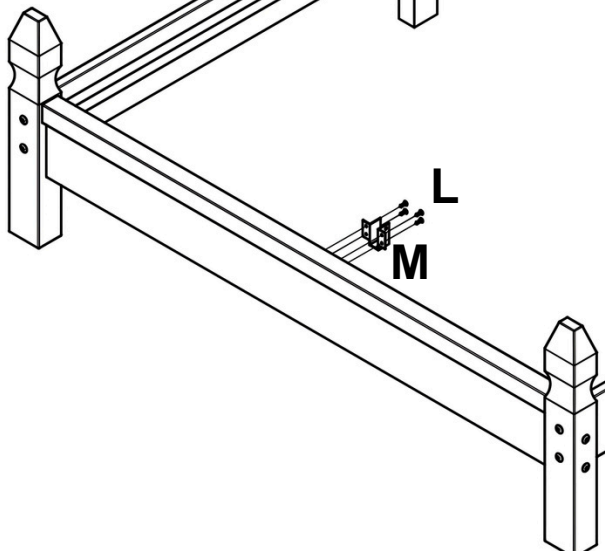
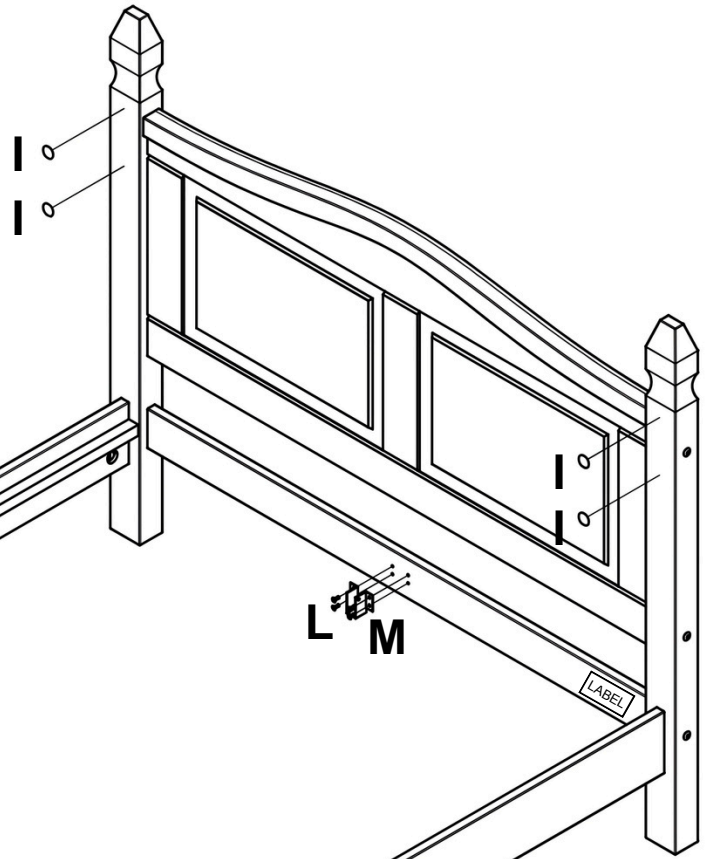
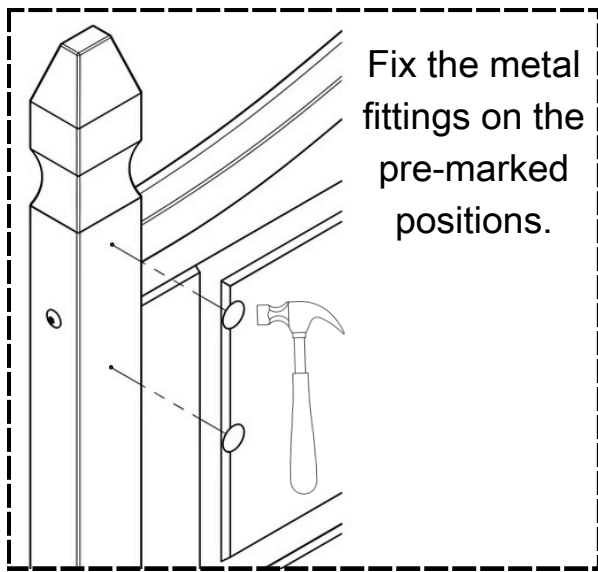

STEP 8

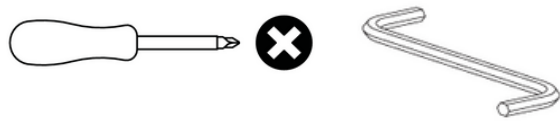

TOOLS REQUIRED:



PARTS REQUIRED:

10	Centre Support Rail	x1
11	Centre Support Leg	x2

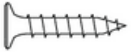
HARDWARE REQUIRED:

L	 4.0 x 16 mm	x2
N	 7 x 80 mm	x2

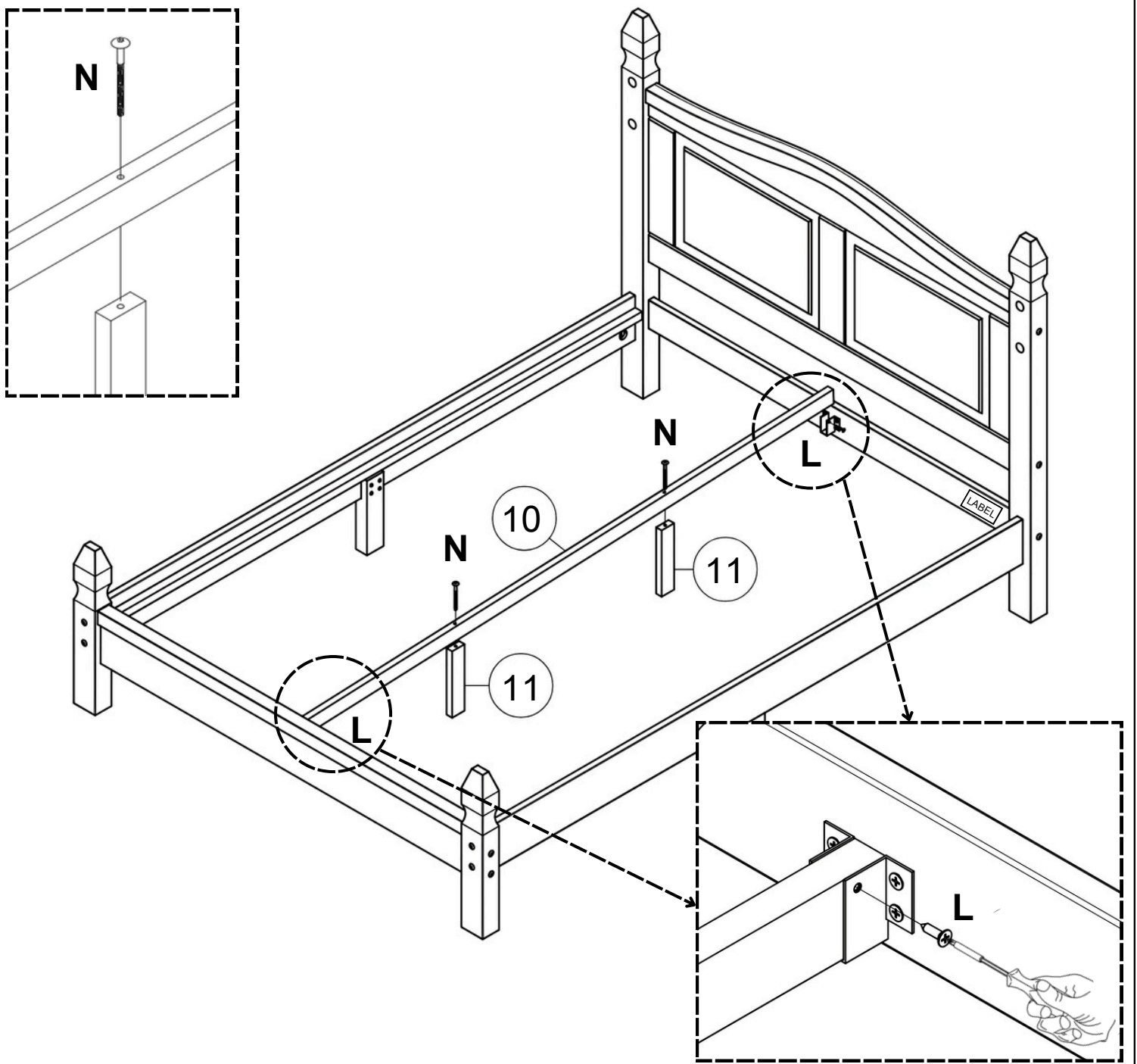

STEP 9

TOOLS REQUIRED:

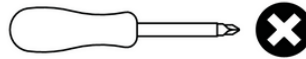

PARTS REQUIRED:

12	Slats (3 Holes)	x5	13	Slats (2 Holes)	x9
----	-----------------	----	----	-----------------	----

HARDWARE REQUIRED:

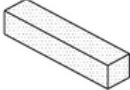
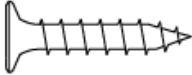
G	(SPACER) (WOODEN)		X2
J		3.5 x 30 mm	x33

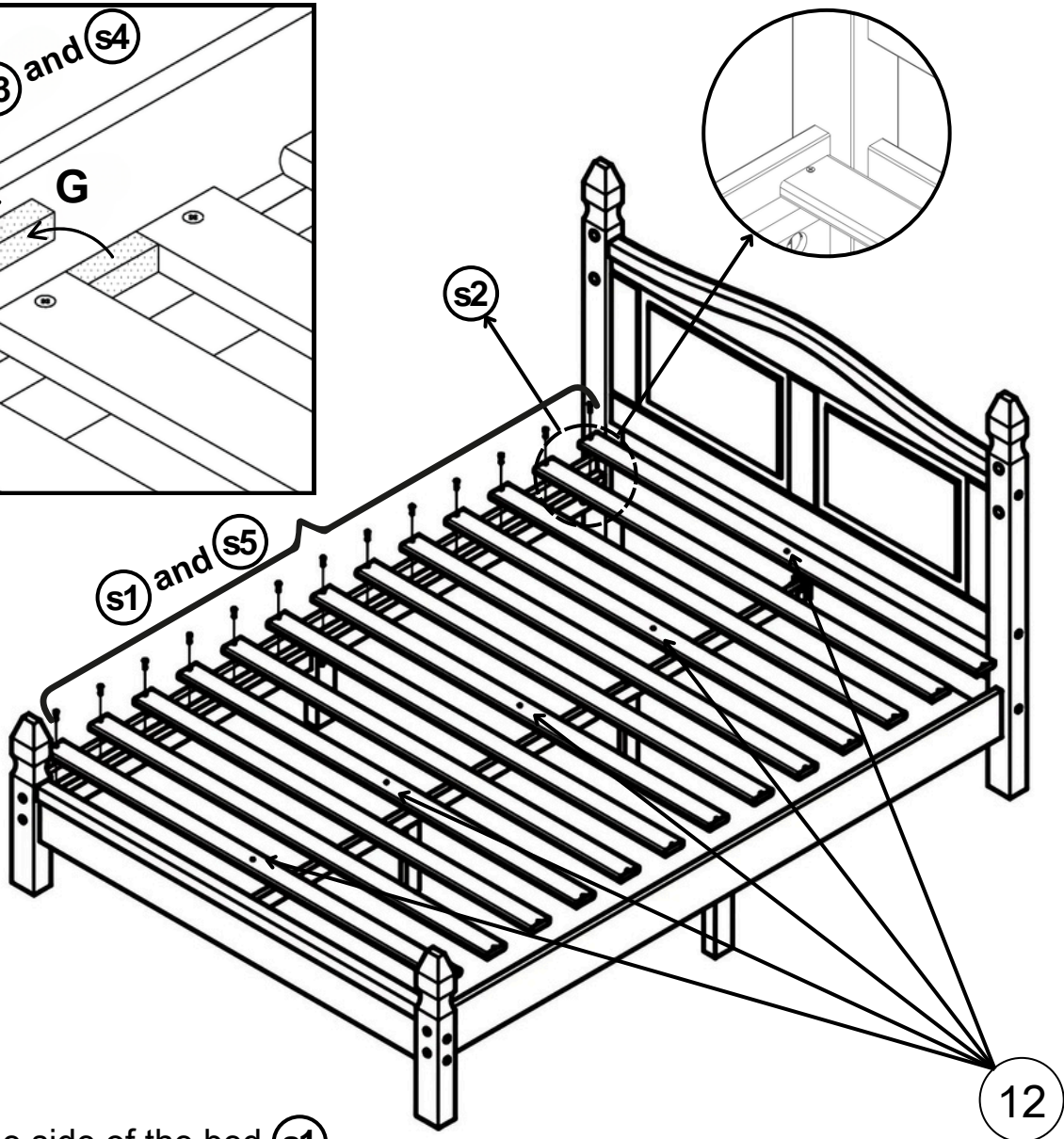
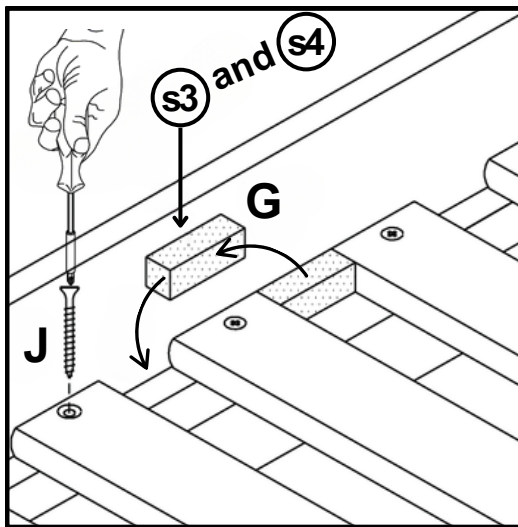

- Start on one side of the bed. (s1)
- Place the first slat adjacent to the headboard (Part 12). (s2)
- Use the spacer as shown to ensure correct spacing between the slats. (s3)
- Continue placing all the slats one by one, using the spacer. (s4)
- Fix all the slats to the first side rail (Part 8). (s5)

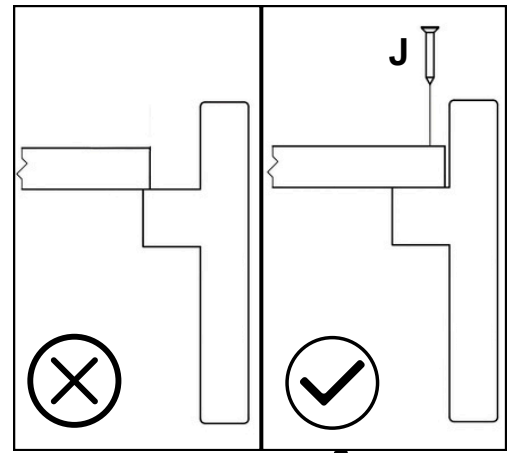
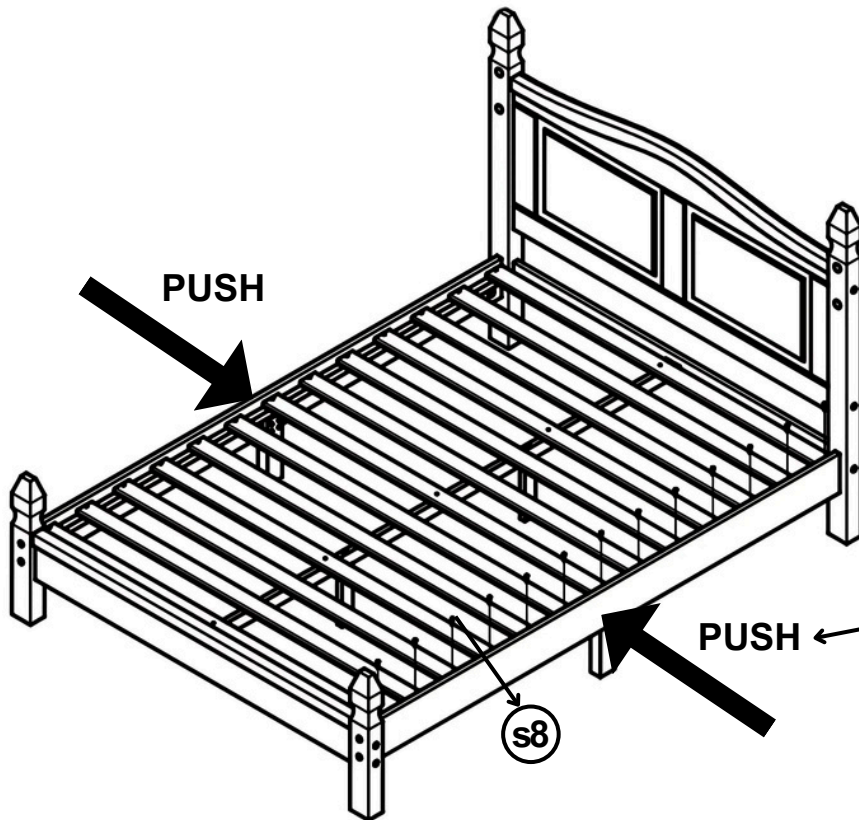

- Push the second side rail tightly against the slats. (s6)
- Use the spacer as shown to ensure correct spacing is maintained. (s7)
- Fix all the slats (Part 12 or 13) to the second side rail (Part 8). (s8)

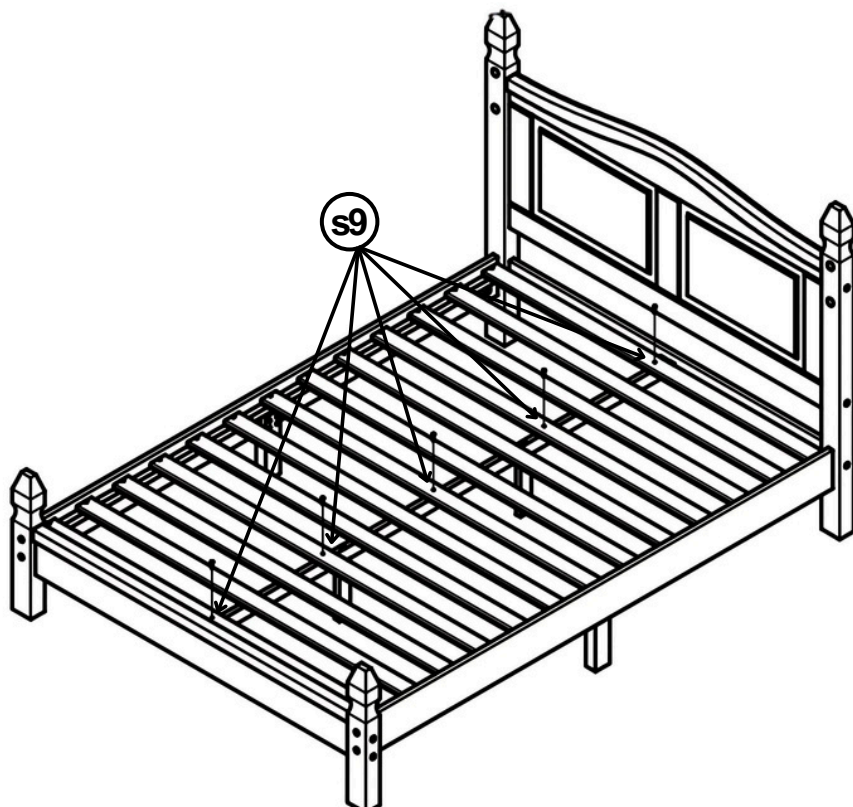
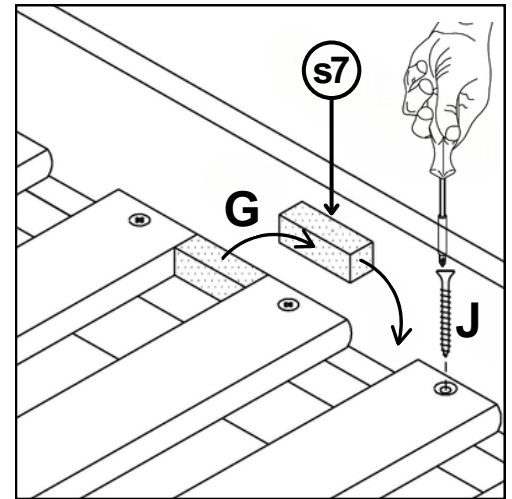

- If the central rail (Part 10) is misaligned, align it with the hole in the slat (Part 12). Once aligned, fix all the five central screws (Hardware J). (s9)