

Assembly Guide

Tip!

Do check for all the components and screws listed in this guide before putting things together.

Return Policy

Your satisfaction is our top priority. If our product fails to satisfy you, please let us know how we can make things right for you. Our trained customer care team can handle most concerns and assist you with any questions you may have. To be eligible for a full-refund return, the item must be in pristine condition, in the original packaging, with all of the shipped components intact and not yet assembled, and with the item's unique proof of purchase.

Trouble shooting:

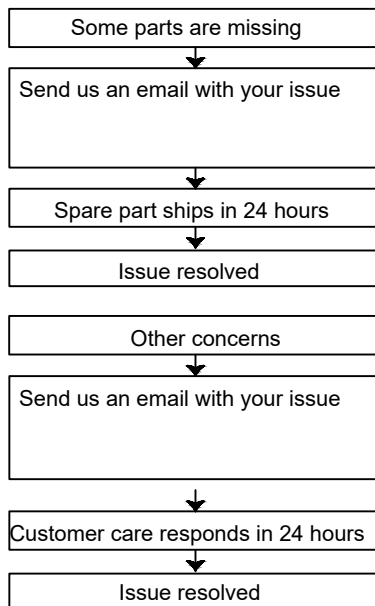

We run our own manufacturer, so rest assured about the quality consistency.

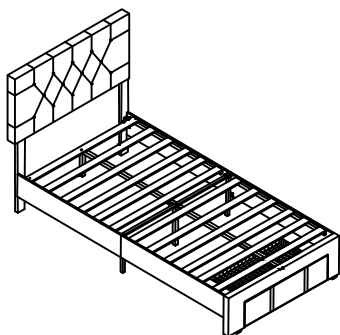

Item Description: Bed Frame

Montageanleitung

Tipp!

ÜBERPRÜFEN Sie alle in dieser Anleitung aufgeführten Komponenten und Schrauben, bevor Sie die Bauteile zusammenbauen.

Rückgaberrichtlinie

Ihre Zufriedenheit ist unsere oberste Priorität. Wenn Sie mit unserem Produkt nicht zufrieden sind, lassen Sie uns bitte wissen, wie wir die Angelegenheit für Sie in Ordnung bringen können. Unser geschultes Kundenbetreu kann die meisten Anliegen lösen und unter Sie bei allen Ihren Fragen. Um eine volle Rückerstattung zu erhalten, muss der Artikel in einwandfreiem Zustand sein und sich in der Originalverpackung mit allen gelieferten und noch nicht zusammengebaute Komponenten befinden. Zudem wird der eindeutige Kaufnachweis des Artikels.

Problemlösung:

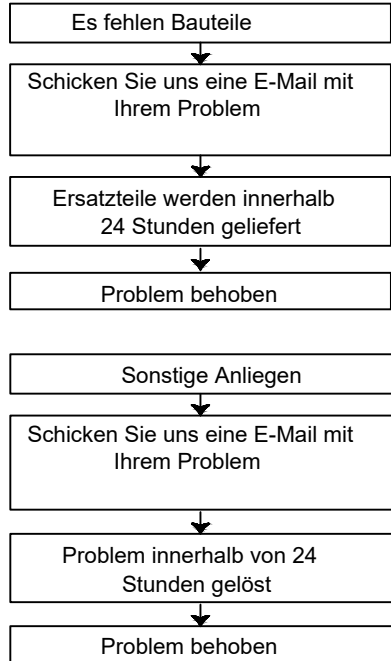

Wir stellen unsere Artikel selbst her, sodass Sie sich auf gleichbleibende Qualität verlassen können.

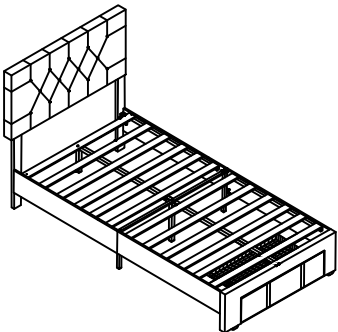

Item Description: Bettrahmen

Guide de montage

Attention !

VÉRIFIEZ la présence de l'ensemble des éléments et vis énumérés dans ce guide avant de procéder au montage.

Politique de retour

Votre satisfaction est notre priorité absolue. Si notre produit ne vous donne pas entière satisfaction, n'hésitez pas à nous faire savoir ce que nous pouvons faire pour améliorer la situation. Notre équipe d'assistance à la clientèle qualifiée est en mesure de résoudre la plupart de vos problèmes et de répondre à toutes vos questions. Pour pouvoir bénéficier d'un remboursement intégral, l'article doit être en parfait état, dans son emballage d'origine, avec tous les composants expédiés intacts et non encore assemblés, et avec la preuve d'achat unique de l'article.

Dépannage :

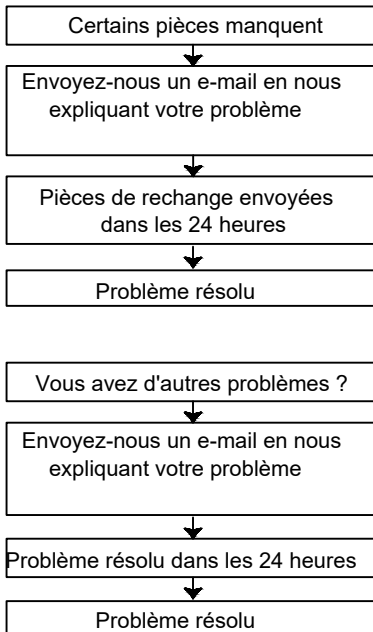

Nous assurons notre propre fabrication, donc soyez assuré de bénéficier d'une qualité constante.

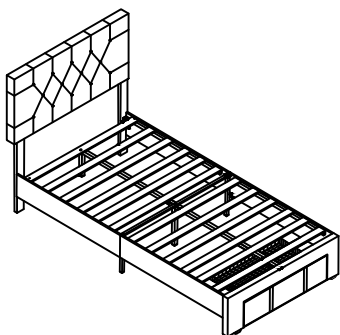

Item Description:

Cadre de lit

Guida all'assemblaggio

Mancia!

Controllare tutti i componenti e le viti elencati in questa guida prima di inserire le cose insieme.

Politica di ritorno

La vostra soddisfazione è la nostra massima priorità. Se il nostro il prodotto non ti soddisfa, faccelo sapere come possiamo sistemare le cose per te. Nostro un team di assistenza clienti qualificato può gestire la maggior parte preoccupazioni e assistervi per qualsiasi domanda tu forse hai. Essere eleggibile per un reso con rimborso completo, l'articolo deve essere presente ottime condizioni, nella confezione originale, con tutti i componenti spediti intatti e non ancora assemblato e con l'oggetto unico prova d'acquisto.

Risoluzione dei problemi:

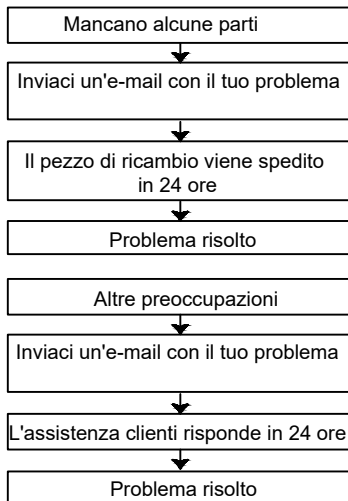

Gestiamo il nostro produttore, quindi riposati assicurato circa la consistenza di qualità.

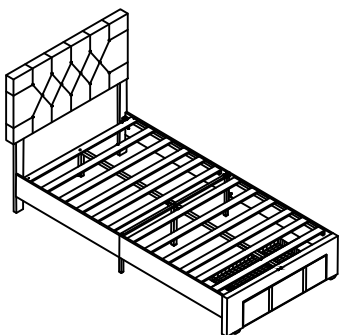

Descrizione dell'articolo: Telaio del letto

Guía de montaje

Consejo !

Verifique todos los componentes y tornillos. Enumerados en esta guía antes de poner las cosas juntos.

Política de devoluciones

Su satisfacción es nuestra máxima prioridad. Si nuestro el producto no le satisface, háganoslo saber. CÓMO podemos hacer las cosas bien para usted. Nuestro equipo de atención al cliente capacitado puede manejar la mayoría inquietudes y ayudarle con cualquier pregunta es posible que tengas. Ser elegible para una devolución con reembolso completo, el artículo debe estar en impecable estado, en el embalaje original, con todos los componentes enviados intactos y aún no ensamblado y con la característica única del artículo. Comprobante de compra.

Solución de problemas:

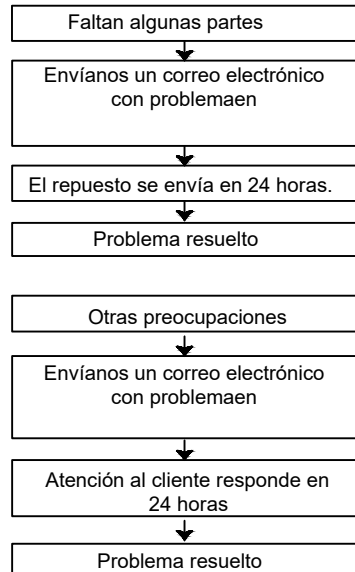

Dirigimos nuestro propio fabricante, así que descansa. Asegurado sobre la consistencia de la calidad

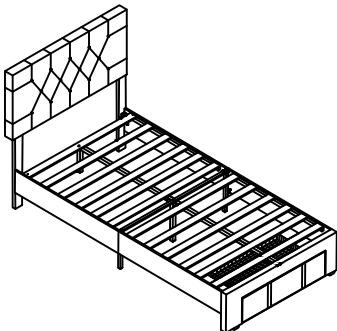

Descripción del artículo: Marco de la cama

CAUTION!

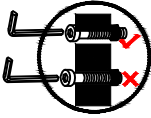

ACHTUNG!

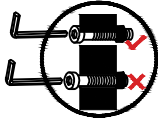

ATTENTION !

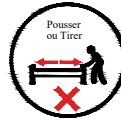
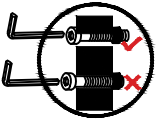

CAUTELA !

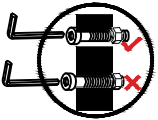



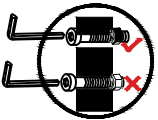

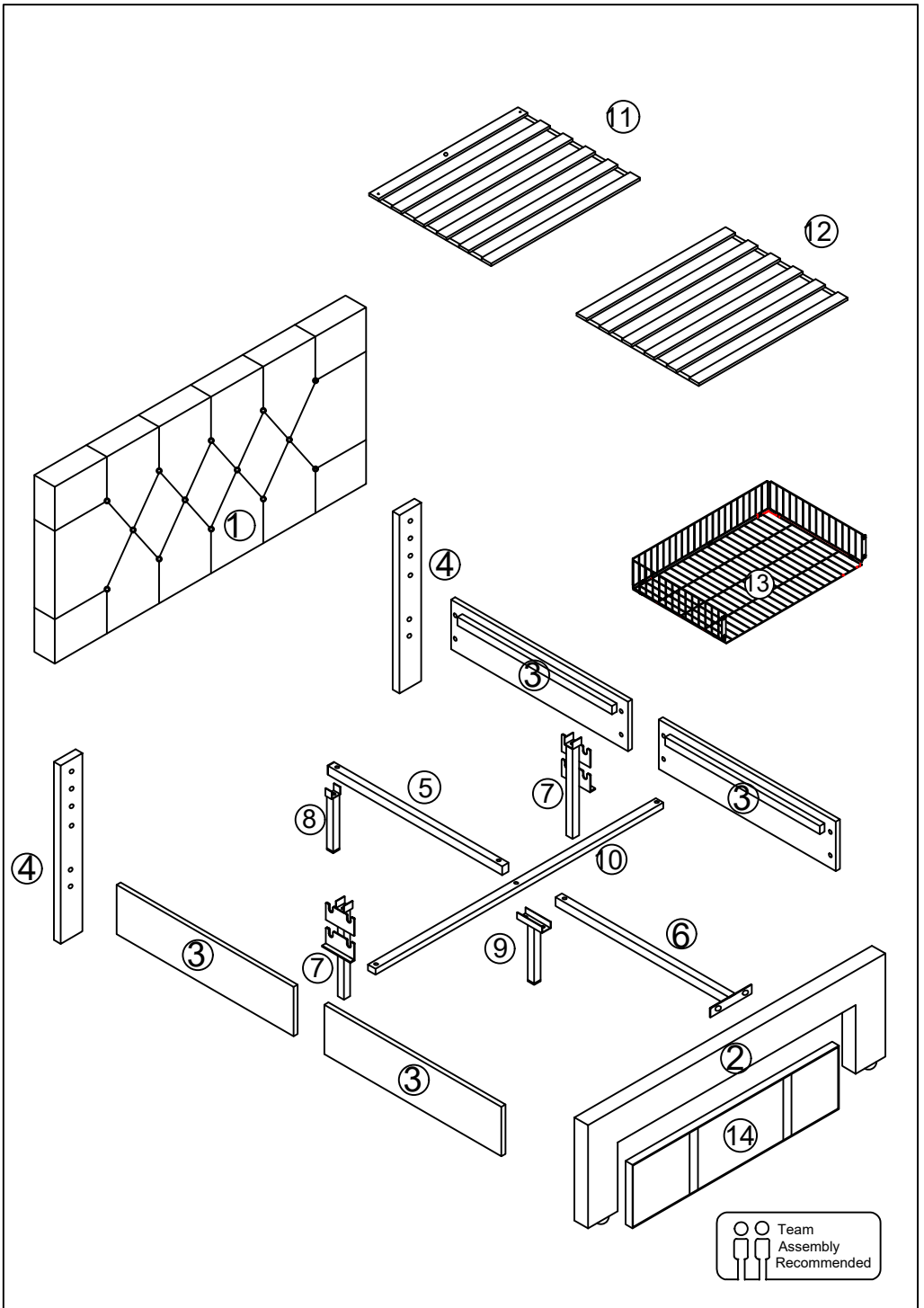



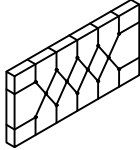
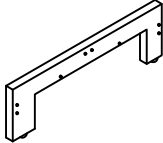
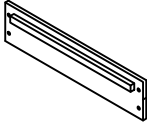
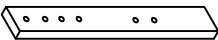
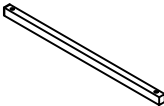
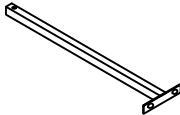

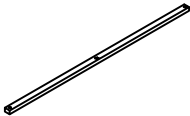
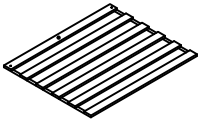
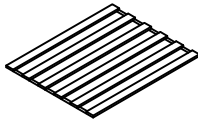
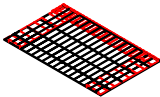
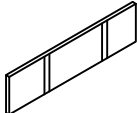
PRECAUCIÓN !







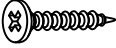



Components / Bauteile / Compositants / Componenti / Componentes

<p>①</p>		<p>1pc</p>	<p>②</p>		<p>1pc</p>
<p>③</p>		<p>4pcs</p>	<p>④</p>		<p>2pcs</p>
<p>⑤</p>		<p>1pc</p>	<p>⑥</p>		<p>1pc</p>
<p>⑦</p>		<p>2pcs</p>	<p>⑧</p>		<p>1pc</p>
<p>⑨</p>		<p>1pc</p>	<p>⑩</p>		<p>1pc</p>
<p>⑪</p>		<p>1pc</p>	<p>⑫</p>		<p>1pc</p>
<p>⑬</p>		<p>1pc</p>	<p>⑭</p>		<p>1pc</p>

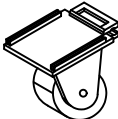
<p>(A)</p>	 Bolt M6 x 15	<p>5</p>	<p>(B)</p>	 Bolt M8 x 16	<p>16+1</p>
<p>(C)</p>	 Bolt M8 x 25	<p>14+1</p>	<p>(D)</p>	 Bolt M8 x 45	<p>7+1</p>
<p>(E)</p>	 Spacer	<p>4</p>	<p>(F)</p>	 SCREW M4*25	<p>2</p>
<p>(G)</p>	 Allen Key M5	<p>1</p>	<p>(H)</p>	 Allen Key M4	<p>1</p>

<p>(I)</p>	 Angle iron	<p>2</p>	<p>(J)</p>	 Angle iron	<p>2</p>
<p>(K)</p>	 Hook	<p>1</p>	<p>(L)</p>	 Plastic Buckles	<p>2</p>
<p>(M)</p>	 Wheel	<p>5</p>	<p>(O)</p>	 Plastic Buckles	<p>2</p>

Step 1



D*4



E*4



G*1

- Each pair of holes corresponds to a mattress thickness as shown below.
- ★ Chaque paire de trous correspond à une épaisseur de matelas, comme indiqué ci-dessous.
- ▲ Jedes Paar Löcher entspricht einer Matratzenstärke, wie unten gezeigt.
- Ogni coppia di fori corrisponde ad uno spessore del materasso come mostrato di seguito.
- ✿ Cada par de agujeros corresponde al grosor del colchón, como se muestra a continuación.

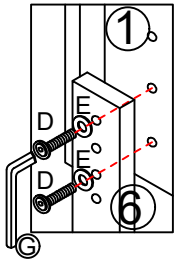
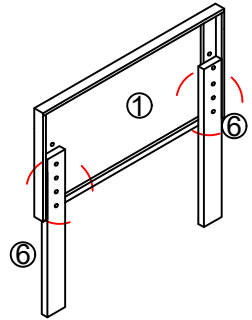

- Use these holes to fit a 12 inch thick mattress (45.6 inch tall overall)
- ★ Utilisez ces trous pour s'adapter à un matelas de 12 Centimètres d'épaisseur (45.6 Centimètres de hauteur totale)
- ▲ Jedes Paar Löcher entspricht einer Matratzendicke. Um eine 12-Zentimeter-Matratze anzupassen (Insgesamt 45.6 Zentimeter)
- Utilizzare questi fori per adattarsi a un materasso spesso 12 pollici (alto complessivamente 45.6 pollici)
- ✿ Utilice estos agujeros para adaptarse a un colchón de 12 pulgadas de grosor (45.6 pulgadas de alto en total)

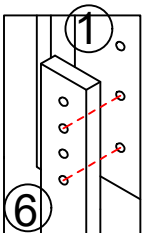

- Use these holes to fit a 10 inch thick mattress (43.6 inch tall overall)
- ★ Utilisez ces trous pour s'adapter à un matelas de 10 Centimètres d'épaisseur (43.6 Centimètres de hauteur totale)
- ▲ Jedes Paar Löcher entspricht einer Matratzendicke. Um eine 10-Zentimeter-Matratze anzupassen (Insgesamt 43.6 Zentimeter)
- Utilizzare questi fori per adattarsi a un materasso spesso 10 pollici (alto complessivamente 43.6 pollici)
- ✿ Utilice estos agujeros para adaptarse a un colchón de 10 pulgadas de grosor (43.6 pulgadas de alto en total)

Step 1.1

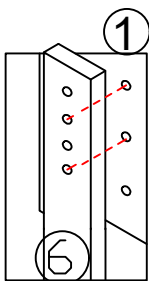



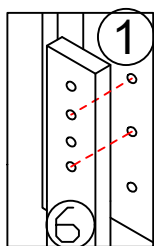

- Use these holes to fit a 8 inch thick mattress (41.6inch tall overall)
- ★ Utilisez ces trous pour s'adapter à un matelas de 8 Centimètres d'épaisseur (41.6 Centimètres de hauteur totale)
- ▲ Jedes Paar Löcher entspricht einer Matratzendicke. Um eine 8-Zentimeter-Matratze anzupassen (Insgesamt 41.6 Zentimeter)
- Utilizzare questi fori per adattarsi a un materasso spesso 8 pollici (alto complessivamente 41.6 pollici)
- ✿ Utilice estos agujeros para adaptarse a un colchón de 8 pulgadas de grosor (41.6 pulgadas de alto en total)



- Use these holes to fit a 6 inch thick mattress (39.6 inch tall overall)
- ★ Utilisez ces trous pour s'adapter à un matelas de 6 Centimètres d'épaisseur (39.6 Centimètres de hauteur totale)
- ▲ Jedes Paar Löcher entspricht einer Matratzendicke. Um eine 6-Zentimeter-Matratze anzupassen (Insgesamt 39.6 Zentimeter)
- Utilizzare questi fori per adattarsi a un materasso spesso 6 pollici (alto complessivamente 39.6 pollici)
- ✿ Utilice estos agujeros para adaptarse a un colchón de 6 pulgadas de grosor (39.6 pulgadas de alto en total)

Step 2

	B*8		J*2
	I*2		G*1

Tips:
Must Keep the Brackets
Lay Toward the Ground

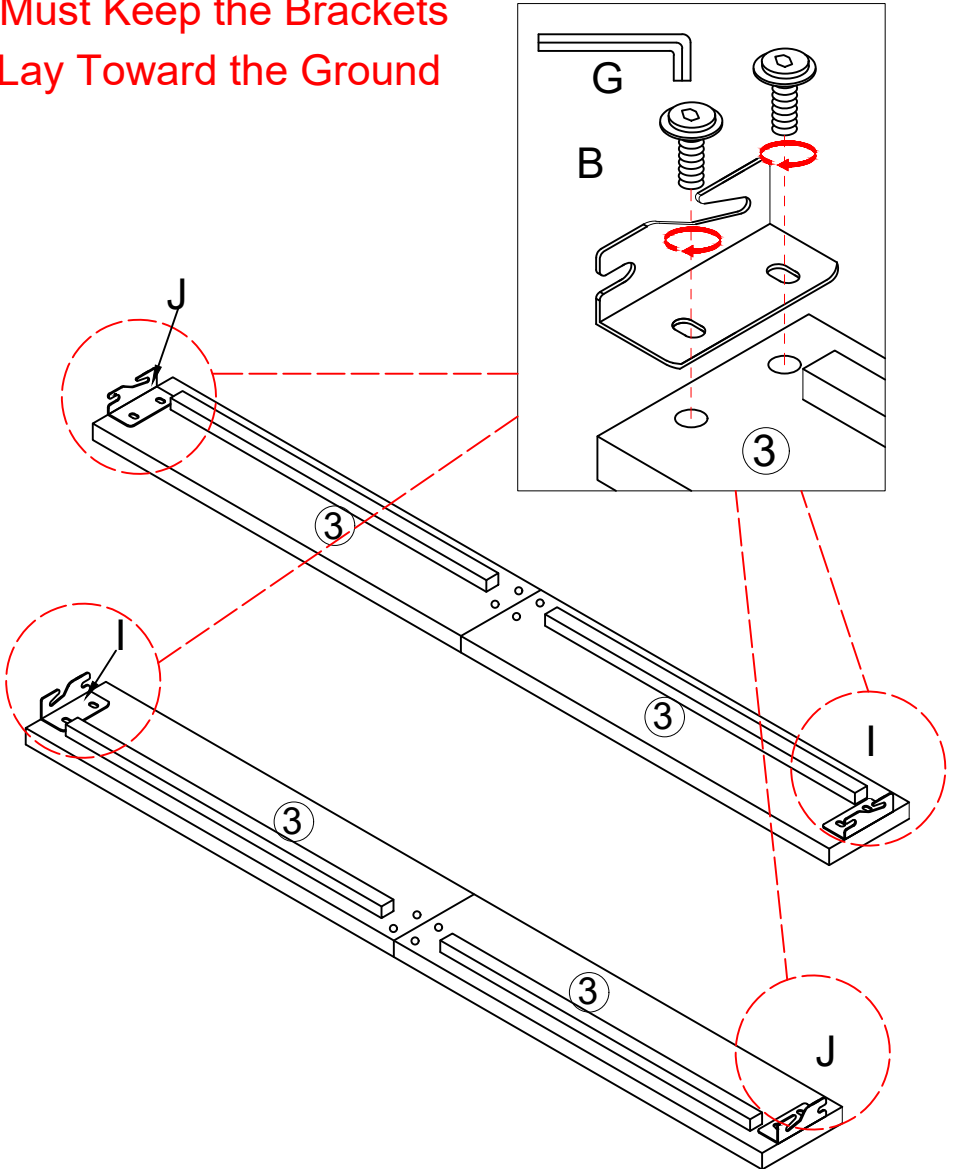

Step 3



B*8

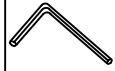

G*1

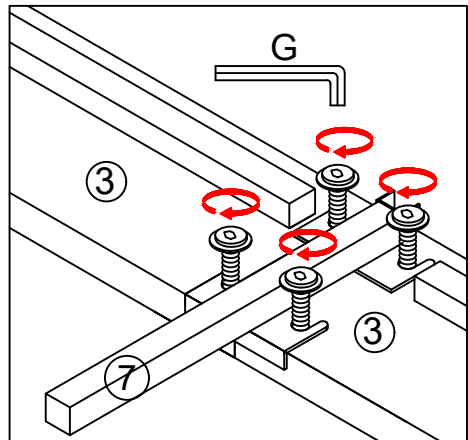
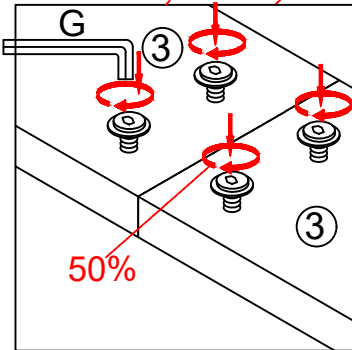
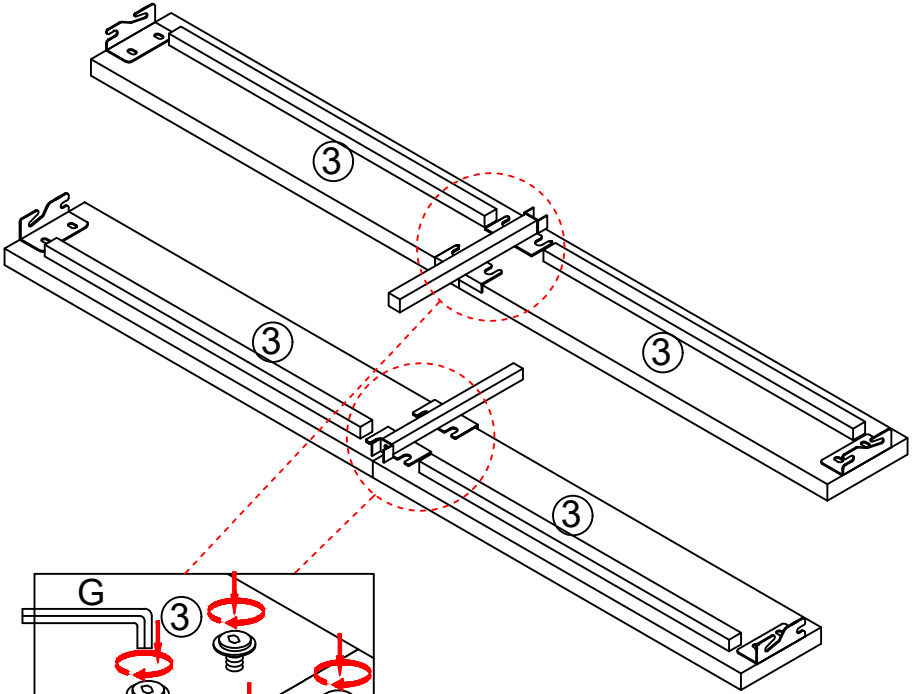

Step 4

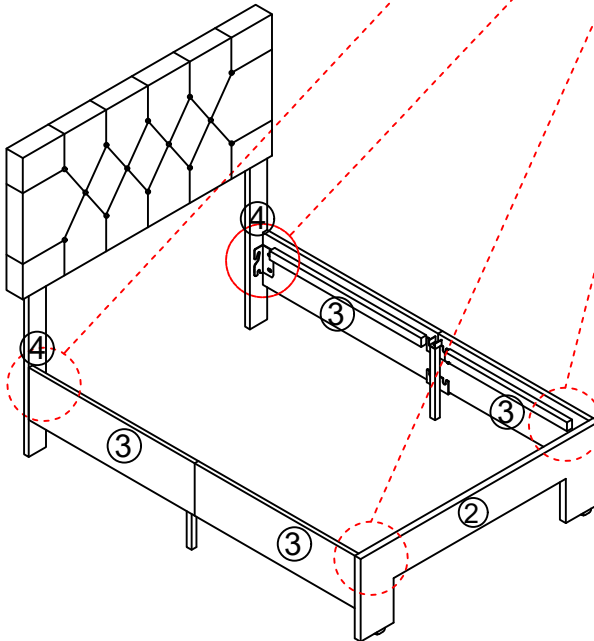
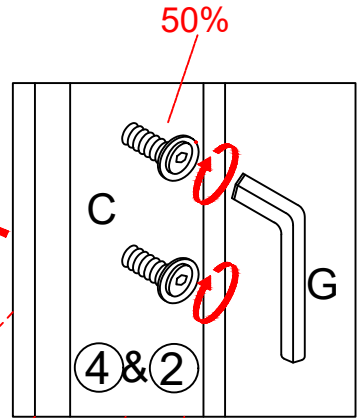
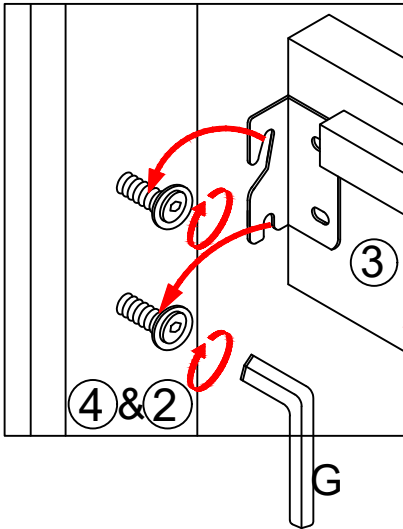
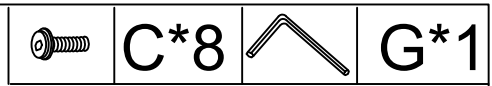

Step 5



C*2

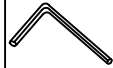

G*1

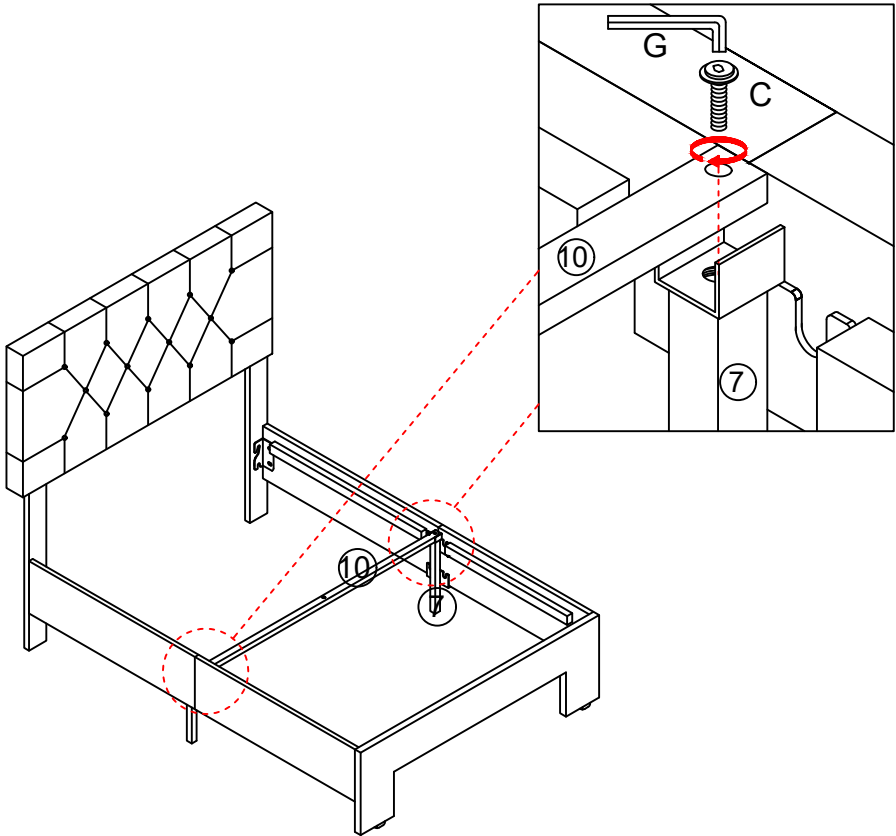

Step 6



C*2



D*2



G*1

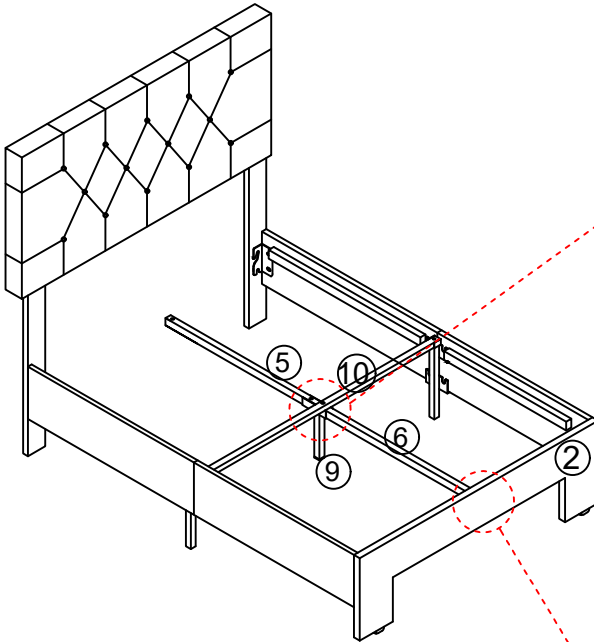

6-2

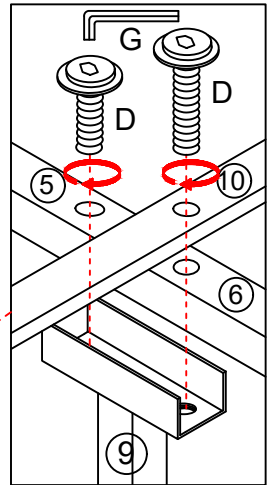

6-1

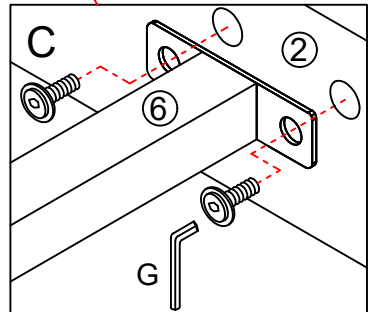

Tighten the original screw

Step 7



C*2



O*2

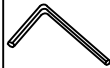

G*1

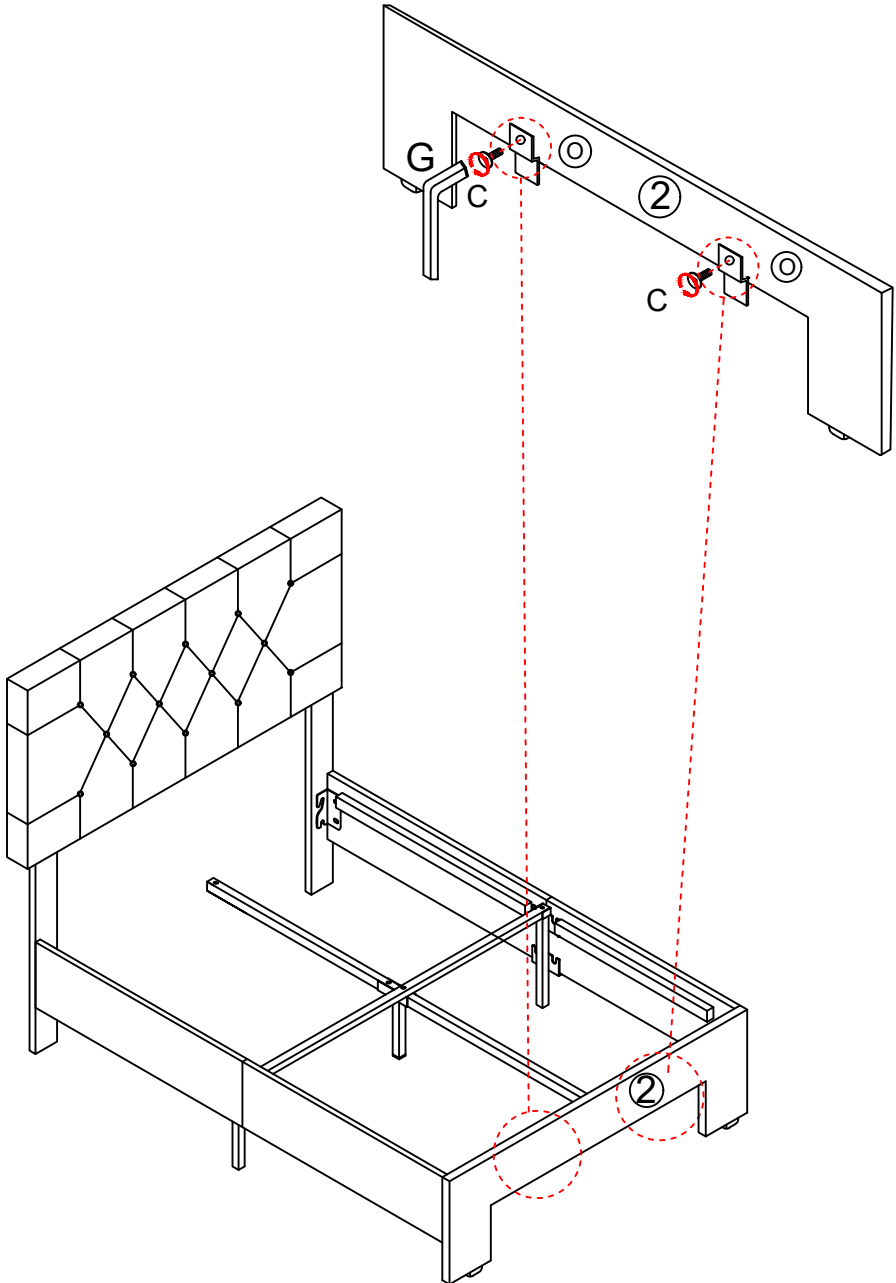

Step 8



D*1



F*2

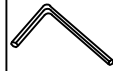

G*1

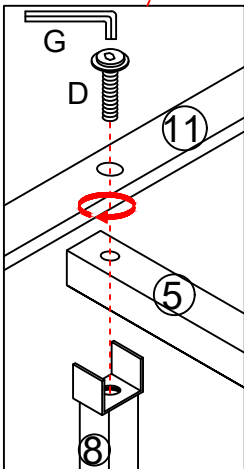
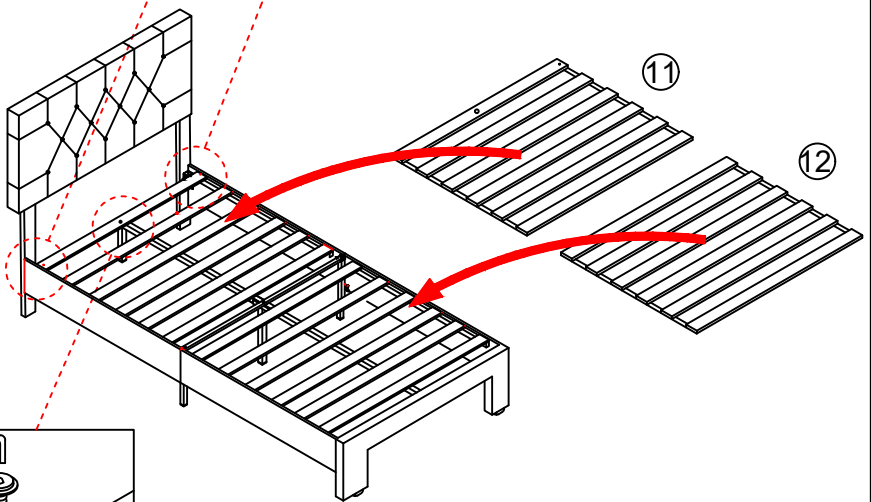
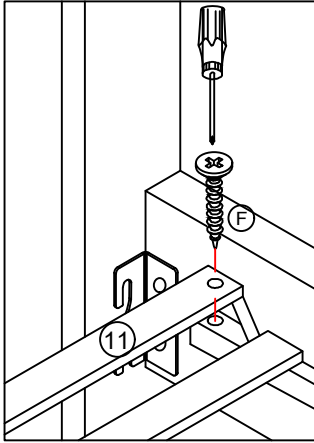

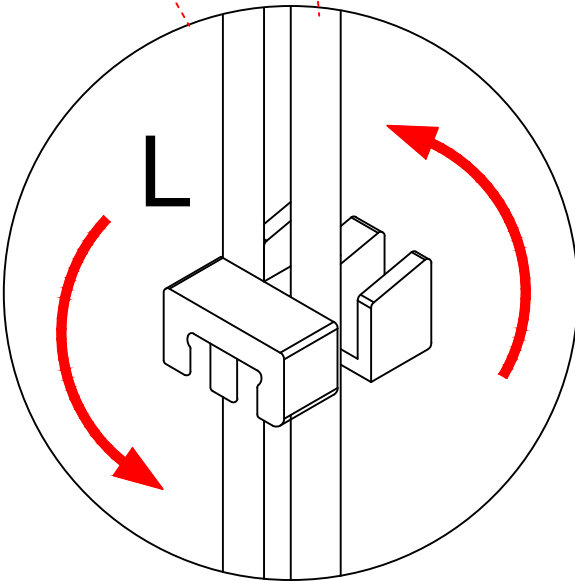
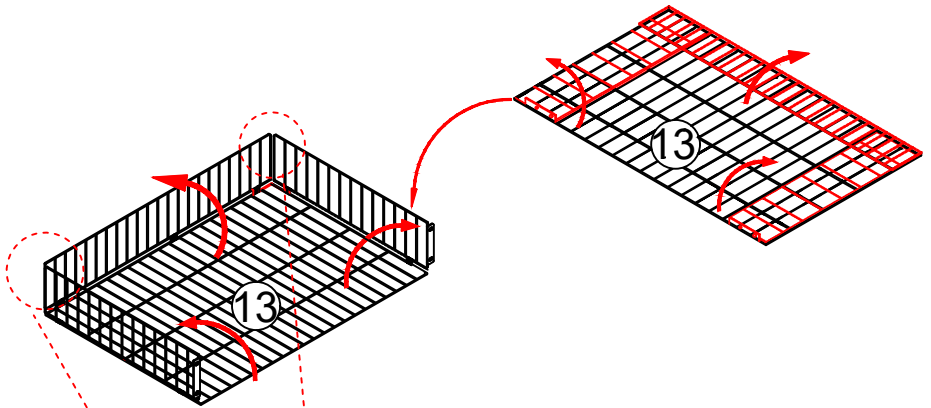

Step 10



A*5



K*1

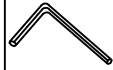

H*1

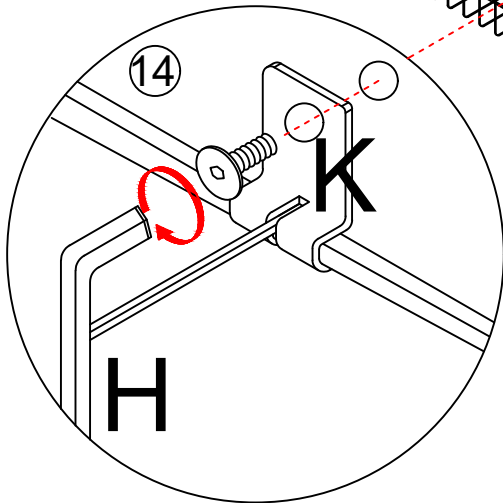
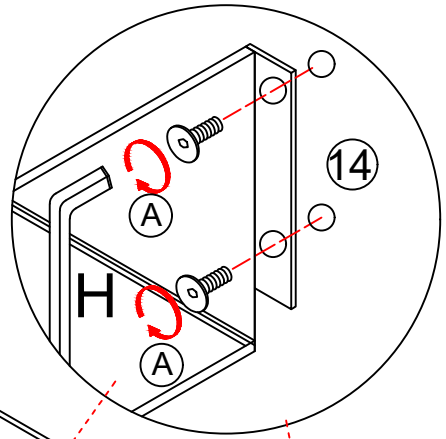
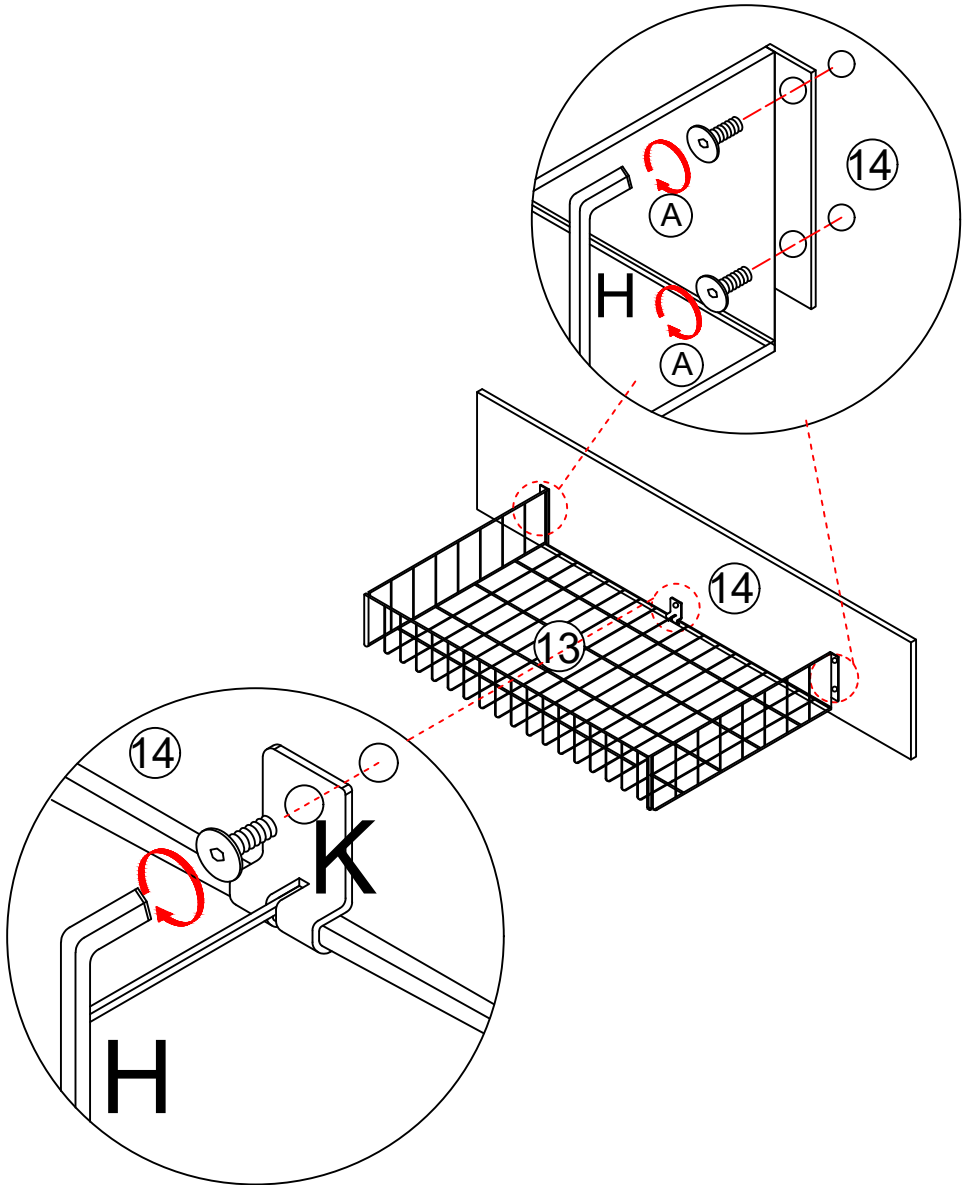

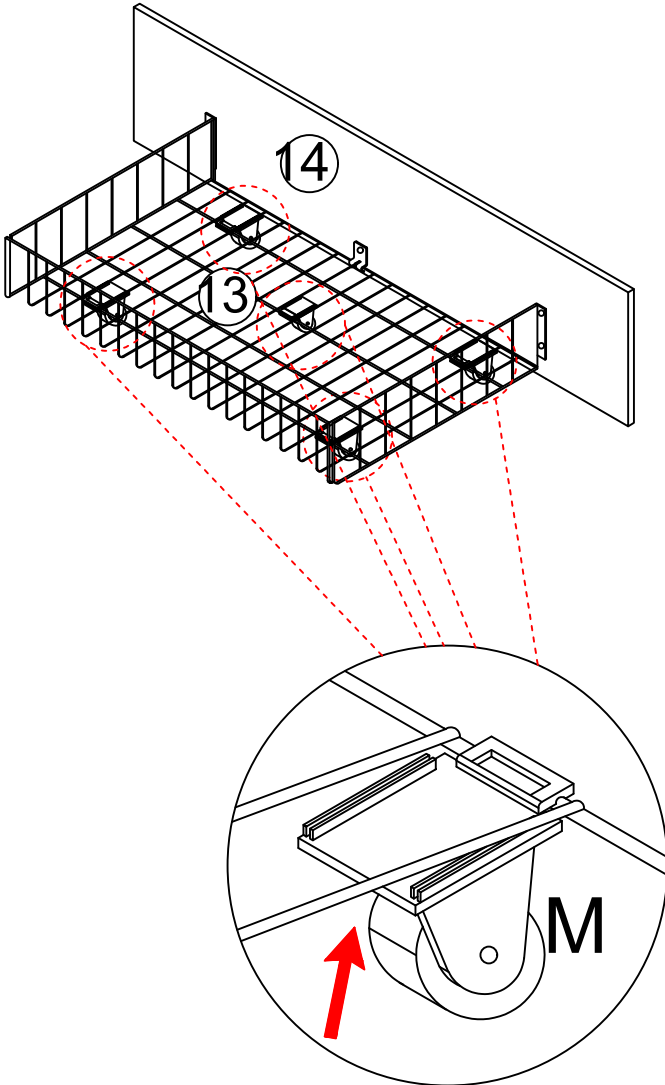

Step 12

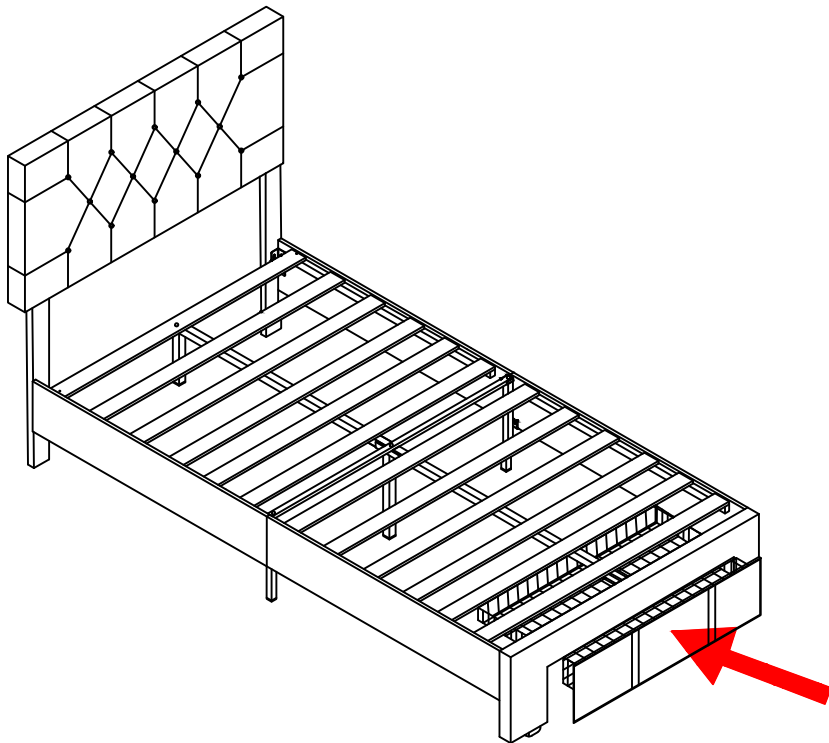

Step 13

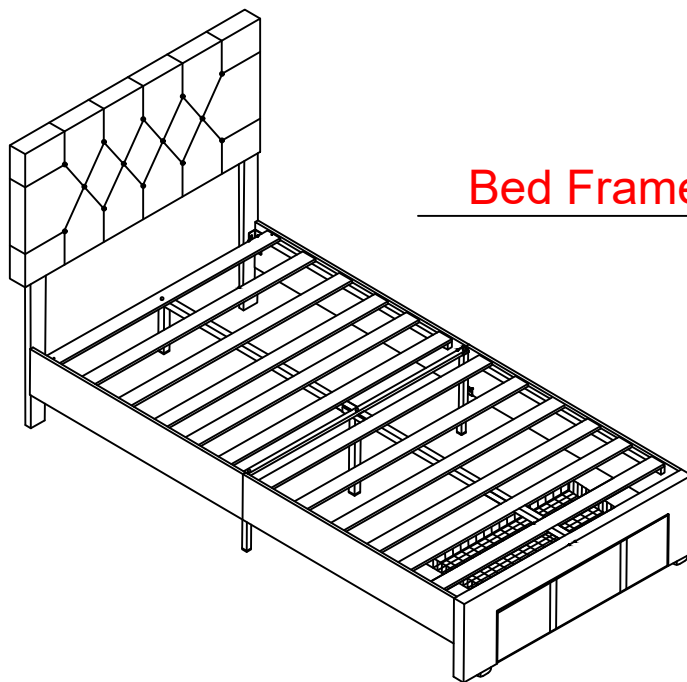

Bed Frame