

**STORAGE NOOK GREY STRIPED FABRIC  
COIN PETIT-DÉJEUNER TISSU RAYURES GRIS  
BANCO ESQUINERO TAPIZADO RAYADO GRIS**

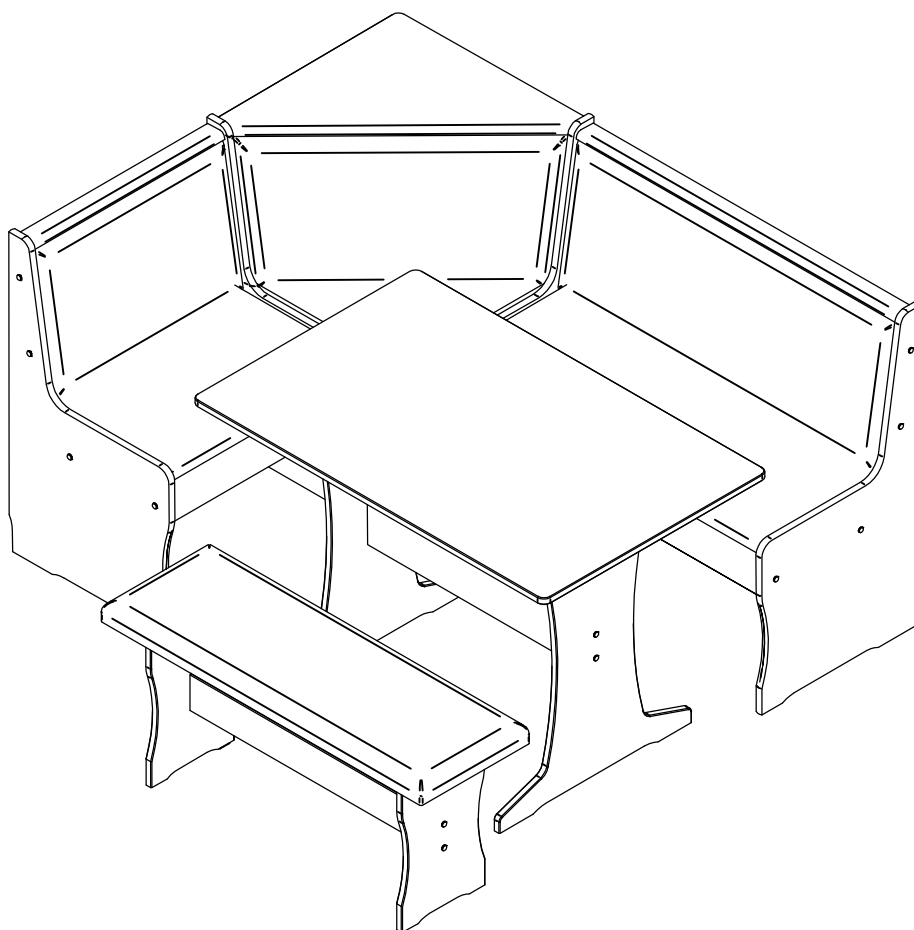

## SELECT THE LAYOUT OF THE BENCH

THIS ITEM IS REVERSIBLE AND CAN BE INSTALLED EITHER WITH THE LARGE BENCH ON YOUR LEFT HAND SIDE (LEFT SIDE INSTALLATION) OR WITH THE LARGE BENCH ON YOUR RIGHT HAND SIDE (RIGHT SIDE INSTALLATION).

**THIS INSTRUCTION IS MADE FOR RIGHT HAND INSTALLATION.**

IF YOU SELECT THE LEFT HAND INSTALLATION, THEN YOU HAVE TO SWITCH ALL THE PARTS LOCATED ON THE RIGHT PART (14,15,16,17 AND 19) TO THE LEFT PART AND THE PARTS LOCATED ON THE LEFT PART (04, 05, 06, 07 AND 08) TO THE RIGHT PART.

**ATTENTION:** OUTSIDE LEGS #1 AND #03 PLUS CENTRAL PIECES (02, 09, 10, 11, 12 AND 13) REMAIN UNCHANGED.

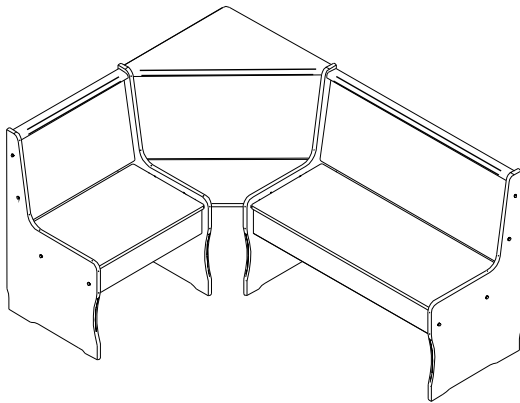

**RIGHT SIDE INSTALLATION**

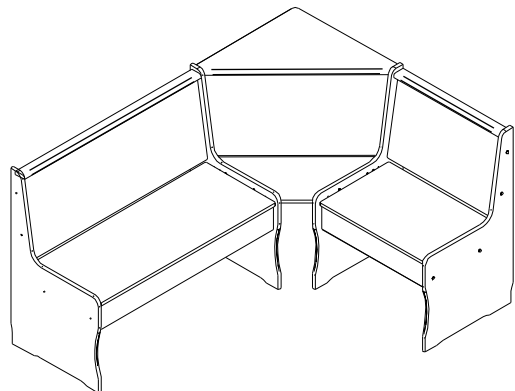

**LEFT SIDE INSTALLATION**

**NOTE:** BEFORE STARTING THE ASSEMBLY PROCESS, ALL PARTS SHOULD BE SEPARATED ACCORDING TO THE ITEM THEY BELONG TO FOR BETTER IDENTIFICATION OF ALL PARTS, PLEASE USE THE PART IDENTIFICATION LIST ON PAGE 4 FOR THE CORNER BENCH, THE PART IDENTIFICATION LIST ON PAGE 15 FOR THE TABLE AND THE PART IDENTIFICATION LIST ON PAGE 20 FOR THE SIMPLE BENCH.

### NOTICE

This Product consists of 2 cartons total:

Carton A: #01 #02 #03 #04 #05 #06 #07 #08  
#09 #10 #11 #12 #13 #14 #15 #16  
#17 #18 #19 + Hardware

Carton B: #20, #21, #22, #23, #24, #25, #26, #27, #28  
+ Hardware

Please verify you have both 2 cartons

### AVERTISSEMENT

Ce produit est emballé en deux boîtes:

Boîte A: #01 #02 #03 #04 #05 #06 #07 #08  
#09 #10 #11 #12 #13 #14 #15 #16  
#17 #18 #19 + Ferrures

Boîte B: #20, #21, #22, #23, #24, #25, #26, #27, #28  
+ Ferrures

Prière de vérifier que vous avez les deux boîtes.

### ADVERTENCIA

Este producto está embalado en dos cajas:

Caja A: Nos. #01 #02 #03 #04 #05 #06 #07 #08  
#09 #10 #11 #12 #13 #14 #15 #16  
#17 #18 #19 + Herraje

Caja B: Nos. #20, #21, #22, #23, #24, #25, #26, #27, #28  
+ Herraje

Sírvase verificar que tiene las dos cajas.

## Part list / Liste des pièces / Lista de piezas

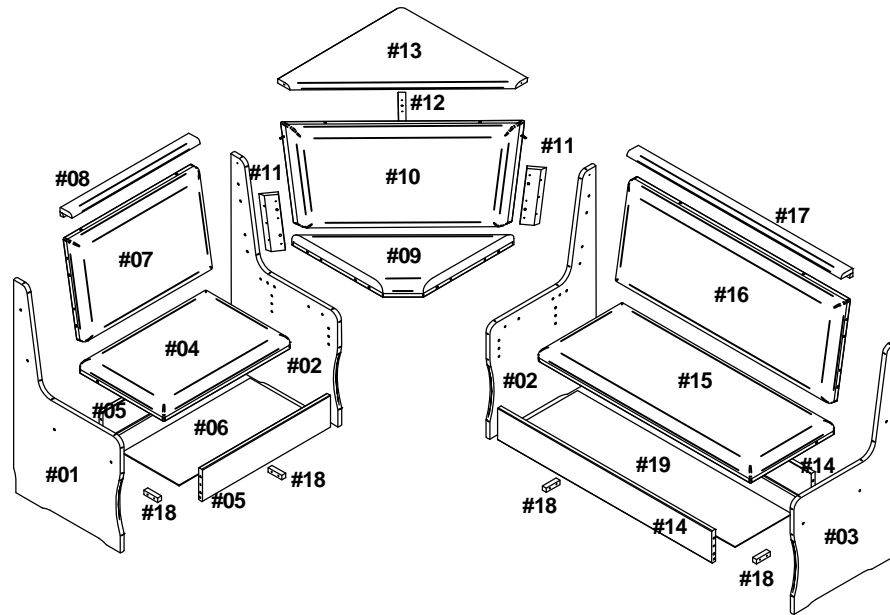

| Description   | Qty. |
|---|------|
| Left outside leg / Latéral extérieure gauche / Lateral exterior izquierda                                 | 01   |
| Middle leg / Latéral Moyenne / Lateral media  | 02   |
| Right outside leg / Latéral extérieure droite / Lateral exterior derecha                                  | 01   |
| Single bench seat / Siège de banc unique / Asiento banco simple   | 01   |
| Single bench rail / Rail de banc unique / Travessaño banco simple   | 02   |
| Single bench storage bottom / Bas de stockage de banc unique / Inferior de almacenamiento banco simple    | 01   |
| Single bench back rest / Dossier de banc unique / Respaldo banco simple                                   | 01   |
| Top rail for single backrest / Rail supérieur pour dossier unique / Detalle superior para respaldo simple | 01   |
| Corner seat / Siège de coin / Asiento esquinero   | 01   |
| Center back panel / Panneau arrière central / Panel trasero central                                       | 01   |
| Rail center back panel / Rail panneau arrière central / Riel panel trasero central                        | 02   |
| Top panel corner support / Support de coin du panneau supérieur / soporte de esquina del panel superior   | 01   |
| Corner top panel / Panneau supérieur de coin / Panel superior de esquinero                                | 01   |
| Double bench rail / Rail de banc double / Travessaño banco doble  | 02   |
| Double bench seat / Siège de banc double / Asiento banco doble  | 01   |
| Double bench backrest / Dossier de banc double / Respaldo banco doble                                     | 01   |
| Top rail for double back rest / Rail supérieur pour dossier double / Detalle superior para respaldo doble | 01   |
| Rail / Rail / Riel  | 04   |
| Double bench storage bottom / Bas de stockage de banc double / Inferior de almacenamiento banco doble     | 01   |
| Nook hardware pack / Ferrures / Paquete de herraje  | 01   |

HARDWARE PACKAGE - CORNER BENCH / PAQUET DE FERRURES - BANC D'ANGLE / PAQUETE DE HERRAGE - BANCO ESQUINERO

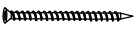
|   |   |   |    |
|---|---|---|----|
| A | Wood dowel (8x30) / Goujons de bois / Tarugo de madeira |  | 36 |
| B | Bolt (7x50mm) / Boulon / Tornillo                       |  | 20 |
| C | Screw (3,5x35mm) / Vis / Tornillo                       |  | 04 |
| D | Screw (3,5x30mm) / Vis / Tornillo                       |  | 28 |
| E | Screw cap / Bouchon à vis / Tapón de tornillo           |  | 08 |
| F | Pin / Goupille / Pino                                   |  | 04 |
| G | Screw (4,0X50mm) / Vis / Tornillo                       |  | 02 |
| H | Allen wrench / Clé allen / Llave allen                  |  | 01 |
| I | Wood dowel (8x20) / Goujons de bois / Tarugo de madeira |  | 04 |

**Tools required / Outils requis / Herramientas requeridas**

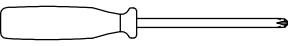
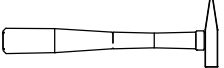
|   |  |   |
|---|--|---|
| Philips screwdriver / Tournevis Philips / Destornillador estándar |  | Not supplied / Non fourni / No incluido |
| Hammer / Marteau / Martillo                                       |  | Not supplied / Non fourni / No incluido |

**IMPORTANT:**

1. Do not tighten bolts completely until all bolts are completely lined up and inserted into holes / nuts.
2. Do not over tighten screws and bolts to avoid stripping.
3. Please use hand tools to assemble this product. Do not use power tools.

**IMPORTANT:**

1. Ne serrez pas complètement les boulons jusqu'à ce que tous les boulons soient complètement alignés et insérés dans les trous / écrous.
2. Ne pas trop serrer les vis et les boulons pour éviter d'endommager les filets.
3. Utilisez des outils à main pour assembler ce produit. N' utilisez pas d'outils électriques.

**IMPORTANTE:**

1. No apriete completamente los pernos hasta que todos los tornillos estén alineados completamente y se inserten en los agujeros / tuercas.
2. No apriete demasiado los tornillos y los pernos para evitar dañar los filetes.
3. Utilice herramientas de mano para montar este producto. No utilice herramientas eléctricas.

**USE / MANTINENCE**

1. Indoor use only.
2. Wipe clean with damp cloth.

**UTILISER / MAINTENANCE**

1. Doit être utilisé à l'intérieur seulement.
2. Nettoyez avec un linge humide.

**USO / MANTENIMIENTO**

1. Solamente usar en espacios internos.
2. Limpiar con un trapo húmedo.

1.

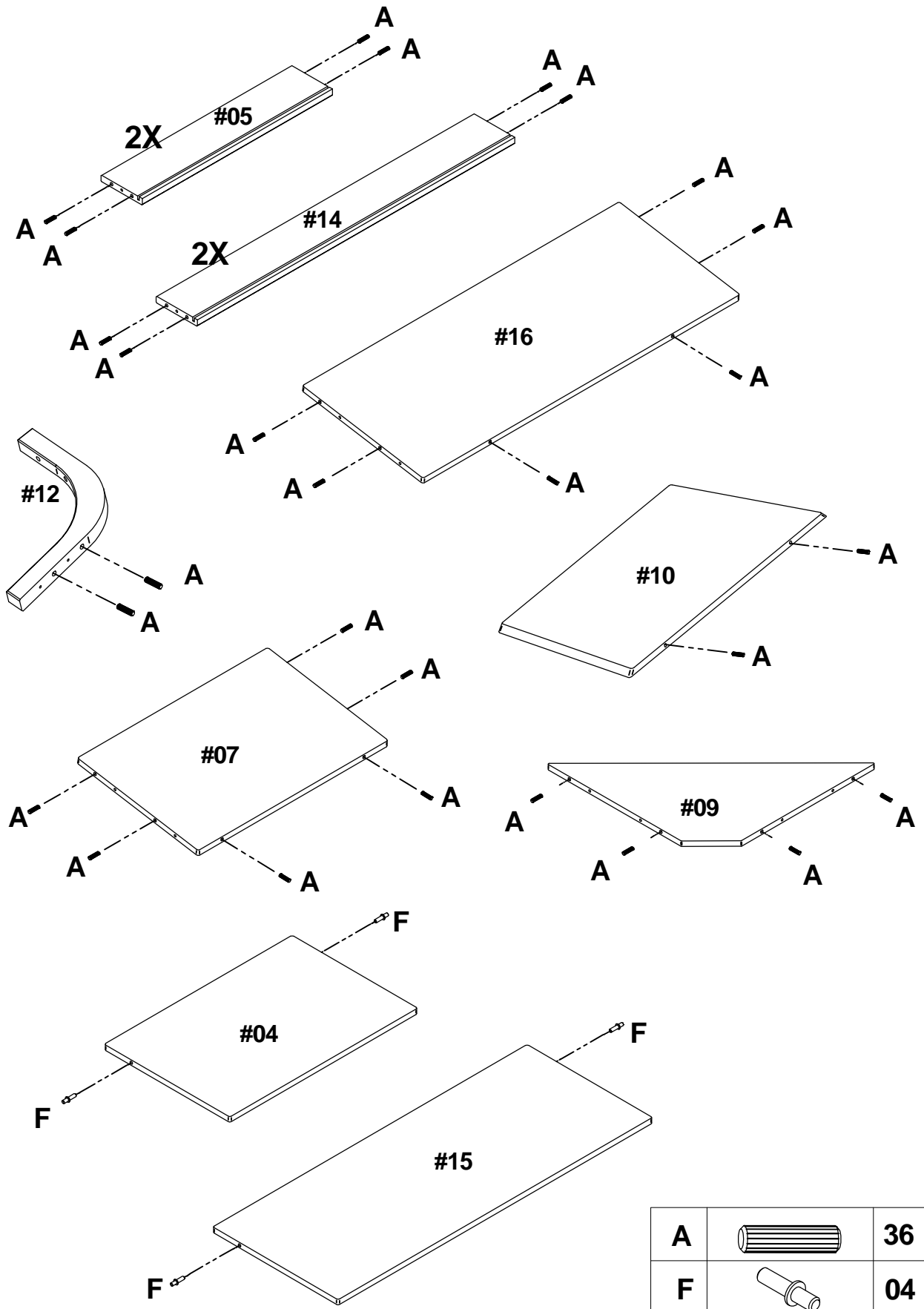

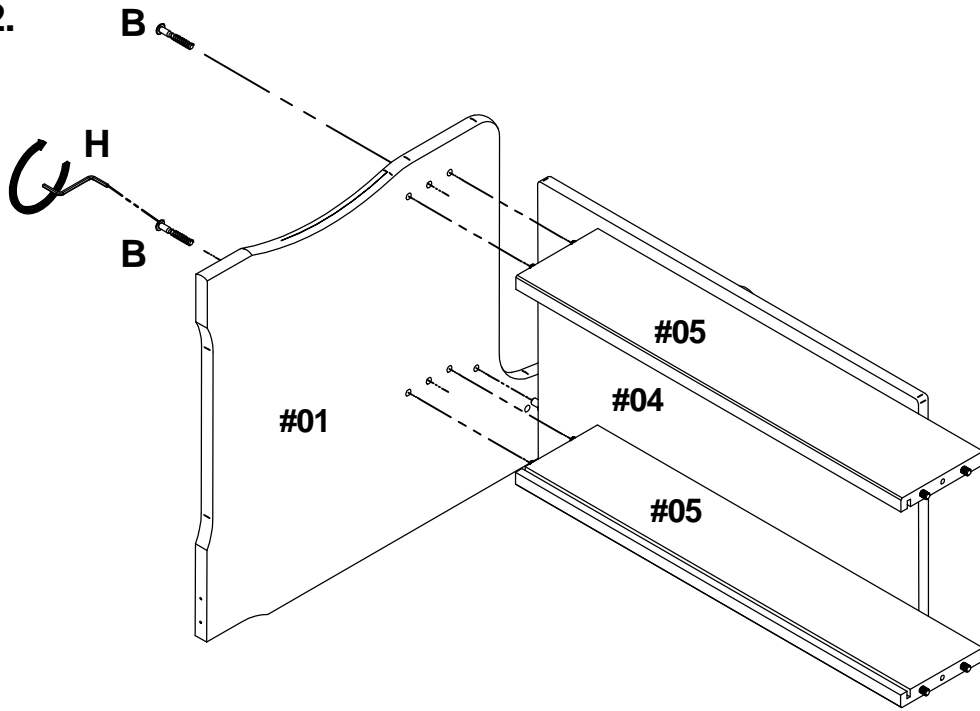

2.

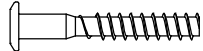

|   |   |    |
|---|---|----|
| H |  | 01 |
| B |  | 02 |

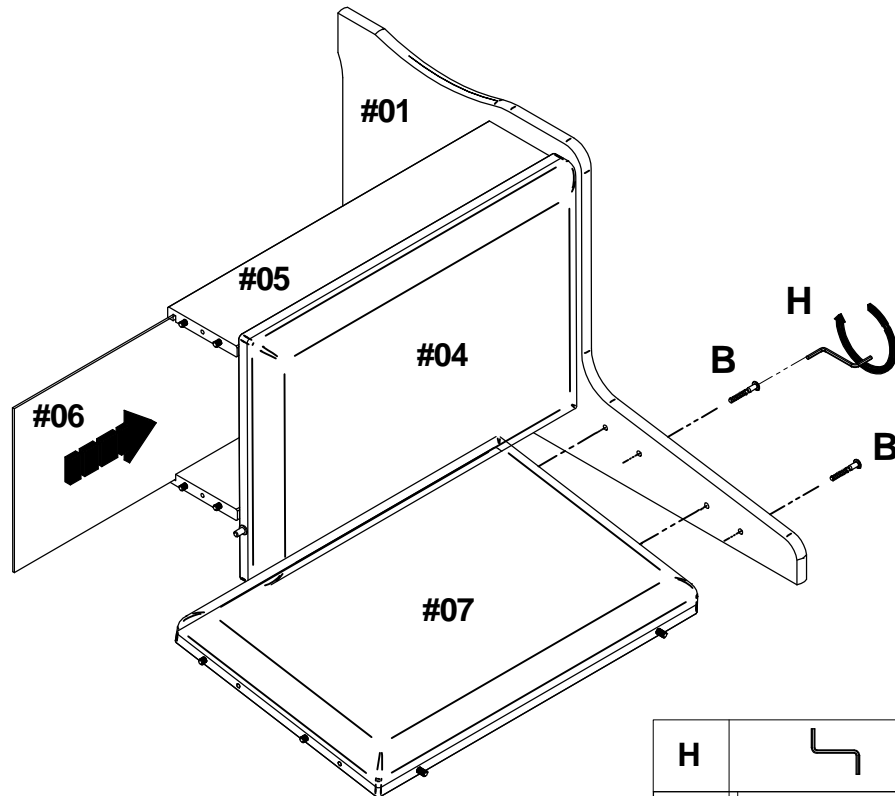
3.

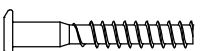

|   |   |    |
|---|---|----|
| H |  | 01 |
| B |  | 02 |

4.

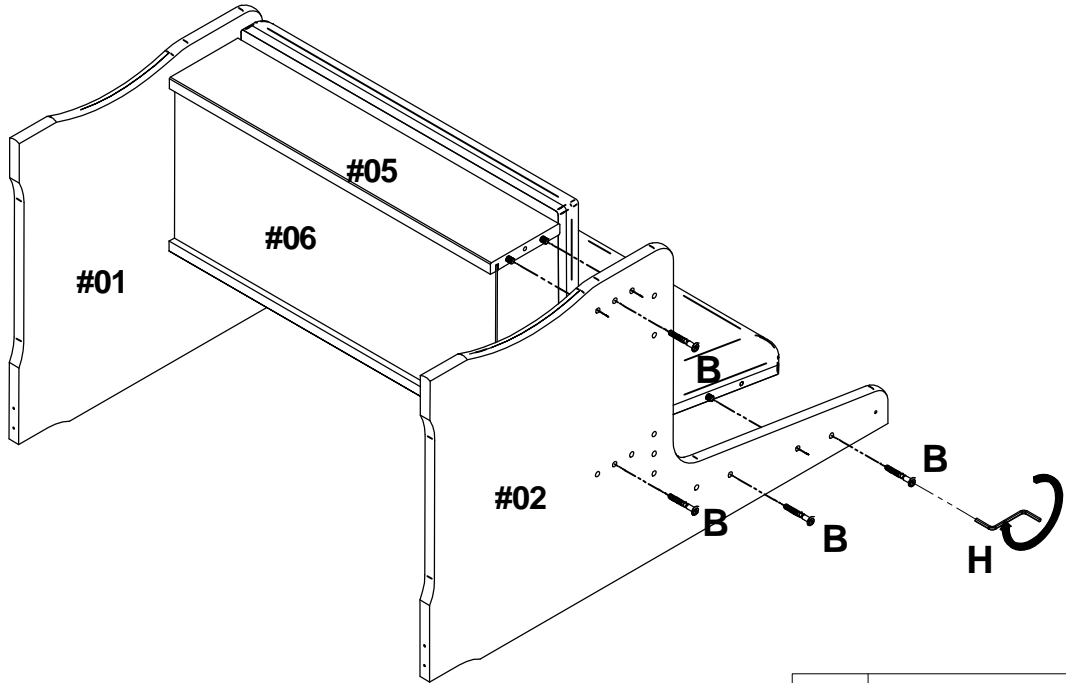

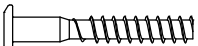
|   |   |    |
|---|---|----|
| H |  | 01 |
| B |  | 04 |

5.

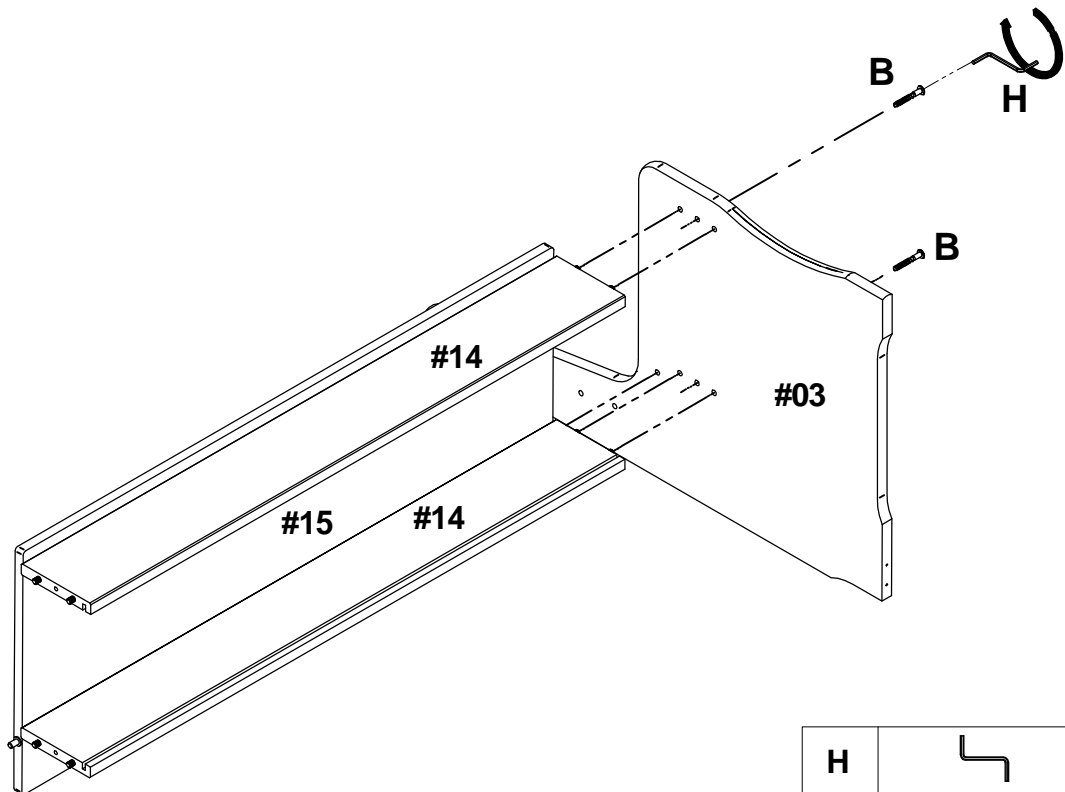

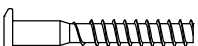
|   |   |    |
|---|---|----|
| H |  | 01 |
| B |  | 02 |

6.

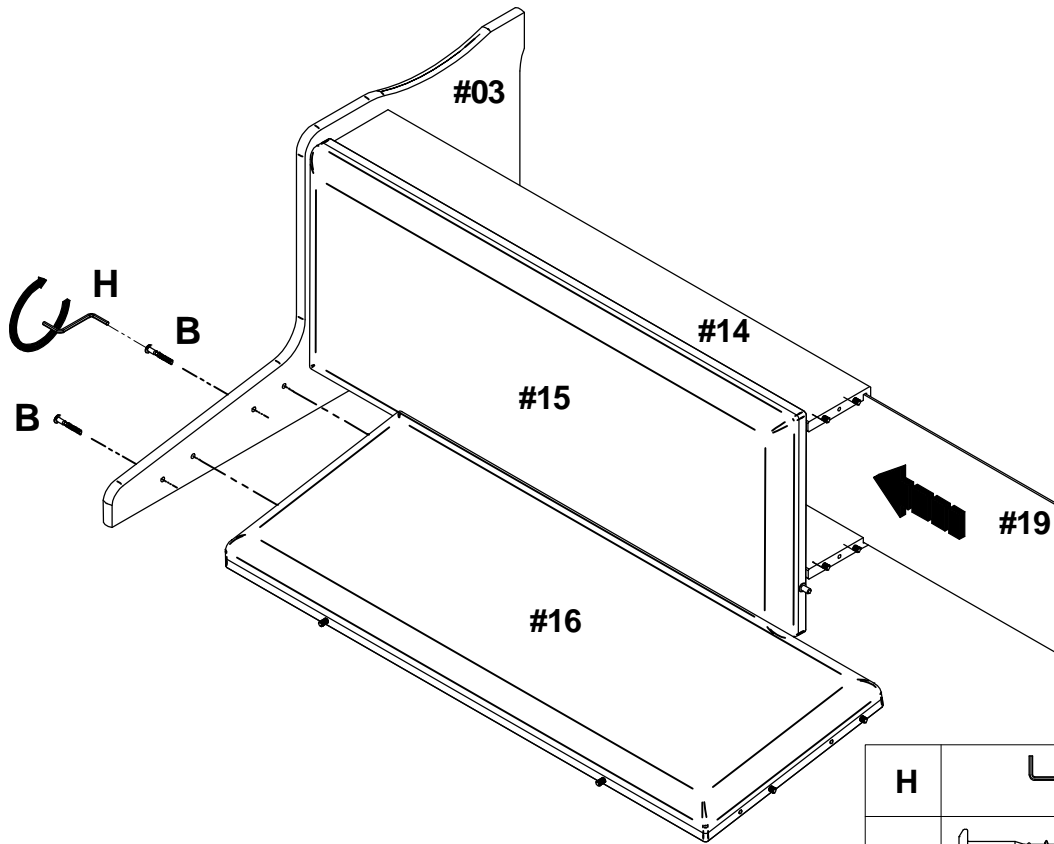

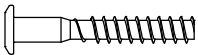
|   |   |    |
|---|---|----|
| H |  | 01 |
| B |  | 02 |

7.

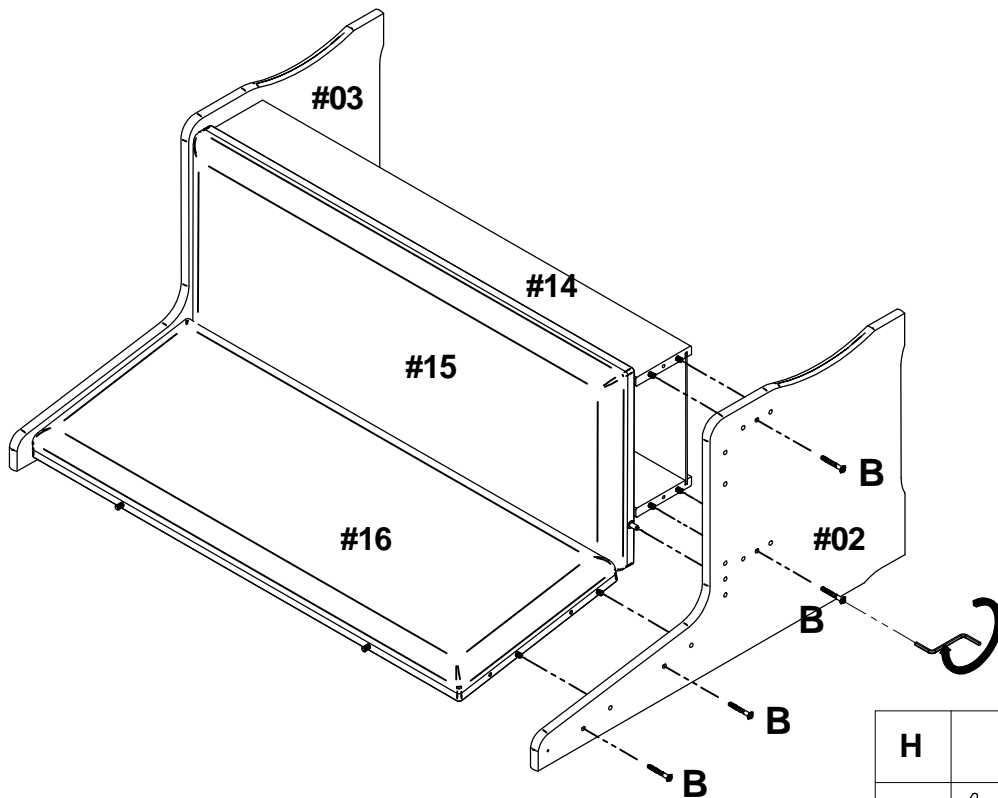

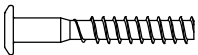
|   |   |    |
|---|---|----|
| H |  | 01 |
| B |  | 04 |

8.

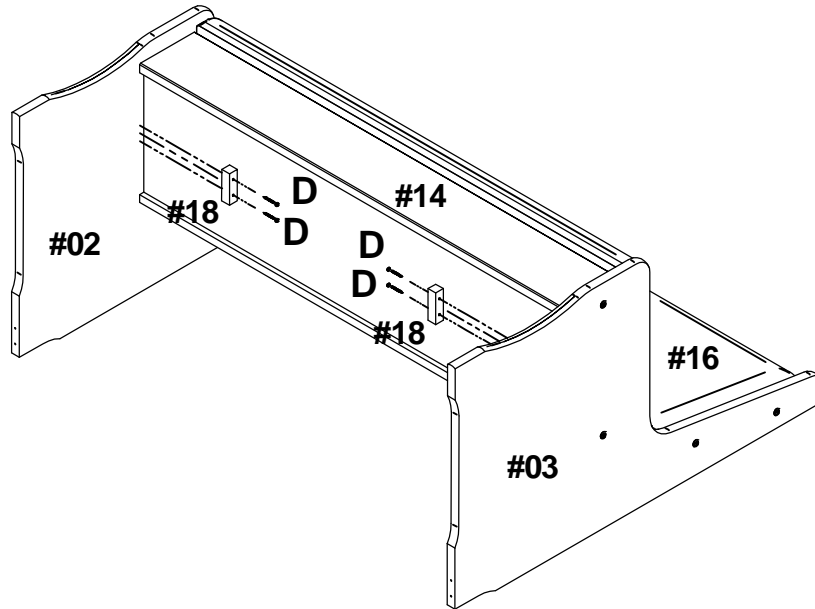

|   |   |    |
|---|---|----|
| D |  | 04 |
|---|---|----|

9.

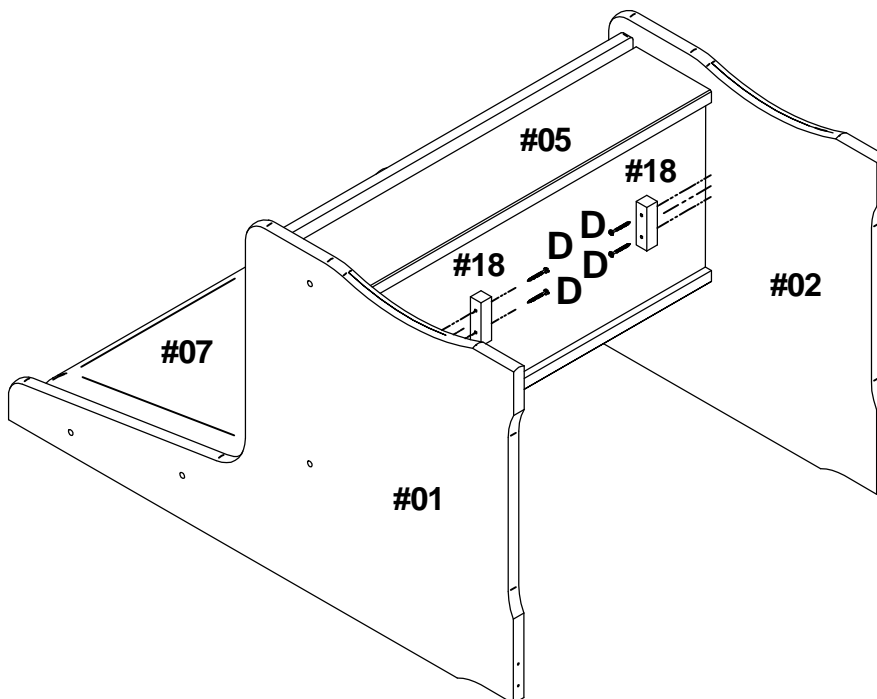

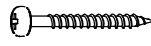
|   |   |    |
|---|---|----|
| D |  | 04 |
|---|---|----|

10.

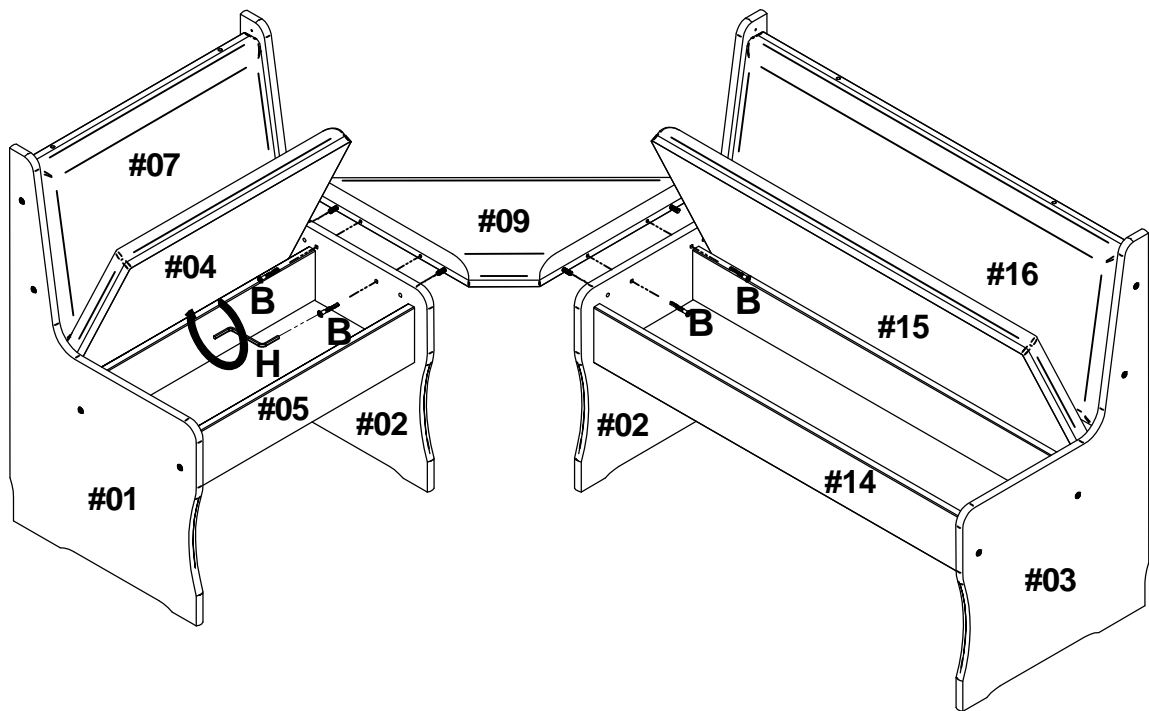

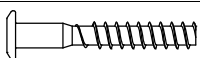

|   |   |    |
|---|---|----|
| H |  | 01 |
| B |  | 04 |

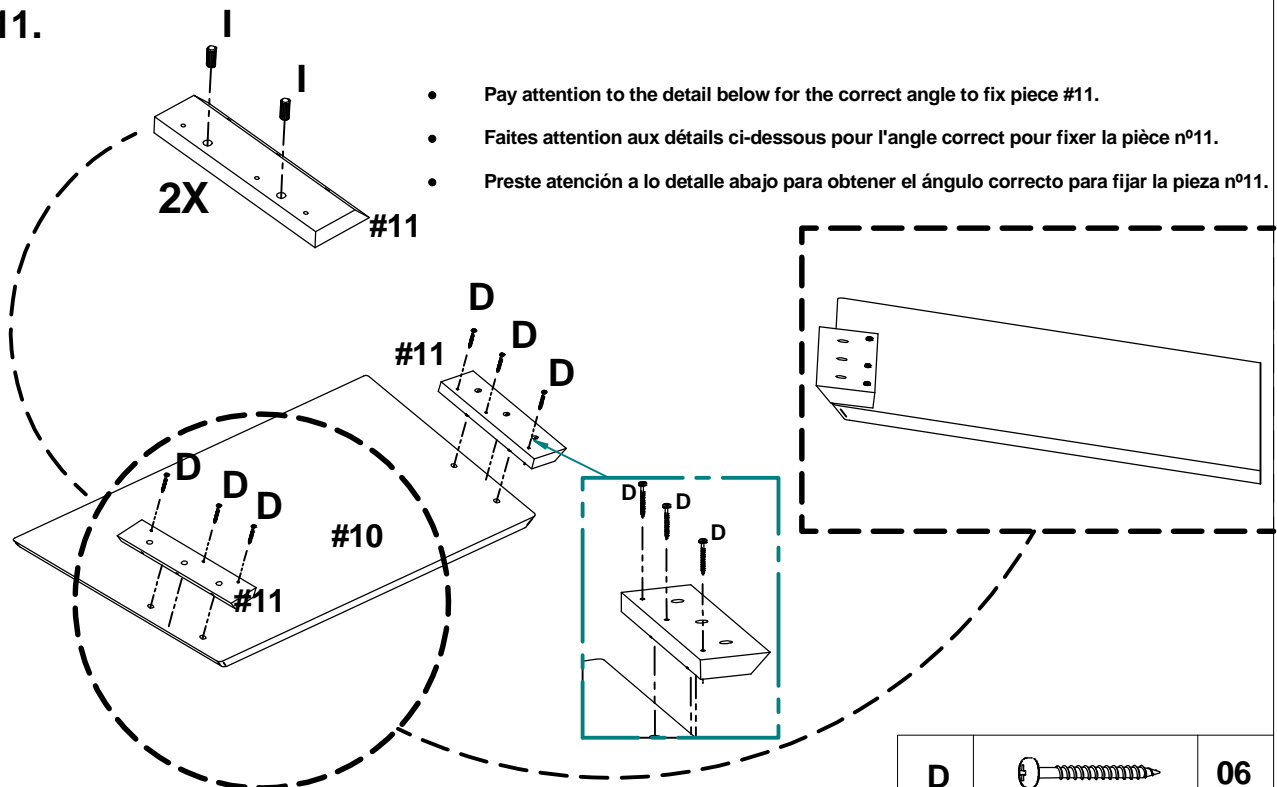
11.

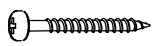

- Pay attention to the detail below for the correct angle to fix piece #11.
- Faites attention aux détails ci-dessous pour l'angle correct pour fixer la pièce n°11.
- Preste atención a lo detalle abajo para obtener el ángulo correcto para fijar la pieza n°11.

|   |   |    |
|---|---|----|
| D |  | 06 |
| I |  | 04 |

12.

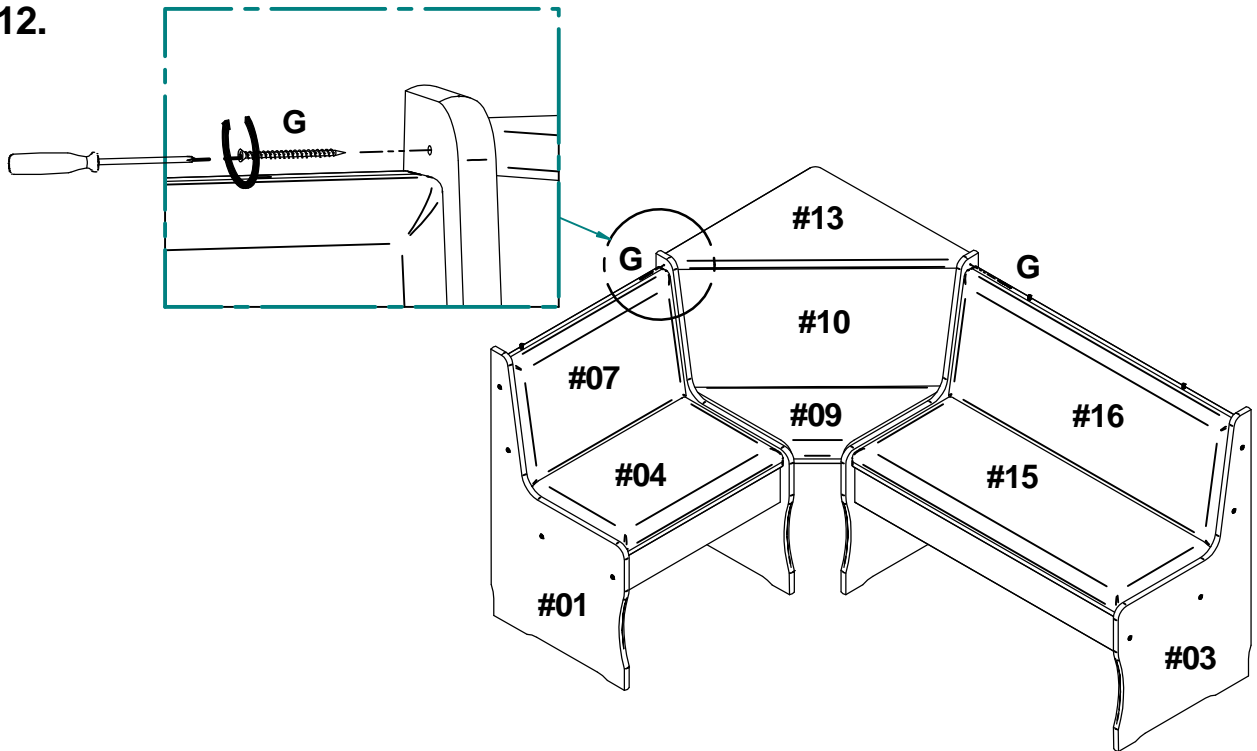

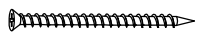
|   |   |    |
|---|---|----|
| G |  | 02 |
|---|---|----|

13.

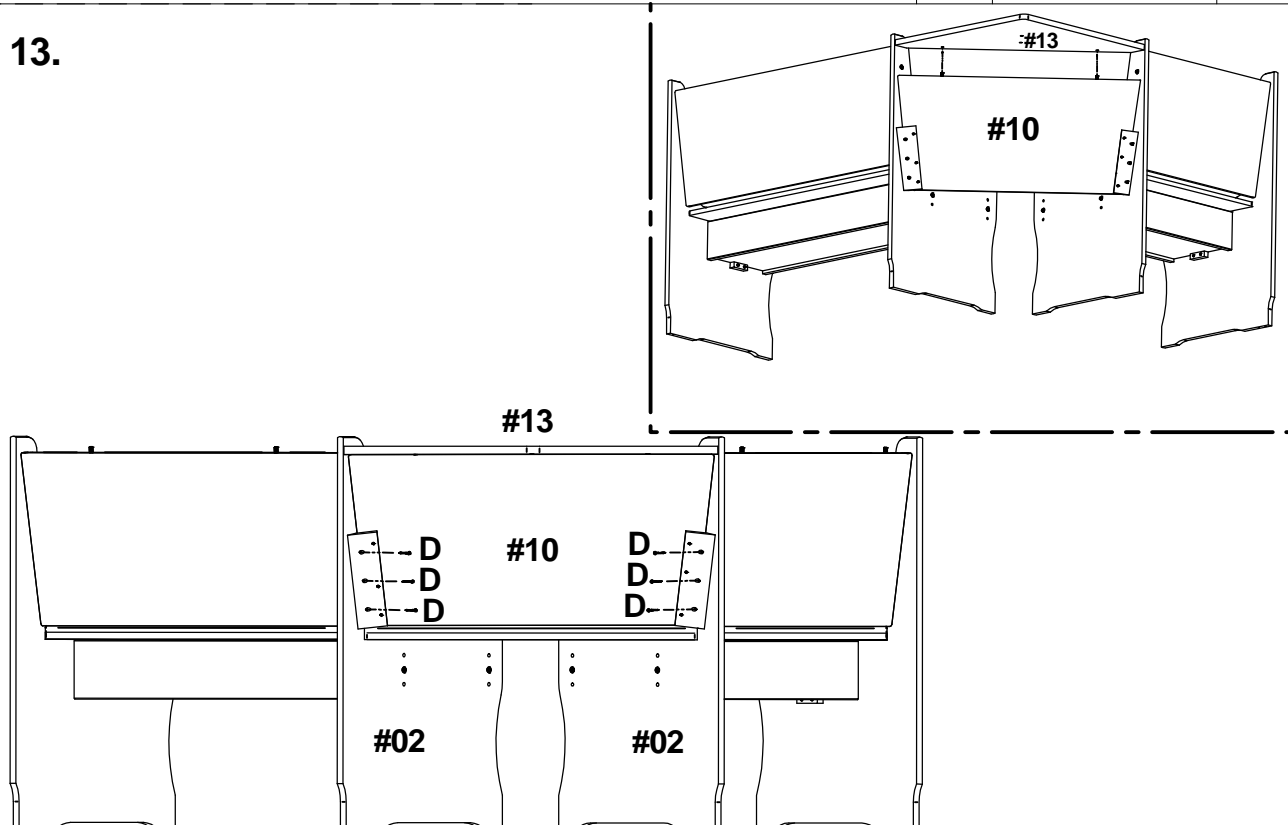

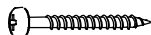
|   |   |    |
|---|---|----|
| D |  | 06 |
|---|---|----|

14.

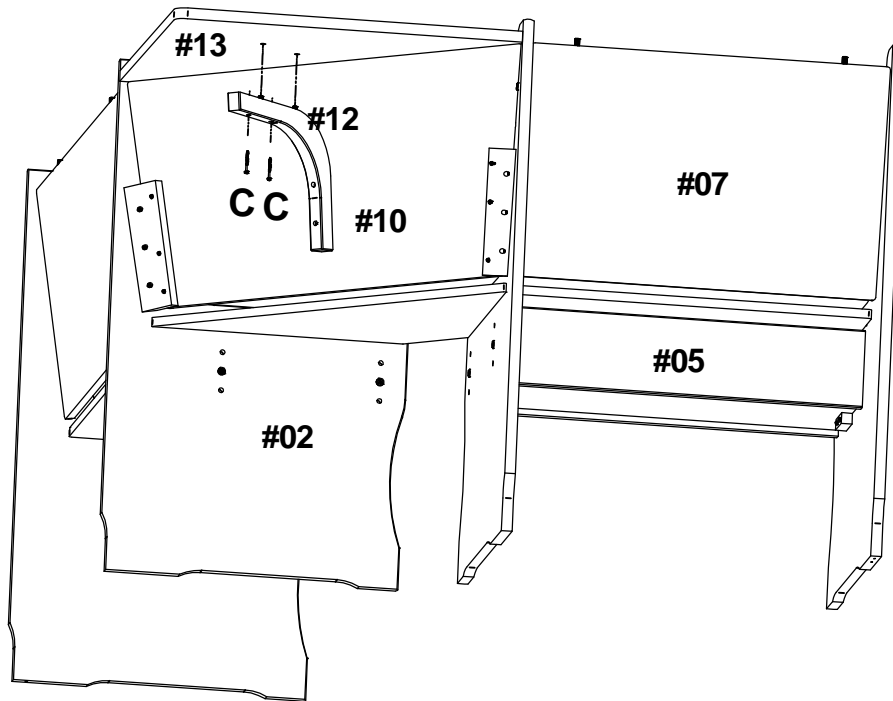

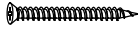
|   |   |    |
|---|---|----|
| C |  | 02 |
|---|---|----|

15.

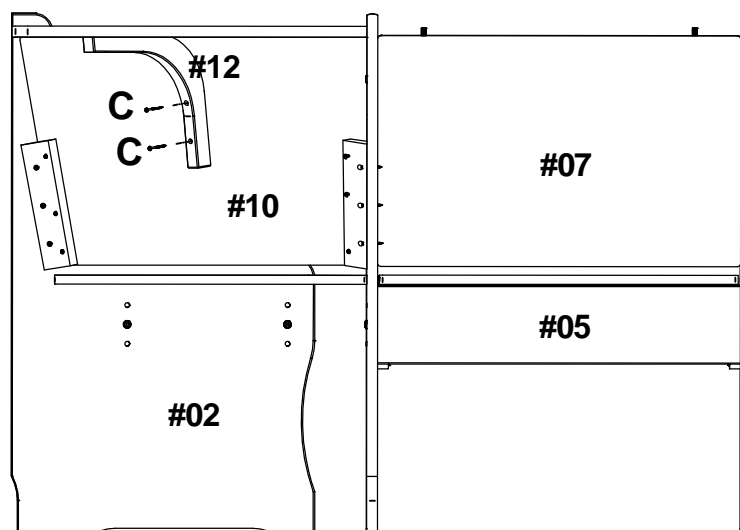

|   |   |    |
|---|---|----|
| C |  | 02 |
|---|---|----|

16.

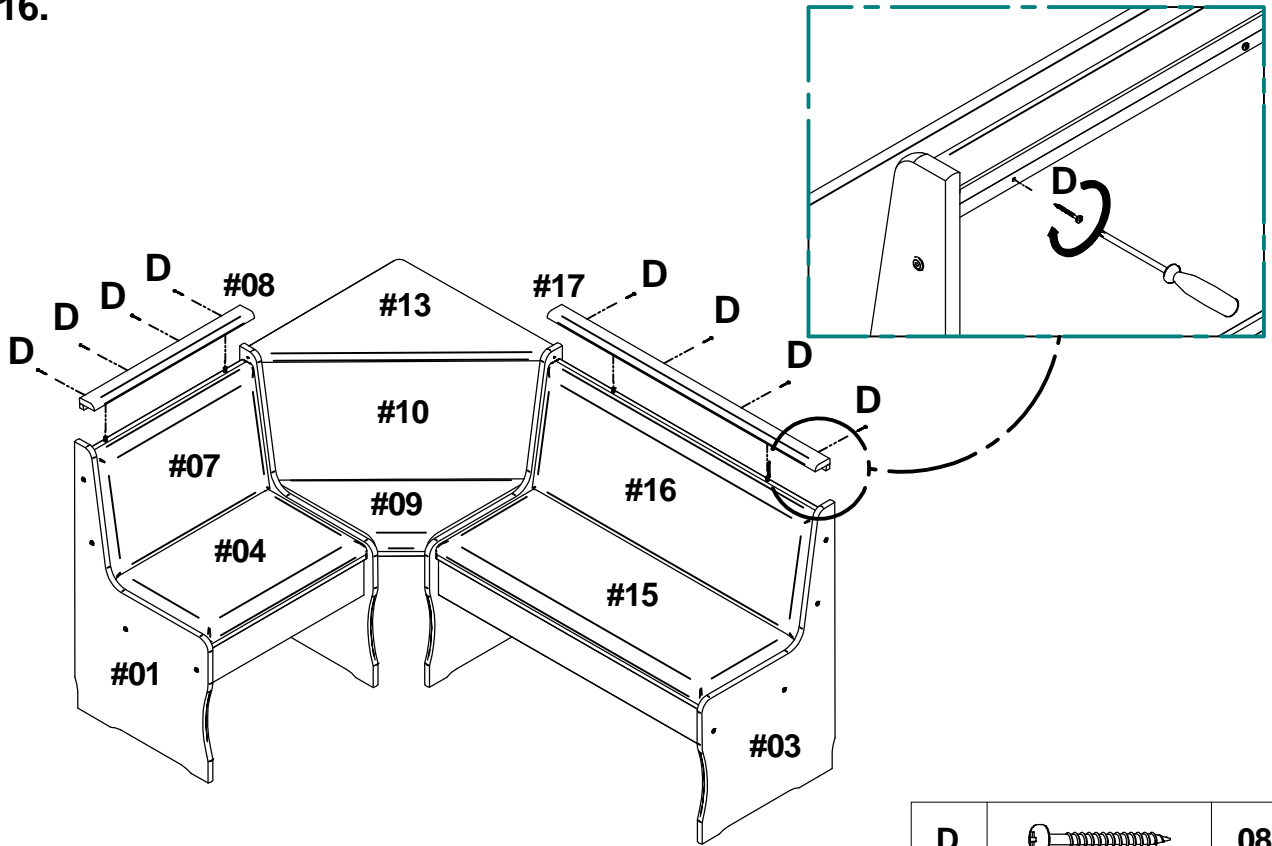

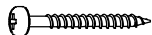
|   |   |    |
|---|---|----|
| D |  | 08 |
|---|---|----|

17.

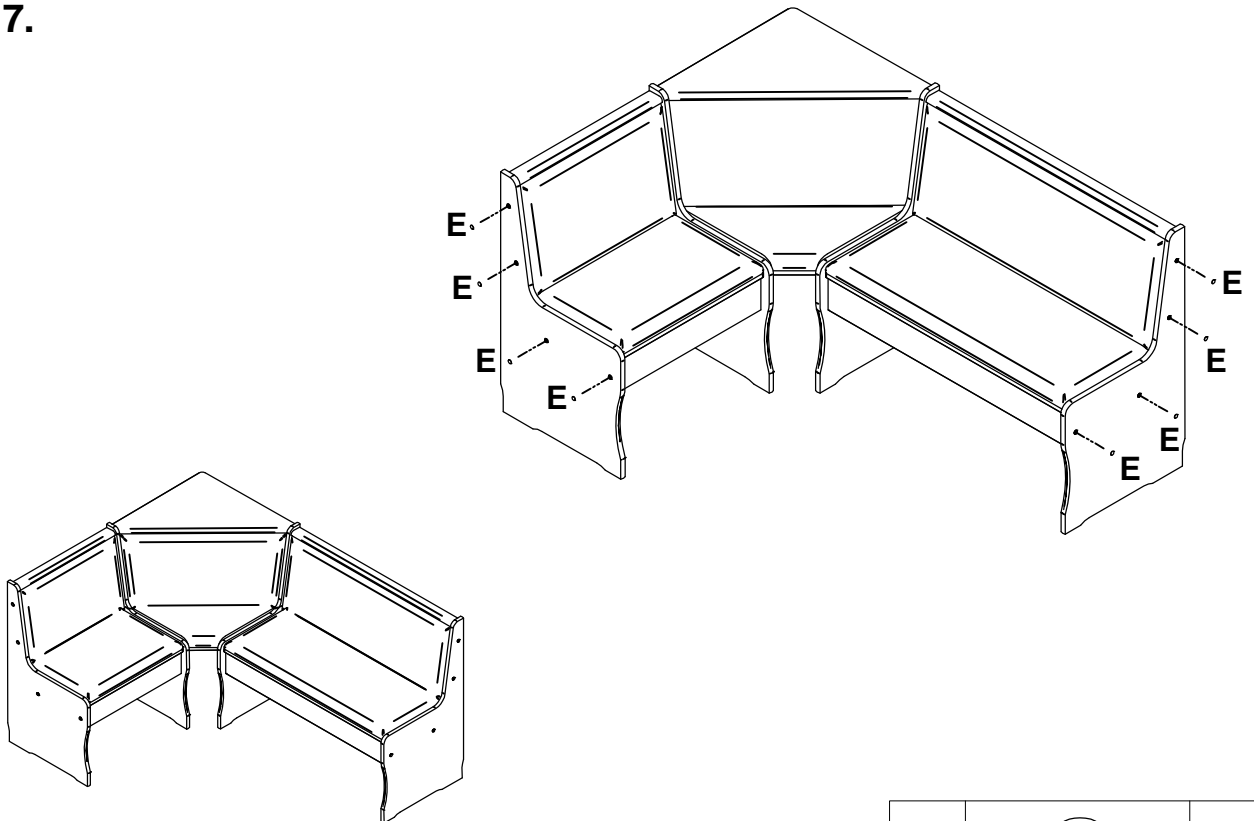



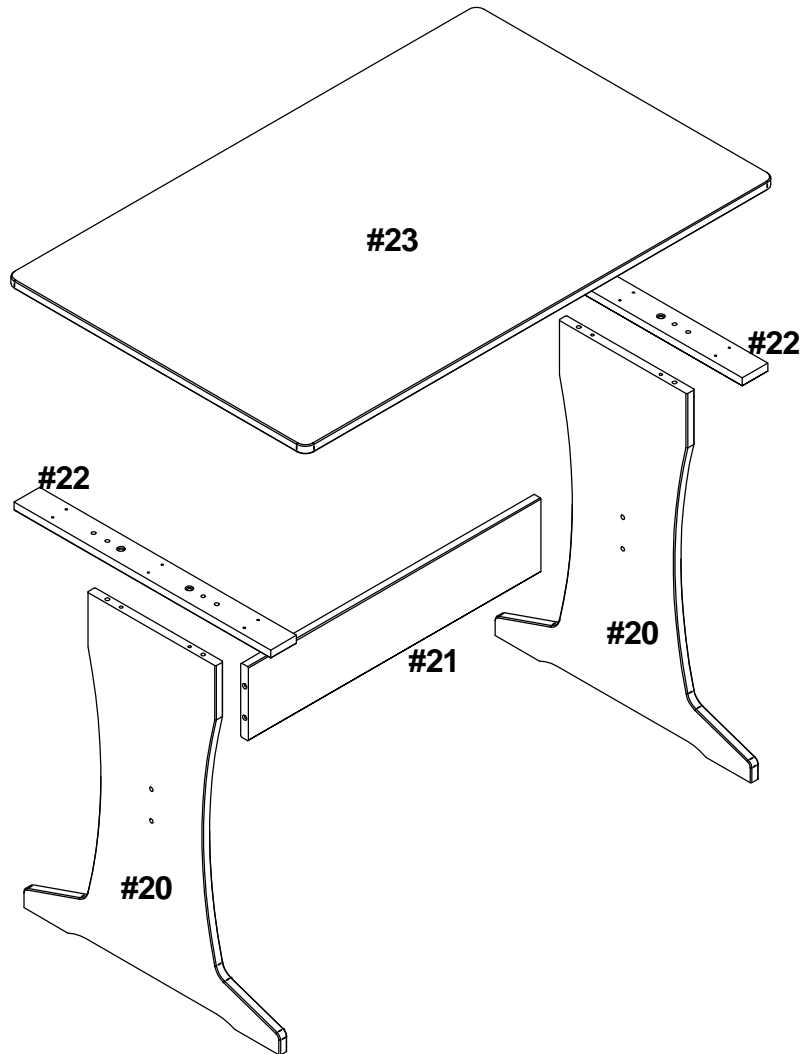

|   |   |    |
|---|---|----|
| E |  | 08 |
|---|---|----|

## Part list / Liste des pièces / Lista de piezas

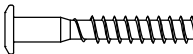

| Description  | Qty. |
|--|------|
| Legs / Pied / Patas                                    | 02   |
| Crossbar / Barre transversale / Travessaño             | 01   |
| Table top support / Support de table / Suporte de mesa | 02   |
| Table top / Dessus de la table / Tablero de mesa       | 01   |
| Table hardware pack / Ferrures / Paquete de herraje    | 01   |

HARDWARE PACKAGE - TABLE / PAQUET DE FERRURES - TABLE / PAQUETE DE HERRAGE - MESA

|   |   |   |    |
|---|---|---|----|
| A | Wood dowel (8x30) / Goujons de bois / Tarugo de madeira |  | 04 |
| B | Bolt (7x50mm) / Boulon / Tornillo                       |  | 08 |
| C | Wood dowel (8x20) / Goujons de bois / Tarugo de madeira |  | 04 |
| D | Screw (3,5x30mm) / Vis / Tornillo                       |  | 12 |
| E | Screw cap / Bouchon à vis / Tapón de tornillo           |  | 04 |
| F | Felt / Feutre / Fieltro                                 |  | 04 |
| G | Allen wrench / Clé allen / Llave allen                  |  | 01 |

**Tools required / Outils requis / Herramientas requeridas**

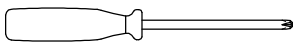
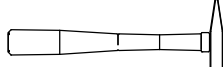
|  |  |  |
|--|--|--|
| <b>Philips screwdriver / Tournevis Philips / Destornillador estándar</b> |  | <b>Not supplied / Non fourni / No incluido</b> |
| <b>Hammer / Marteau / Martillo</b>                                       |  | <b>Not supplied / Non fourni / No incluido</b> |

**IMPORTANT:**

1. Do not tighten bolts completely until all bolts are completely lined up and inserted into holes / nuts.
2. Do not over tighten screws and bolts to avoid stripping.
3. Please use hand tools to assemble this product. Do not use power tools.

**IMPORTANT:**

1. Ne serraz pas complètement les boulons jusqu'à ce que tous les boulons soient complètement alignés et insérés dans les trous / écrous.
2. Ne pas trop serrer les vis et les boulons pour éviter d'endommager les filets.
3. Utilisez des outils à main pour assembler ce produit. N' utilisez pas d'outils électriques.

**IMPORTANTE:**

1. No apriete completamente los pernos hasta que todos los tornillos estén alineados completamente y se inserten en los agujeros / tuercas.
2. No apriete demasiado los tornillos y los pernos para evitar dañar los filetes.
3. Utilice herramientas de mano para montar este producto. No utilice herramientas eléctricas.

**USE / MANTINENCE**

1. Indoor use only.
2. Wipe clean with damp cloth.

**UTILISER / MAINTENANCE**



1. Doit être utilisé à l'intérieur seulement.
2. Nettoyez avec un linge humide.

**USO / MANTENIMIENTO**

1. Solamente usar en espacios internos.
2. Limpiar con un trapo húmedo.

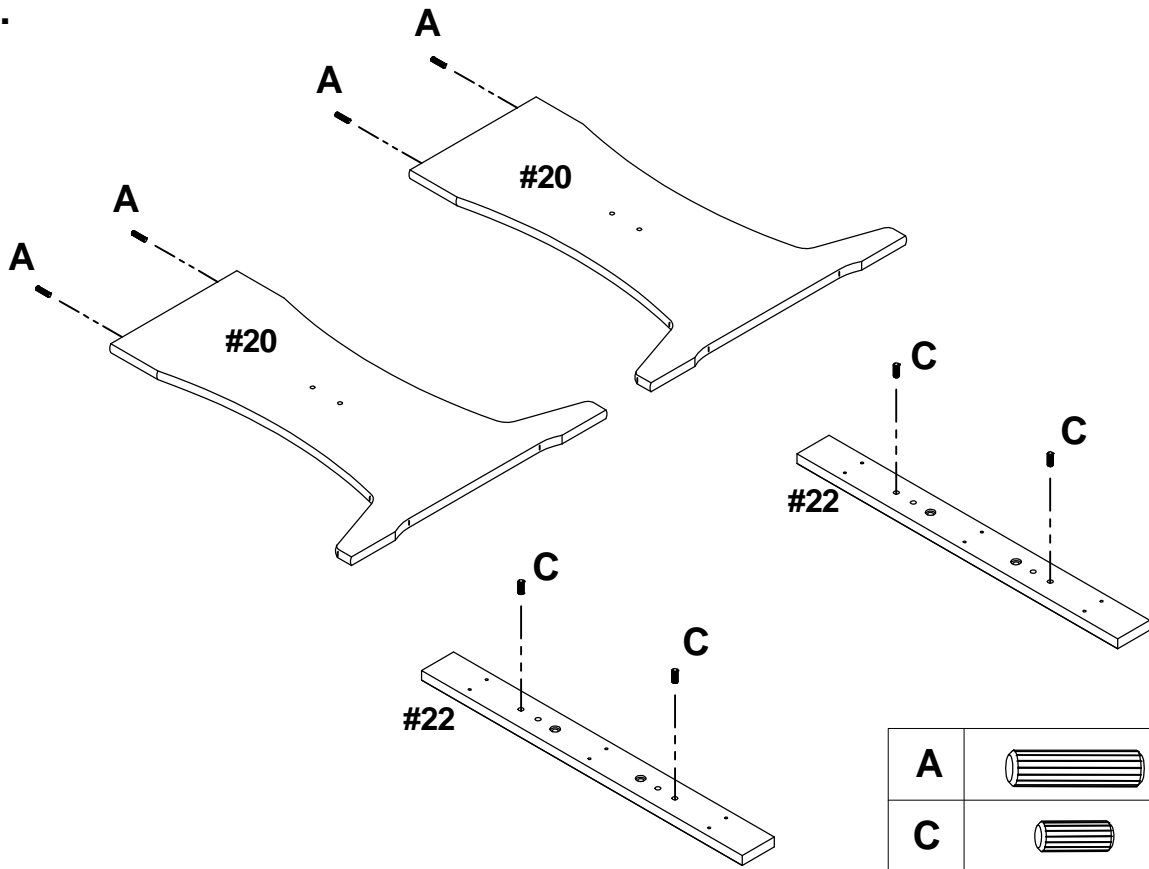
1.



|   |   |    |
|---|---|----|
| A |  | 04 |
| C |  | 04 |

2.

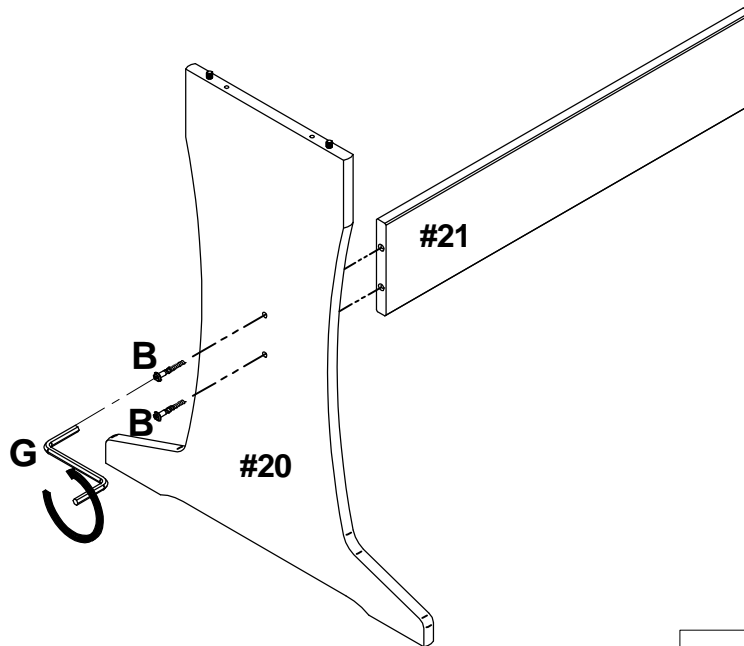

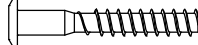
|   |   |    |
|---|---|----|
| G |  | 01 |
| B |  | 02 |

3.

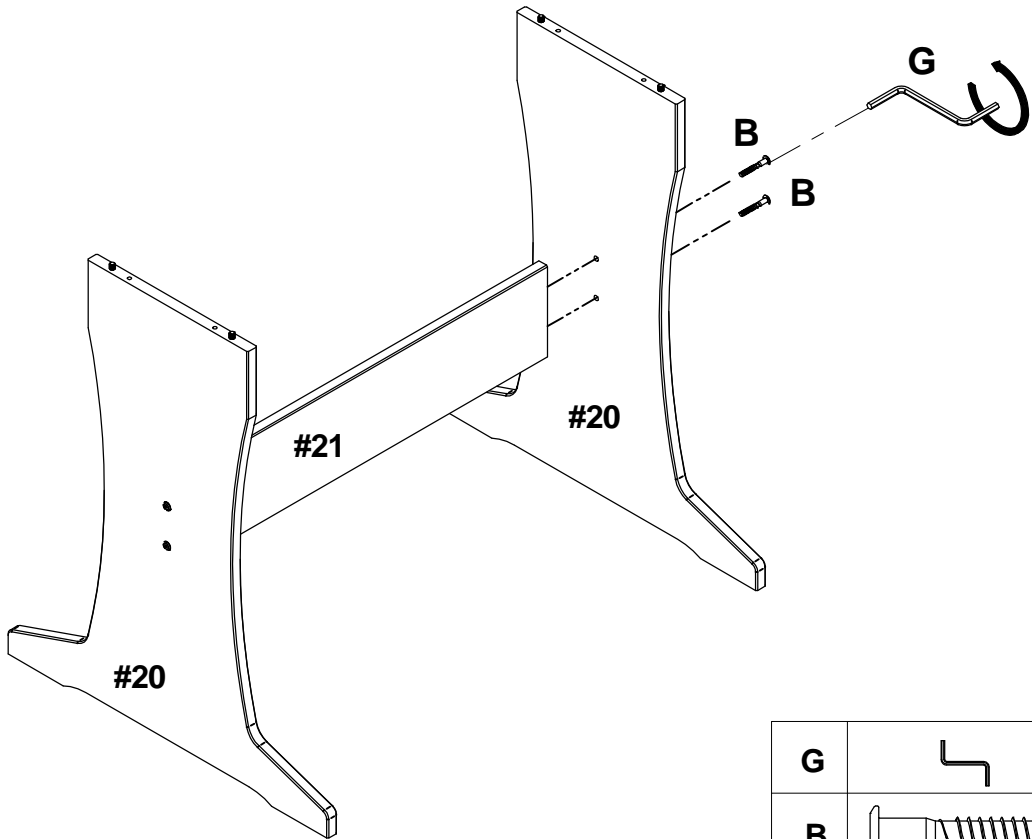

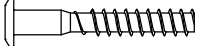
|   |   |    |
|---|---|----|
| G |  | 01 |
| B |  | 02 |

4.

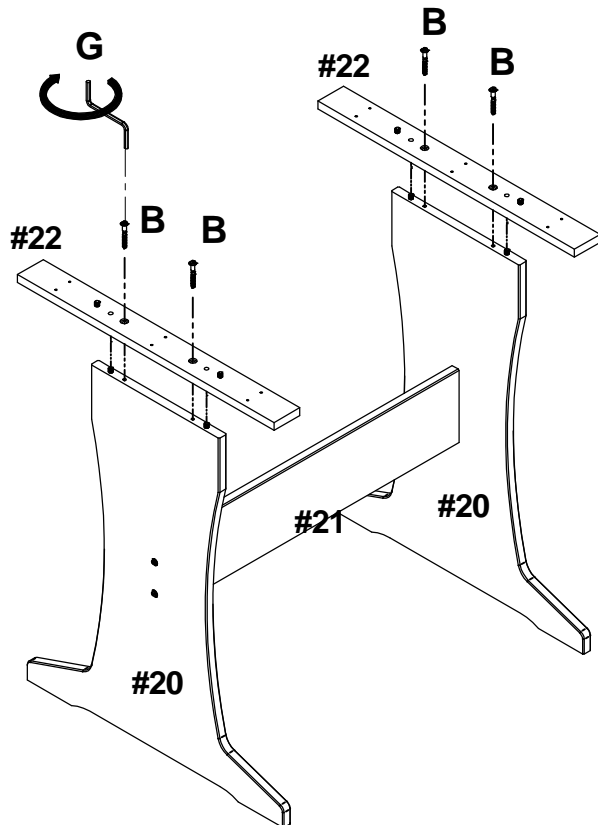

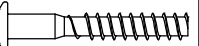
|   |   |    |
|---|---|----|
| G |  | 01 |
| B |  | 04 |

5.

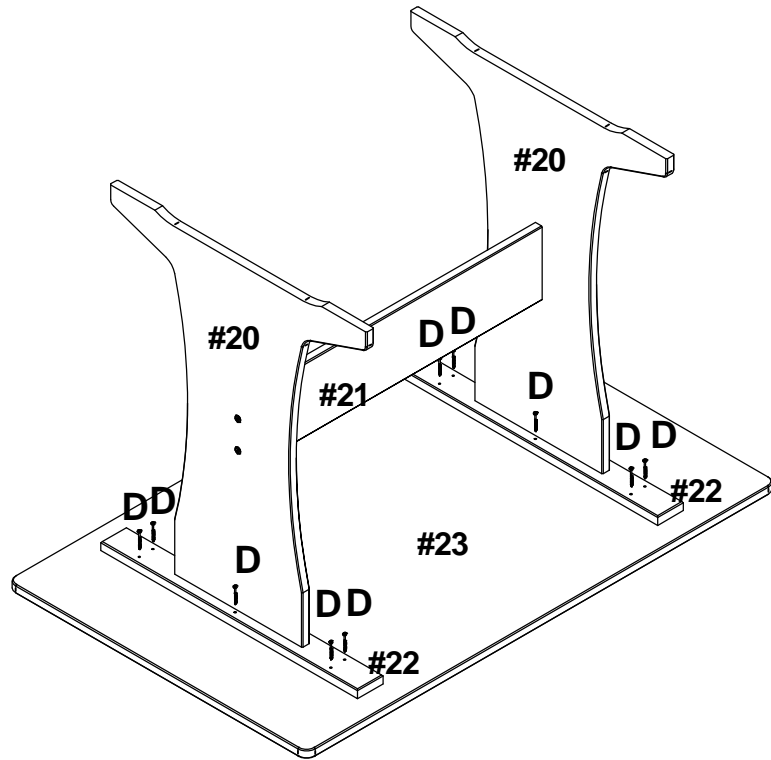

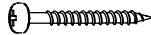
|   |   |    |
|---|---|----|
| D |  | 12 |
|---|---|----|

6.

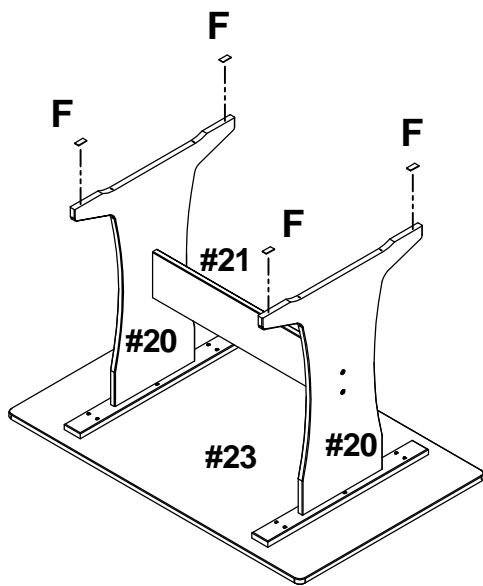

|   |   |    |
|---|---|----|
| F |  | 04 |
|---|---|----|

7.

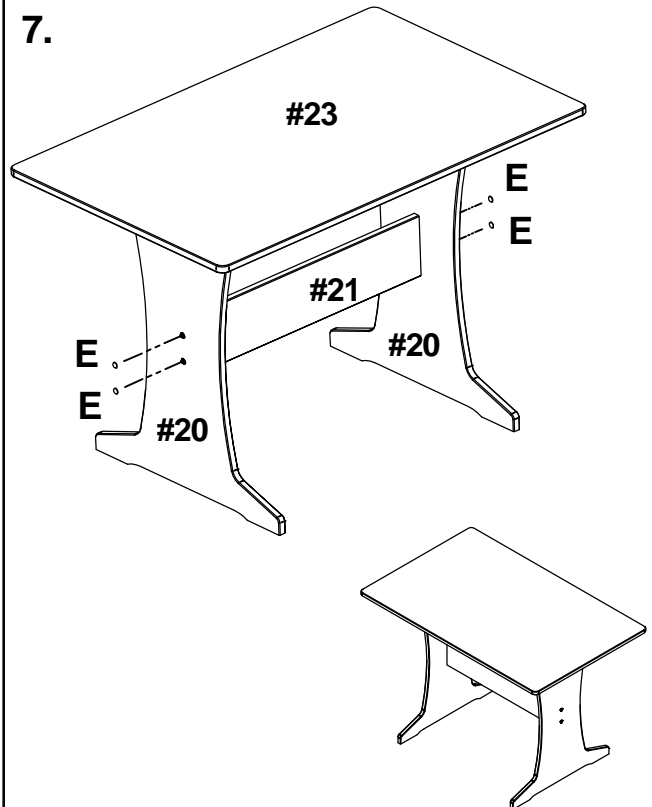

|   |   |    |
|---|---|----|
| E |  | 04 |
|---|---|----|

**Part list / Liste des pièces / Lista de piezas**

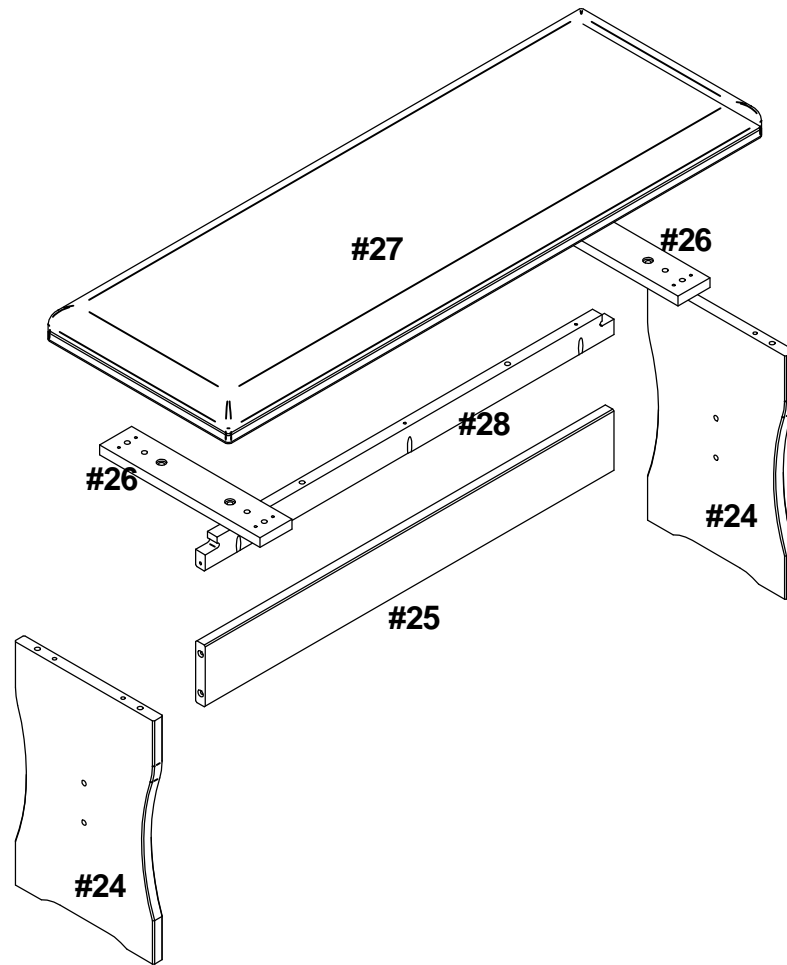

| Description  | Qty. |
|--|------|
| Legs / Pied / Patas  | 02   |
| Crossbar / Barre transversale / Travessaño                 | 01   |
| Seat support / Support de siège / Soporte de asiento       | 02   |
| Seat / Siège / Asiento                                     | 01   |
| Rail / Rail Riel   | 01   |
| Simple bench hardware pack / Ferrures / Paquete de herraje | 01   |

**HARDWARE PACKAGE - SIMPLE BENCH / PAQUET DE FERRURES - BANC SIMPLE / PAQUETE DE HERRAGE - BANCO SIMPLE**

|          |  |  |           |
|----------|--|--|-----------|
| <b>A</b> | <b>Wood dowel (8x30) / Goujons de bois / Tarugo de madeira</b> |  | <b>06</b> |
| <b>B</b> | <b>Bolt (7x50mm) / Boulon / Tornillo</b>                       |  | <b>08</b> |
| <b>C</b> | <b>Wood dowel (8x20) / Goujons de bois / Tarugo de madeira</b> |  | <b>04</b> |
| <b>D</b> | <b>Screw (3,5x30mm) / Vis / Tornillo</b>                       |  | <b>13</b> |
| <b>E</b> | <b>Screw cap / Bouchon à vis / Tapón de tornillo</b>           |  | <b>04</b> |
| <b>F</b> | <b>Felt / Feutre / Fieltro</b>                                 |  | <b>04</b> |
| <b>G</b> | <b>Allen wrench / Clé allen / Llave allen</b>                  |  | <b>01</b> |

**Tools required / Outils requis / Herramientas requeridas**

|  |  |  |
|--|--|--|
| <b>Philips screwdriver / Tournevis Philips / Destornillador estándar</b> |  | <b>Not supplied / Non fourni / No incluido</b> |
| <b>Hammer / Marteau / Martillo</b>                                       |  | <b>Not supplied / Non fourni / No incluido</b> |

**IMPORTANT:**

1. Do not tighten bolts completely until all bolts are completely lined up and inserted into holes / nuts.
2. Do not over tighten screws and bolts to avoid stripping.
3. Please use hand tools to assemble this product. Do not use power tools.

**IMPORTANT:**

1. Ne serrez pas complètement les boulons jusqu'à ce que tous les boulons soient complètement alignés et insérés dans les trous / écrous.
2. Ne pas trop serrer les vis et les boulons pour éviter d'endommager les filets.
3. Utilisez des outils à main pour assembler ce produit. N' utilisez pas d'outils électriques.

**IMPORTANTE:**

1. No apriete completamente los pernos hasta que todos los tornillos estén alineados completamente y se inserten en los agujeros / tuercas.
2. No apriete demasiado los tornillos y los pernos para evitar dañar los filetes.
3. Utilice herramientas de mano para montar este producto. No utilice herramientas eléctricas.

**USE / MANTINENCE**

1. Indoor use only.
2. Wipe clean with damp cloth.

**UTILISER / MAINTENANCE**

1. Doit être utilisé à l'intérieur seulement.
2. Nettoyez avec un linge humide.

**USO / MANTENIMIENTO**

1. Solamente usar en espacios internos.
2. Limpiar con un trapo húmedo.

1.

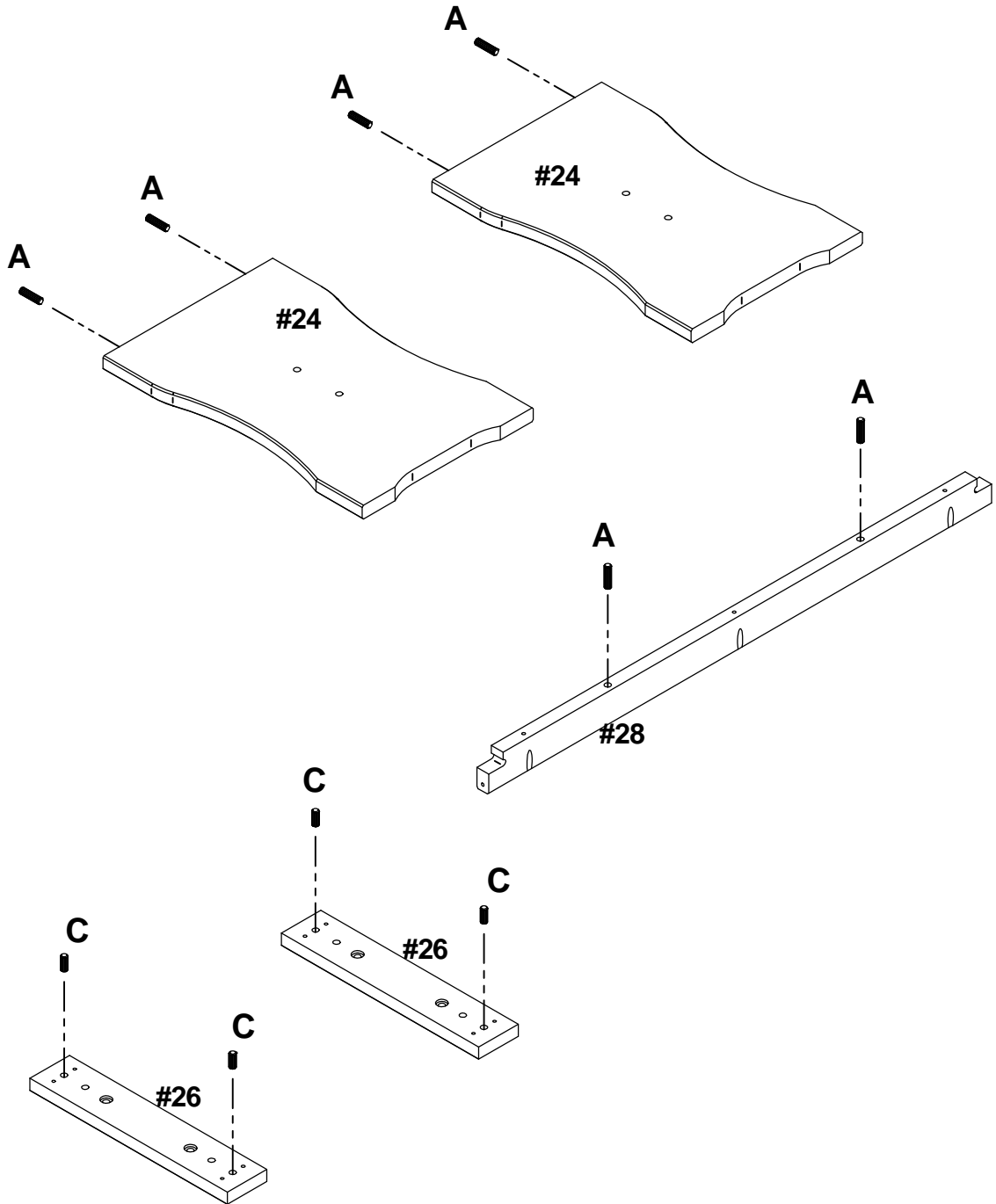

|          |  |           |
|----------|--|-----------|
| <b>A</b> |  | <b>06</b> |
| <b>C</b> |  | <b>04</b> |

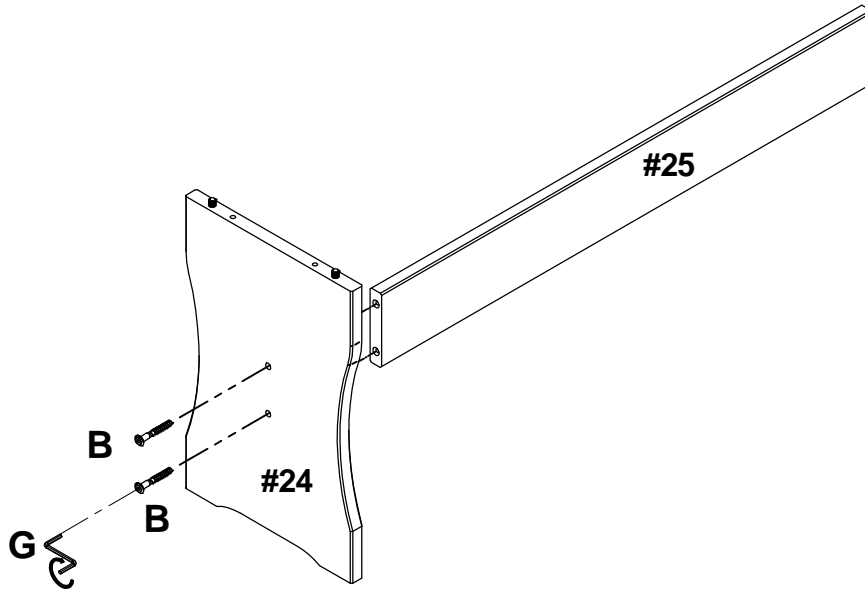

2.

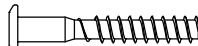

|   |   |    |
|---|---|----|
| G |  | 01 |
| B |  | 02 |

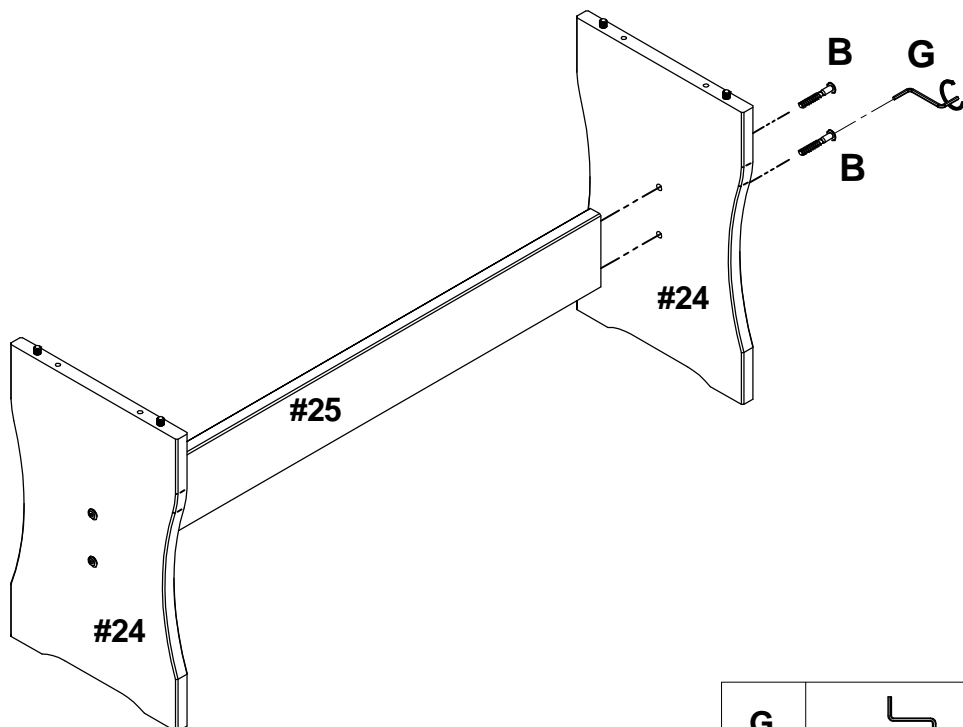
3.



|   |   |    |
|---|---|----|
| G |  | 01 |
| B |  | 02 |

4.

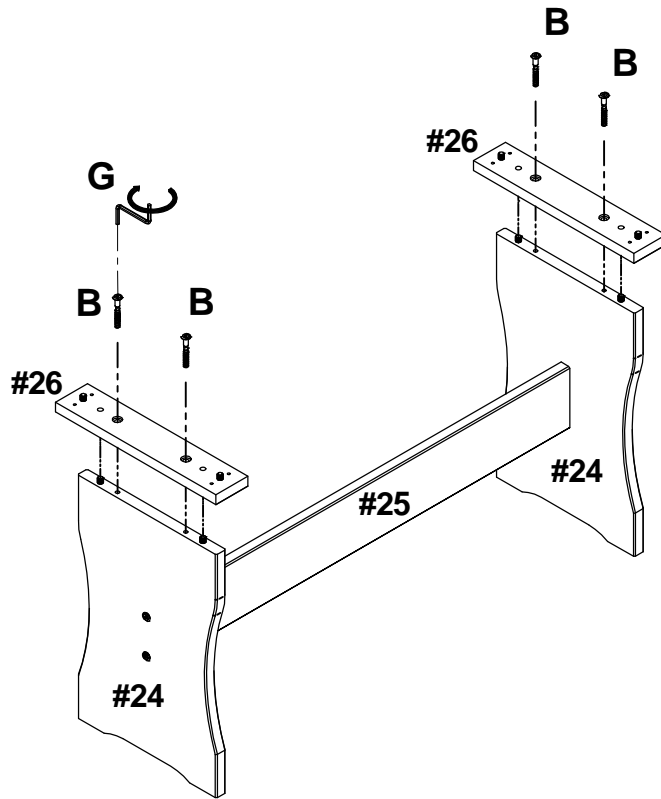

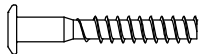

|   |   |    |
|---|---|----|
| G |  | 01 |
| B |  | 04 |

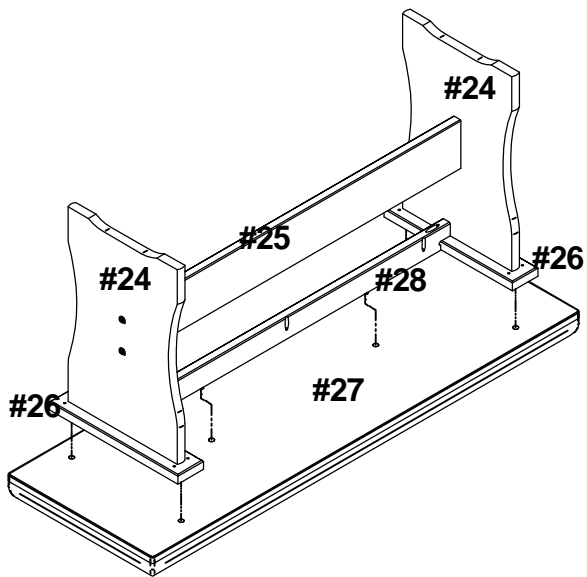
5.



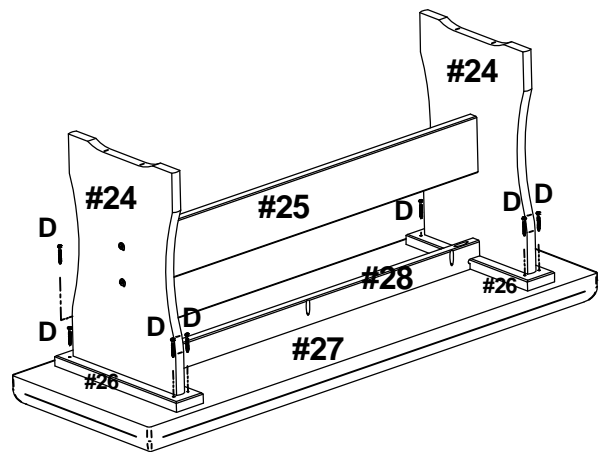

6.

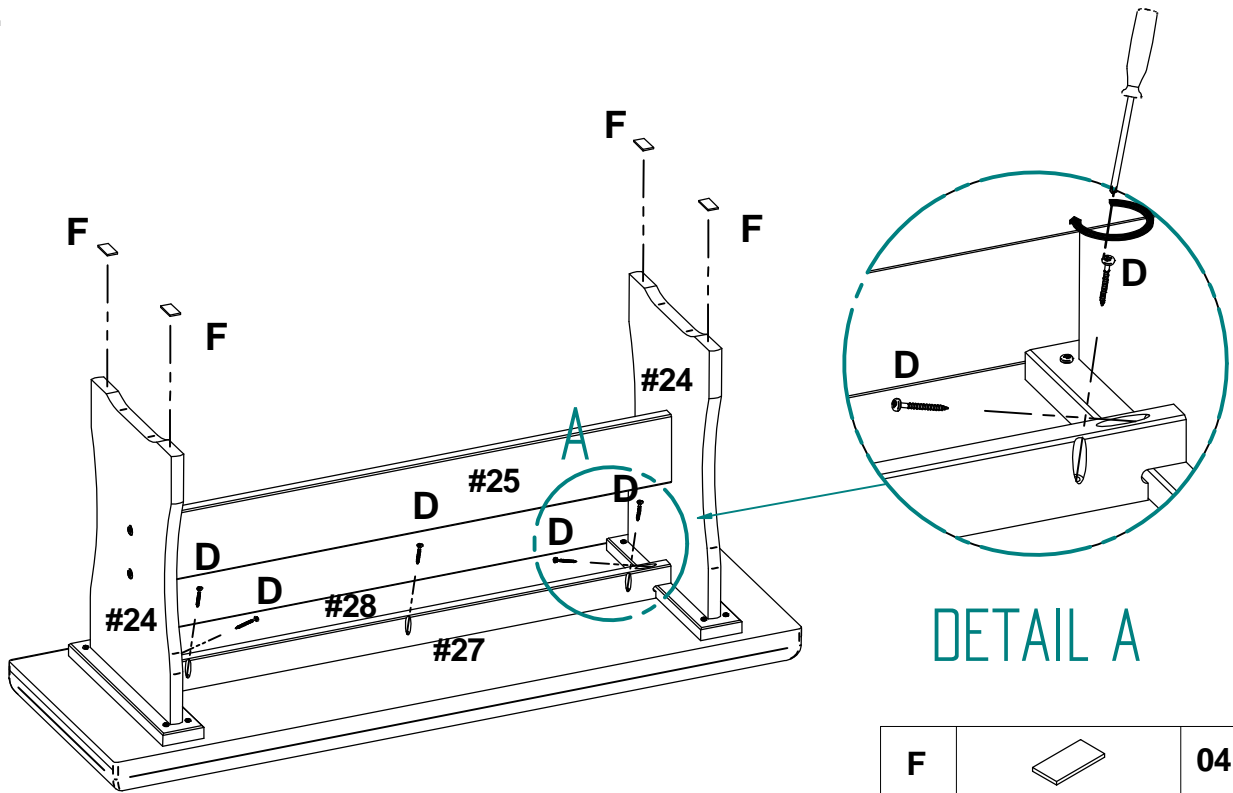

|   |   |    |
|---|---|----|
| D |  | 08 |
|---|---|----|

7.



|   |   |    |
|---|---|----|
| F |  | 04 |
| D |  | 05 |

8.

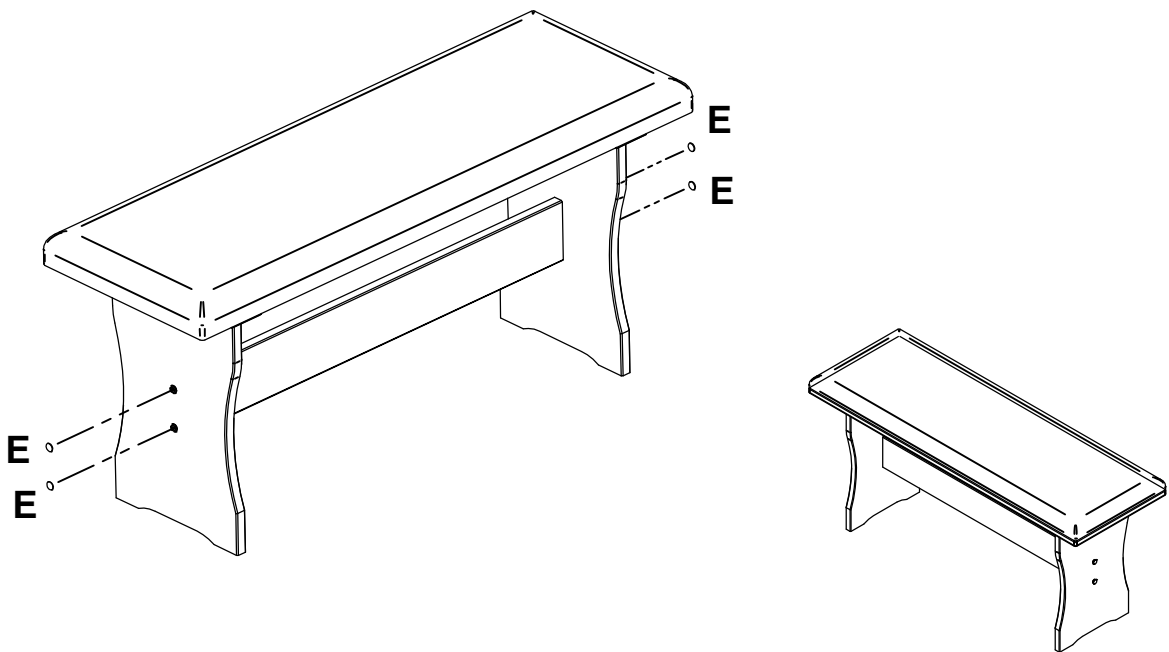

|   |   |    |
|---|---|----|
| E |  | 04 |
|---|---|----|

**LIMITED 6 MONTHS WARRANTY**  
**GARANTIE LIMITÉE DE 6 MOIS**  
**GARANTÍA LIMITADA DE 6 MESES**

**WHAT IS COVERED**

This product is covered under our manufacturer's 6 months limited warranty. To ensure your complete satisfaction, this warranty to the original purchaser that the supplied item is free from defects in material and workmanship, as of the date of purchase, and that it will, under normal use and proper care, remain so for six months after the date of purchase.

Replacement of missing or initially defective parts will be sent, at no charge, for a period of 30 days from the date of purchase with valid proof of purchase providing the parts are available in our warehouse and the item purchased is part of our current inventory.

**WHAT IS NOT COVERED**

It remains the customer's responsibility for freight and packaging charges to and from the customer service center. Labor and material charges to remove or replace parts under this warranty are not covered.

This warranty does not cover: Furniture used for commercial purposes, failures caused by improper installation assembly or by improper care, unreasonable or abusive use, freeze damage, acts of God, rust, purchased parts or returns freight and packaging charges. Proof of purchase (dated register receipt) is

required for warranty claims.

**QU'EST-CE QUI EST COUVERT**

Ce produit est couvert sous une garantie limitée de 6 mois offerte par le fabricant. Afin d'assurer votre entière satisfaction, cela garantit à l'acheteur original que le produit fourni est exempt de défauts de matériaux et de fabrication à compter de la date d'achat, et ce, sous des conditions d'utilisation normales et de soins adéquats, valide pendant six mois après la date d'achat.

Le remplacement de pièces manquantes ou défectueuses dès le départ sera envoyé, sans frais, pour une période de 30 jours suivant la date d'achat avec une preuve d'achat valide pourvu que les pièces soient disponibles dans notre entrepôt et que l'article acheté fait partie de notre inventaire actuel.

**QU'EST-CE QUI N'EST PAS COUVERT**

Il y a de la responsabilité du client de couvrir les frais de transport et d'emballage vers et à partir du centre de service après-vente. Les frais de la main-d'oeuvre et des matériaux pour retirer les pièces ou les remplacer sous cette garantie ne sont pas couverts.

Cette garantie ne couvre pas: les meubles utilisés à des fins commerciales, les défaillances causées par un mauvais assemblage ou entretien (sans dépasser les limites de poids), l'utilisation déraisonnable ou abusive, les dommages causés par le gel, la rouille, les frais de transport et d'emballage pour des pièces achetées ou retournées. Une preuve d'achat (reçu de caisse daté) est requise pour les réclamations sous garantie.

**QUÉ ESTÁ CUBIERTO**

Este producto está cubierto por la garantía limitada de 6 meses de nuestro fabricante. Para asegurar su total satisfacción, ésta garantiza al comprador original que el artículo proporcionado se encuentra libre de defectos materiales y de fabricación, a partir de la fecha de compra, y que permanecerá en tal estado, sometido a un uso normal y cuidados adecuados, durante los seis meses posteriores a la fecha de la compra.

Las partes faltantes o que presenten defectos al inicio de ese período de tiempo serán enviadas sin cargo, durante un lapso de 30 días a partir de la fecha de compra válido, siempre que las partes estén disponibles en nuestro almacén y el artículo adquirido sea parte de nuestro inventario actual.

**QUÉ NO ESTÁ CUBIERTO**

El cliente asumirá los costos de flete y empaque hacia y desde el centro de servicio de cliente. Los cargos de material y mano de obra para extraer o reemplazar partes en el marco de la garantía no están cubiertos.

Esta garantía no cubre: muebles utilizados con fines comerciales, fallas causadas por montaje de instalación inadecuados o uso indebido (se recomienda no exceder los límites de peso), uso no razonable o abusivo, daños por congelación, oxidación, partes compradas, flete de devolución y cargos de empaque. Se exigirá el comprobante de compra (la factura de registro con fecha) para hacer valer la garantía.