

ASSEMBLY INSTRUCTIONS

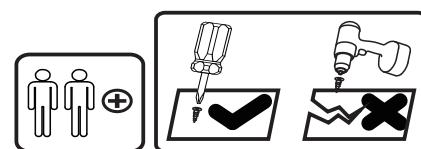
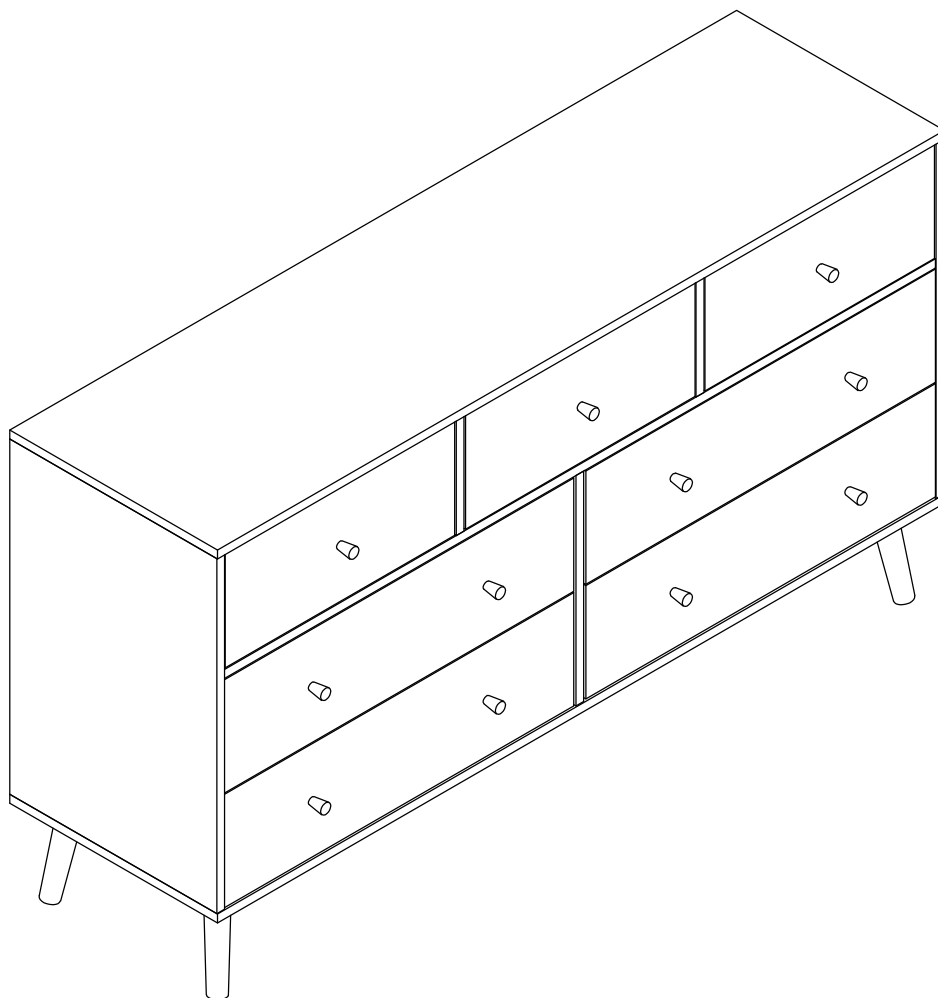

Tools Recommended

THIS INSTRUCTIONS CONTAINS IMPORTANT SAFETY INFORMATION.
PLEASE READ BEFORE ASSEMBLY AND KEEP FOR FUTURE REFERENCE.

IMPORTANT NOTICE

- This product contains small components, please ensure that they are kept away from small children.
- THIS INSTRUCTIONS CONTAINS IMPORTANT SAFETY INFORMATION.
PLEASE READ BEFORE ASSEMBLY AND KEEP FOR FUTURE REFERENCE.
- Read each step carefully. It is very important that each step of instruction is performed in the correct order. If these steps are not followed in sequence, assembly difficulties will occur.
- Make sure all parts are included. Most parts are labelled or stamped on the raw edge.
- Work in spacious area, preferably on a carpet, near the place the unit will be used.
- Do not use power tools to assemble your furniture. Power tools may strip or damage the parts.
- Move your new furniture carefully, with two people lift and carry the unit to it's new location.
- Never push, drag or pull your furniture (especially on carpet)

 WARNING	
	<p>Children have died from furniture tipover. To reduce the risk of furniture tipover:</p> <ul style="list-style-type: none">• ALWAYS install tipover restraint provided.• NEVER put a TV on this product.• NEVER allow children to stand, climb or hang on drawers, doors, or shelves.• NEVER open more than one drawer at a time.• Place heaviest items in the lowest drawers.
	

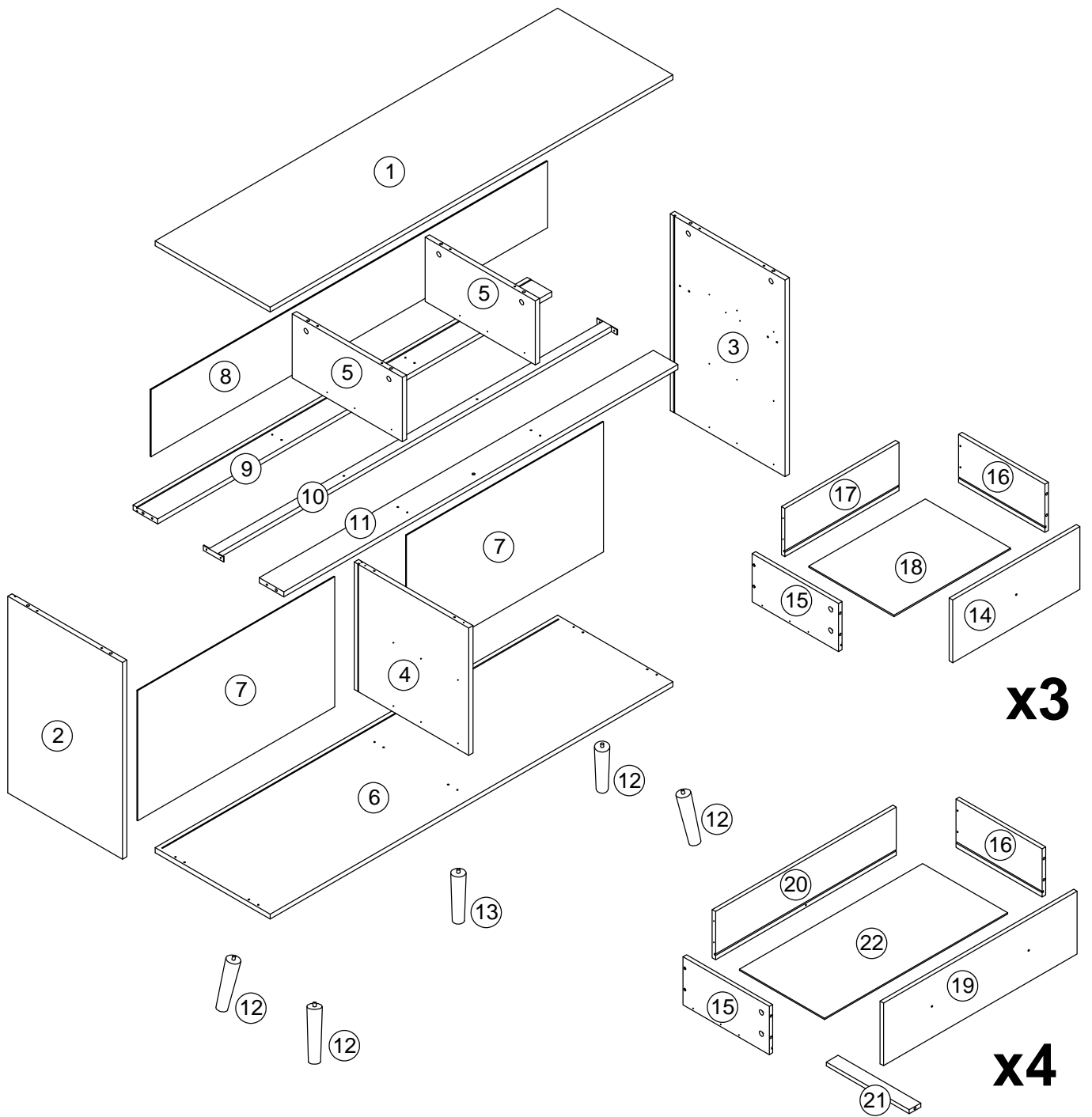

x3

x4

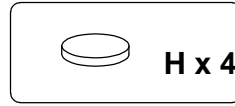
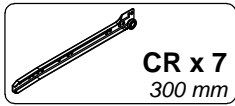
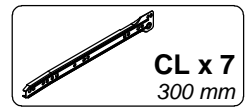
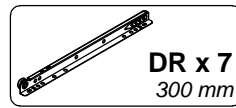
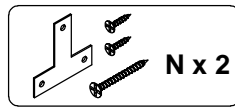
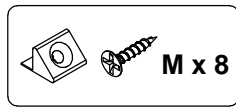
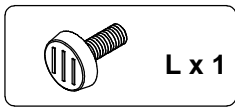
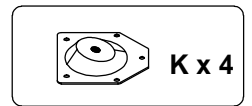
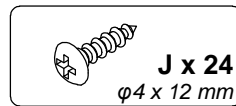
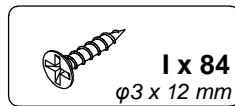
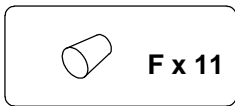
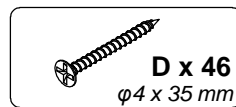
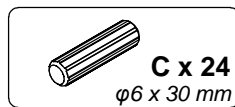
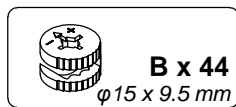
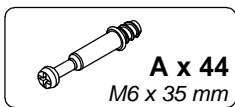

Step 1

Fix left outer drawer runner (CL) and right outer drawer runner (CR) to parts 2 and 3 using screws (I), as shown.

Fix right outer drawer runner (CR) to part 4 and 5 using screws (I), then flipping part 4 and 5 180degrees horizontally to fix left outer drawer runner (CL)

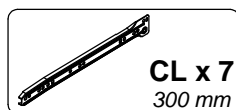
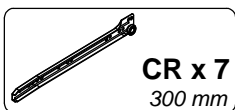
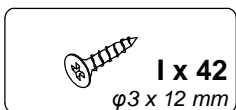
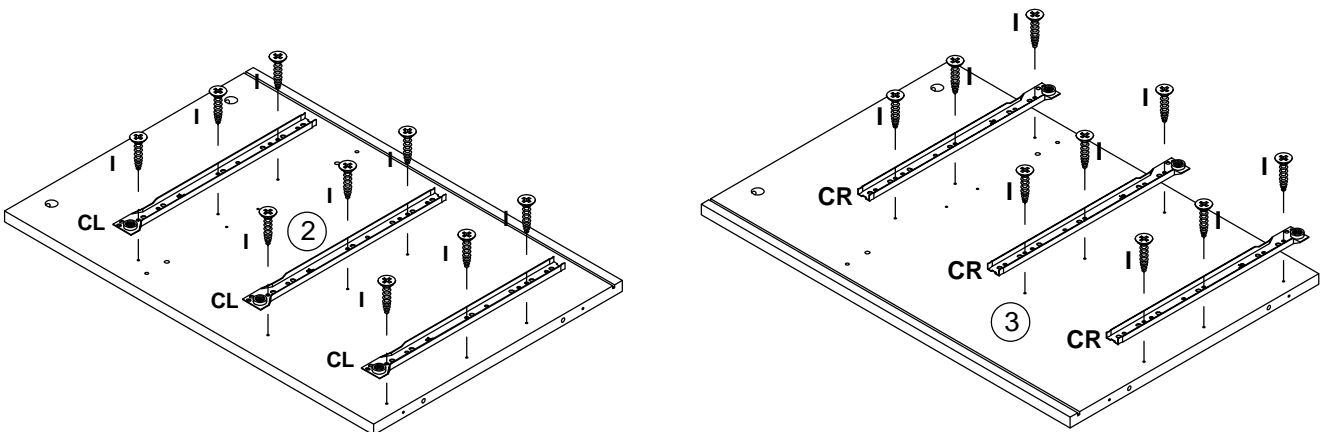
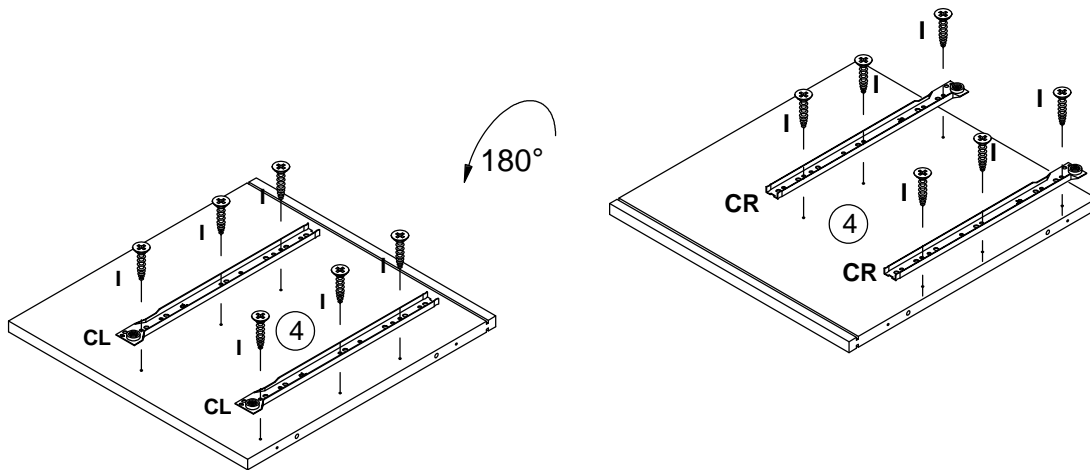
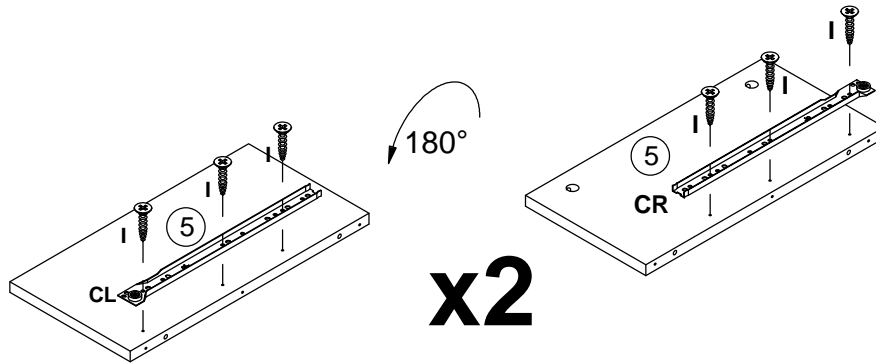
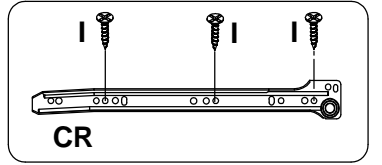
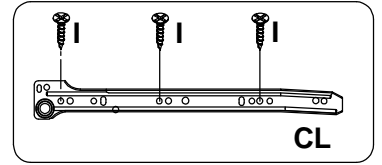

Step 2

Insert wooden dowels (C) into assembled unit, as shown. Attach part 9, 10, 11 to part 5 using screws (D), as shown

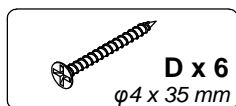
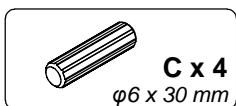
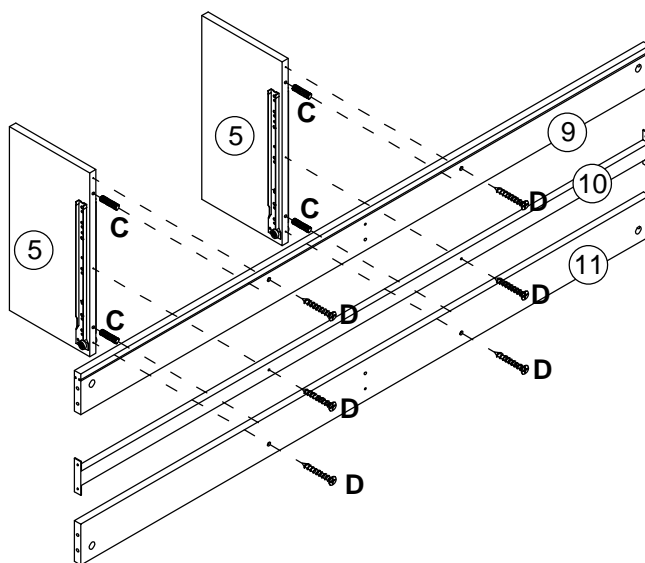

Step 3

Insert wooden dowels (C) into assembled unit, as shown. Attach part 9 and 11 to part 4 using screws (D), as shown

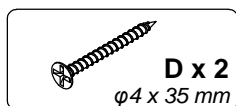
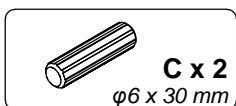
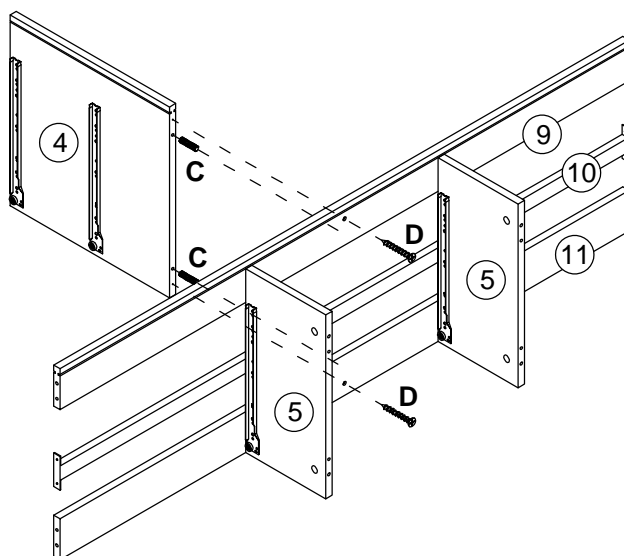

Step 4

Insert screws(A) into part 2 and 3 as shown.

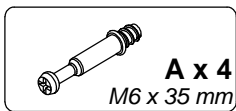
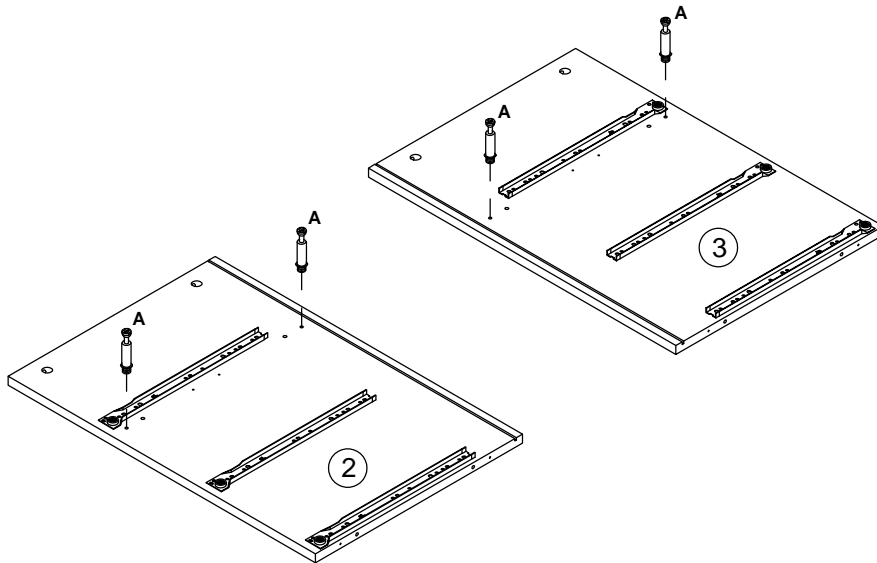

Step 5

Insert cam locks(B) into parts 9, 11 and attach parts 2 and 3 as shown. Turn cam locks clockwise to tighten.

Connect component 10 to components 2 and 3 using screws (J)

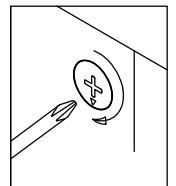
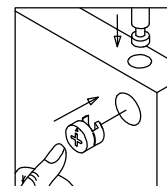
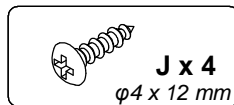
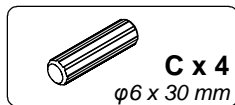
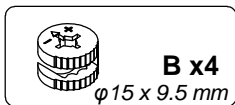
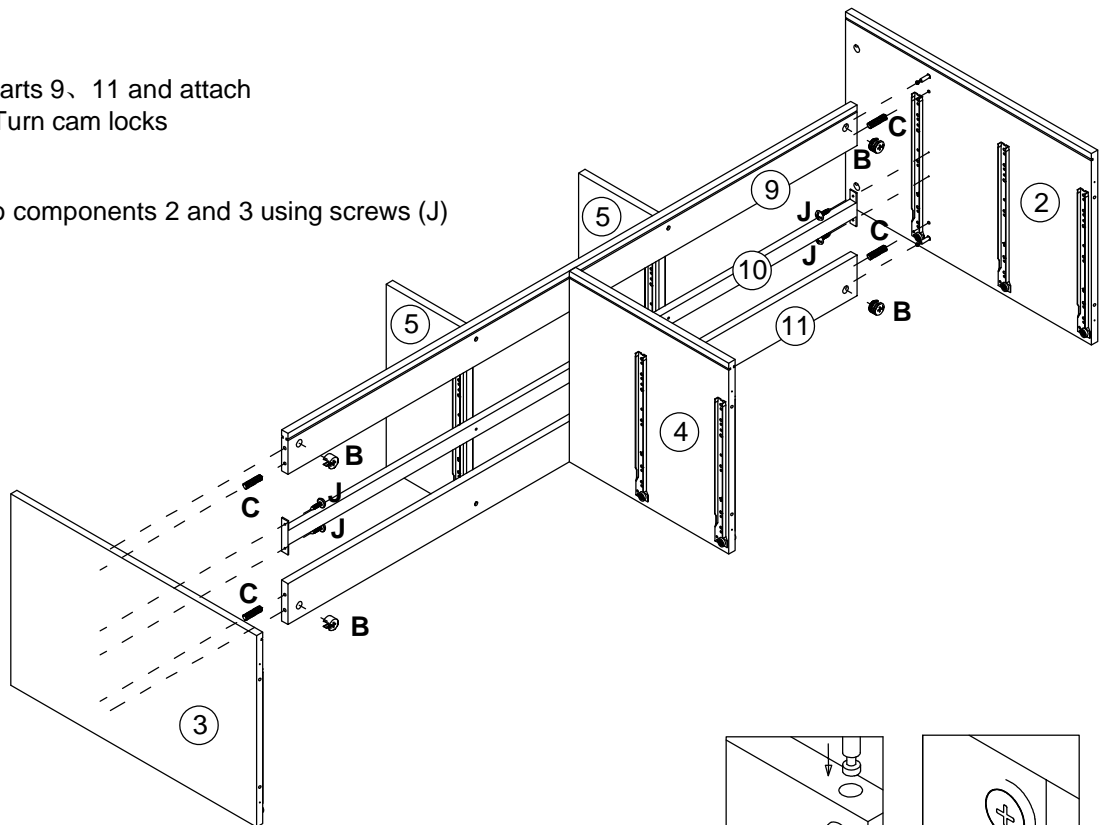

Step 6

Slide part 7 into available slots of parts 2 3 and 4 as shown.
Insert wooden dowels (C) into assembled unit,
as shown. Attach part 6 to assembled unit
using screws (D), as shown

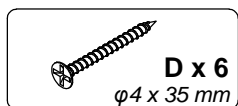
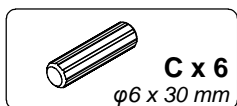
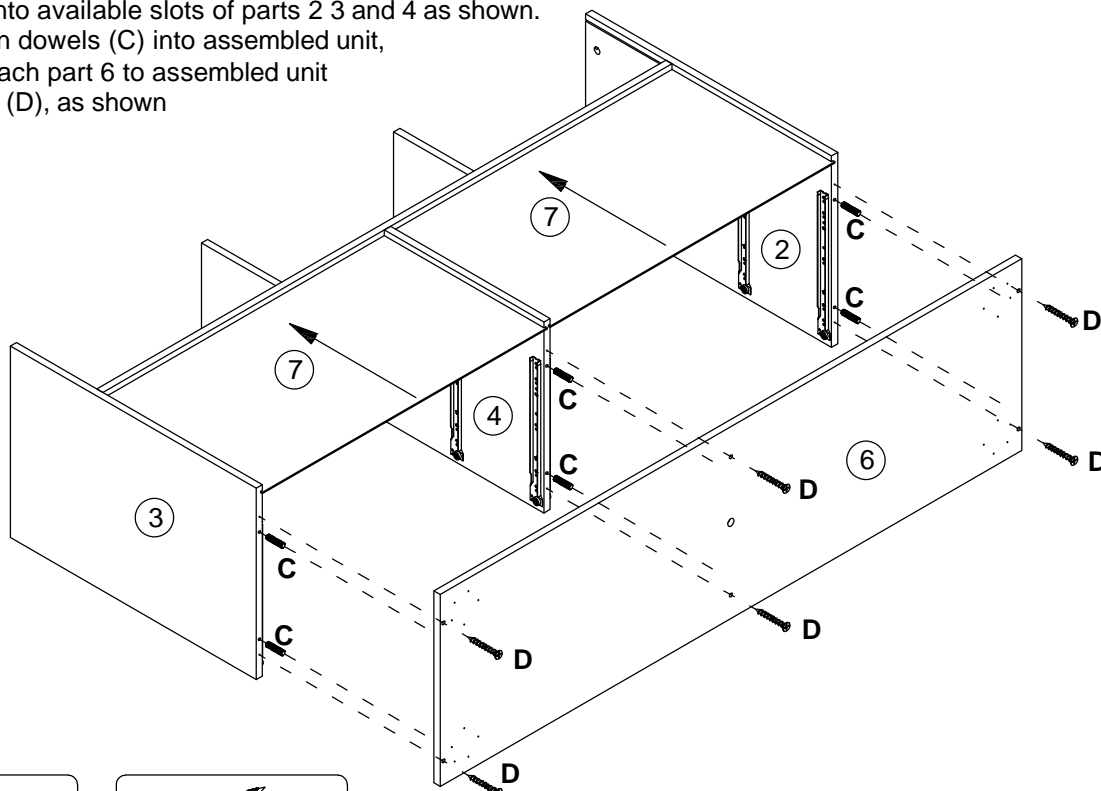

Step 7

Attach legs parts K to the part 6 with bolts (J)

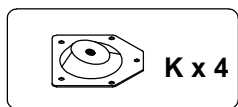
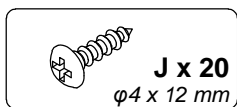
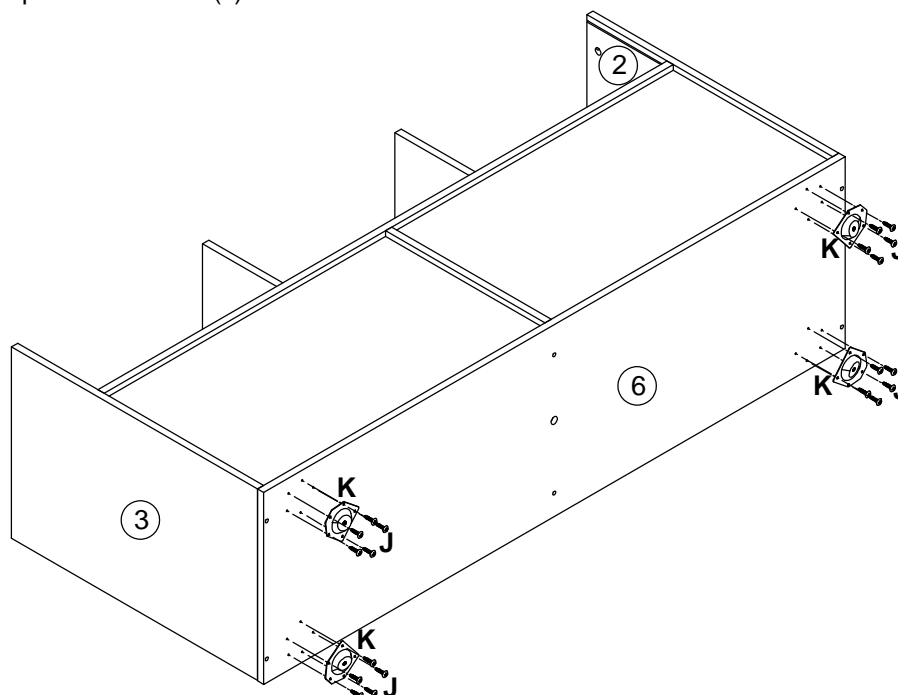

Step 8

Attach legs parts 12 to the part K and tighten .
Then fix leg 13 to part 6 using screw(L)
as shown.

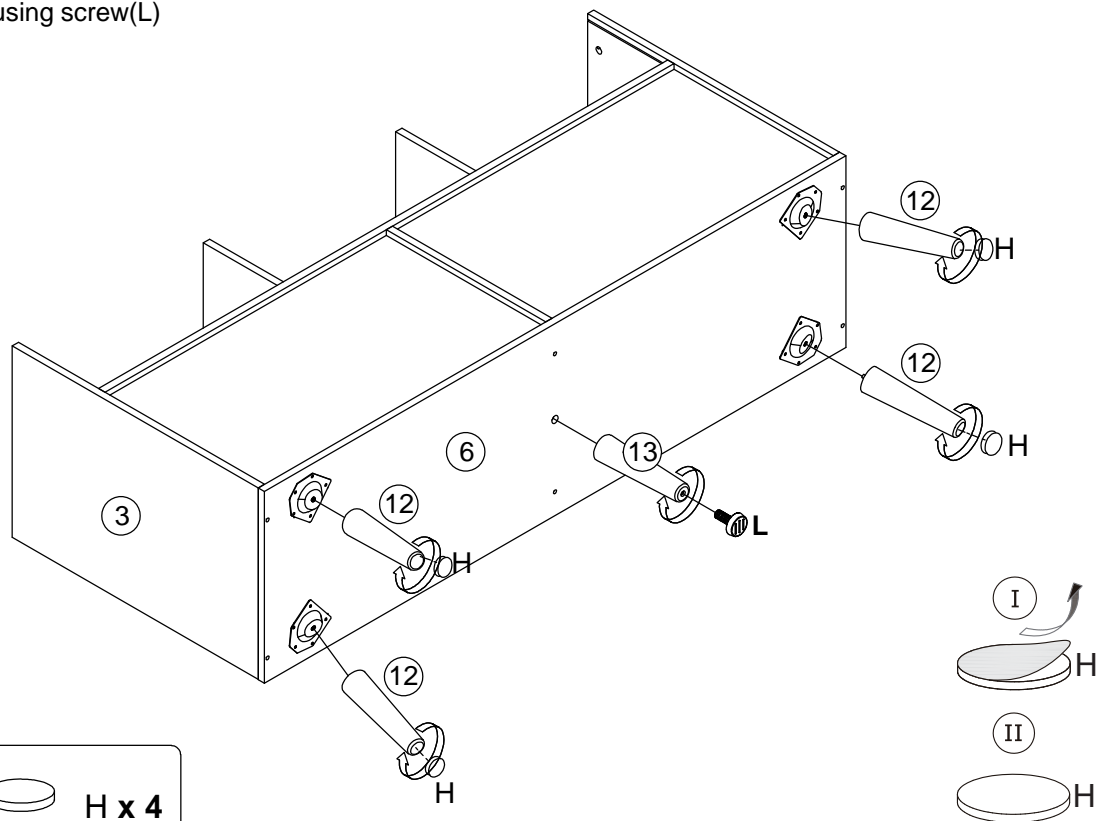

Step 9

Insert quickfit screws(A) into corresponding holes in part 1 as shown.

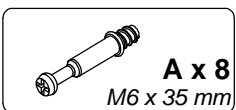
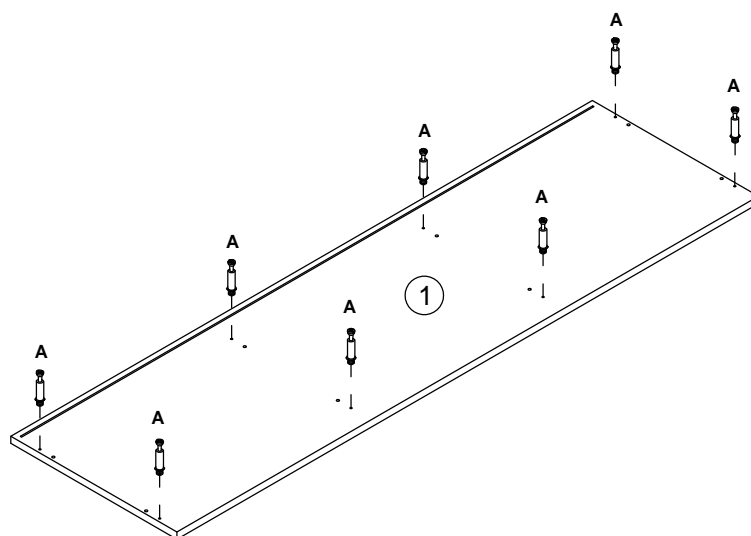

Step 10

Insert wooden dowels (C) into part 1, as shown.
Add cam locks (B) into assembled unit as shown
and attach part 1 to assembled unit.
Turn cam locks clockwise to tighten.

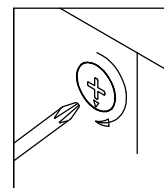
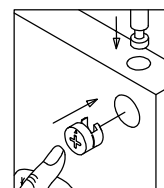
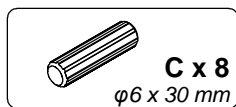
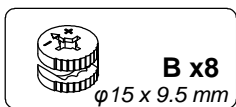
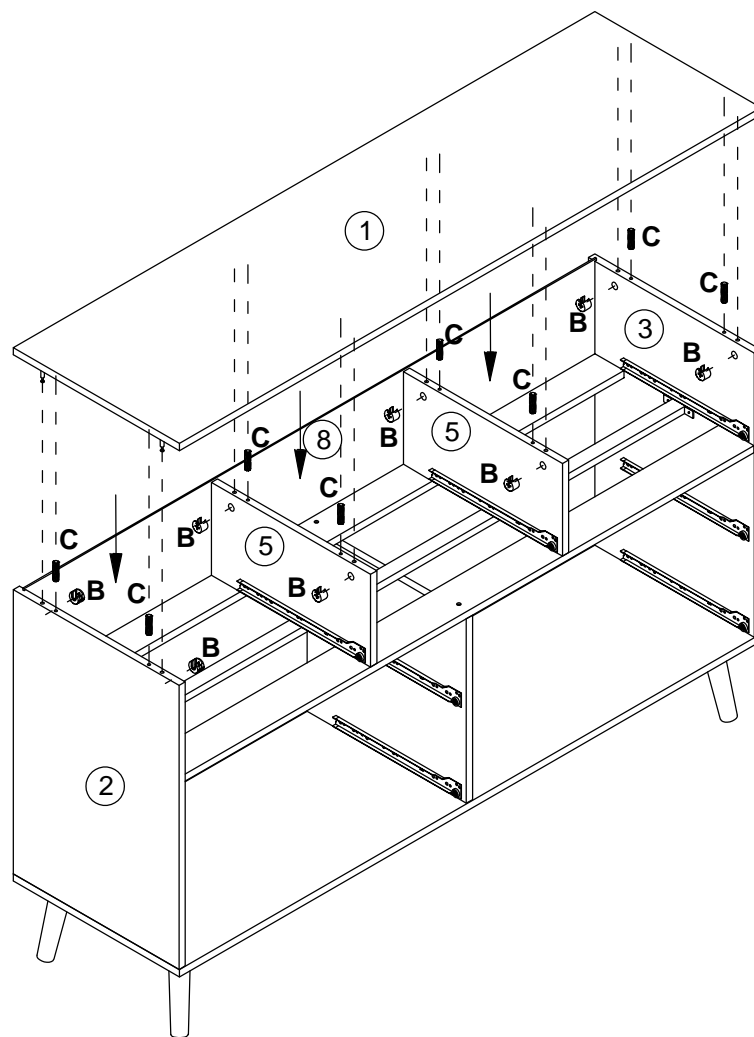

Step 11

Insert quickfit screws(A) into corresponding holes in parts 14 and 19 as shown.

Fix handle (F) to part 14 and 19 using bolts(E), as shown. Do not use an electric screwdriver, do not use force during the rotation of the accessories, otherwise it may cause the board to crack

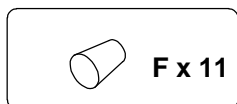
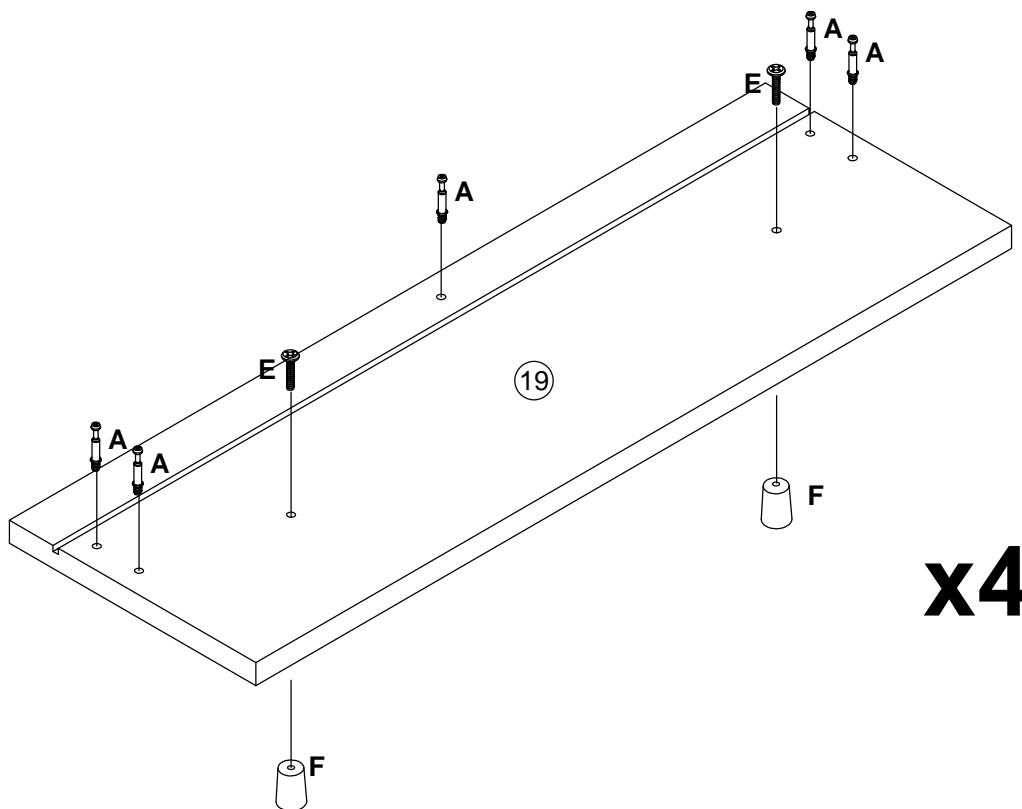
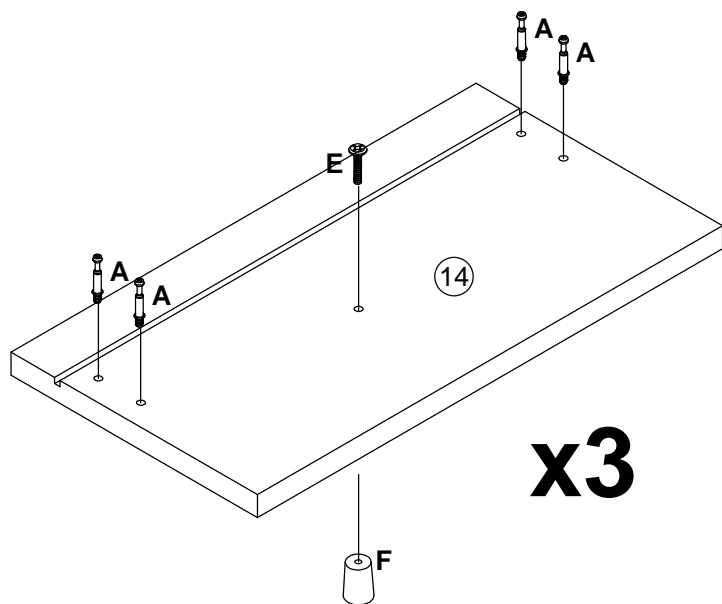

Step 12

Attach parts 15 and 16 to part 17 using screws(D), as shown.

Attach parts 15 and 16 and 21 to part 20 using screws(D), as shown.

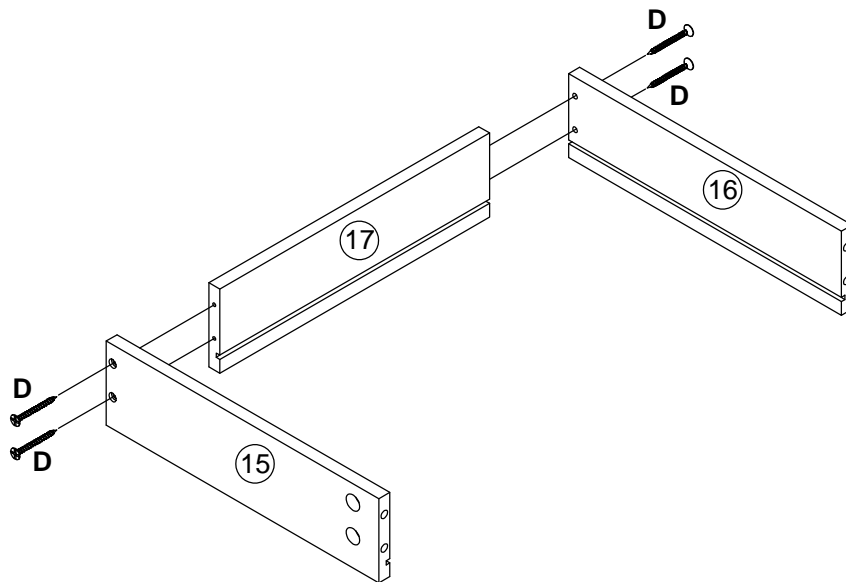

x3

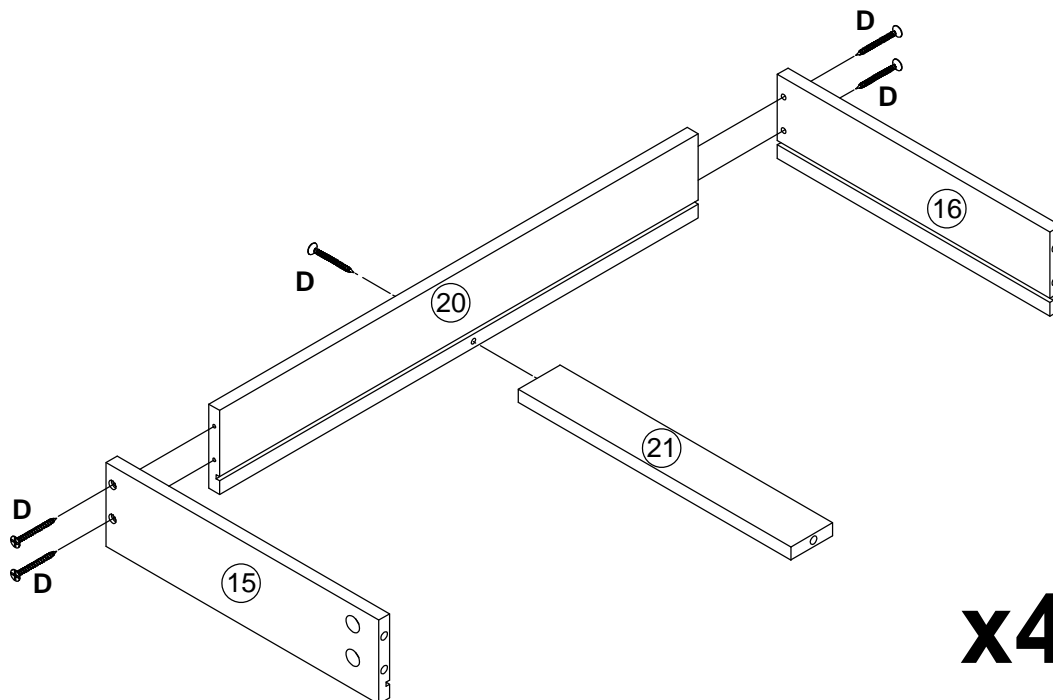

x4

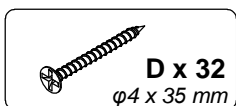

Step 13

Slide part 18 into available slots of parts 15 and 16,as shown.

Slide part 22 into available slots of parts 15 and 16,as shown.

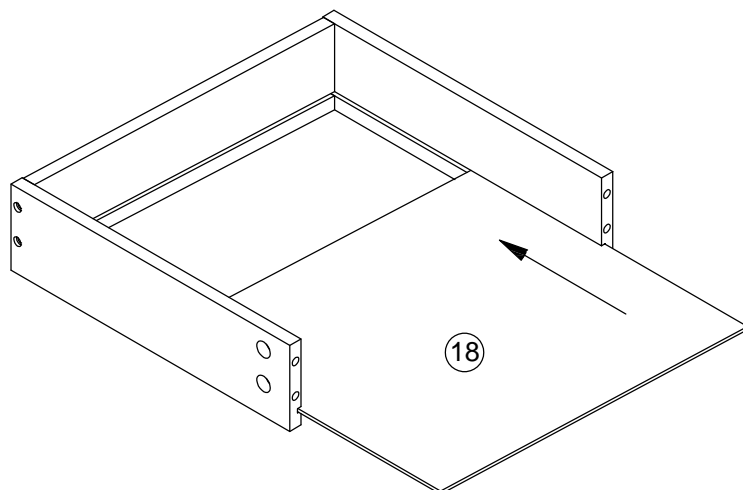

x3

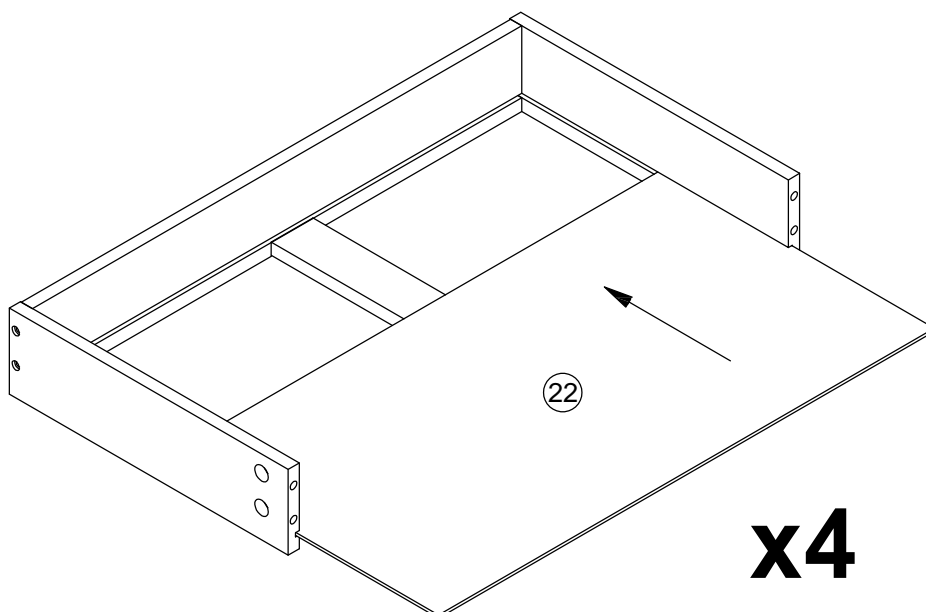

x4

Step 14

Insert cam locks(B) to parts 15 and 16 and attach part 14 and 19 as shown.
Turn cam locks clockwise to tighten.

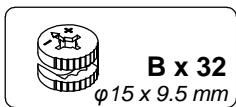
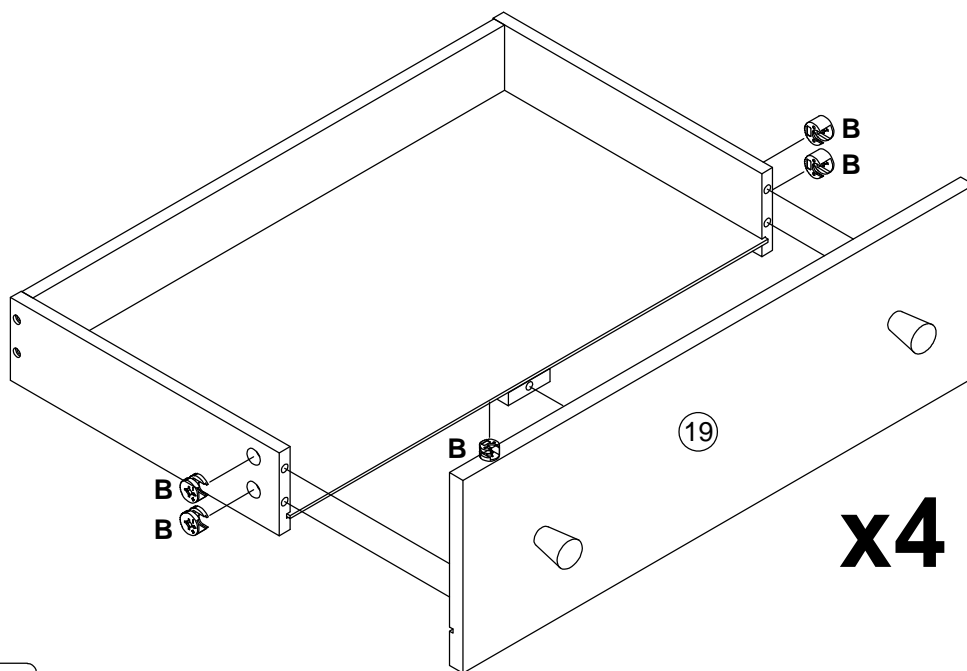
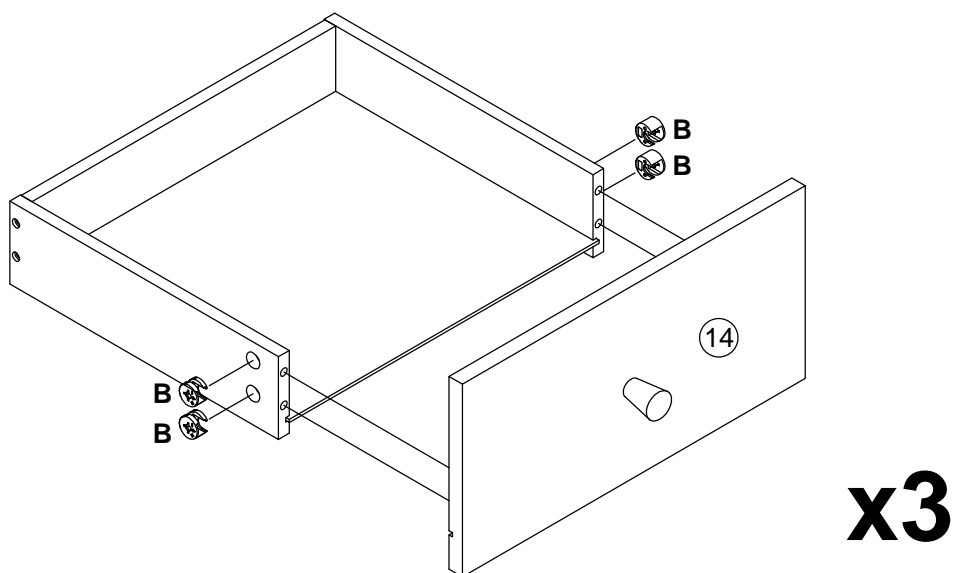

Step 15

Fix left inner drawer runner (DL) to part 15 and fix right inner drawer runner (DR) to part 16 using screws (I), as shown.

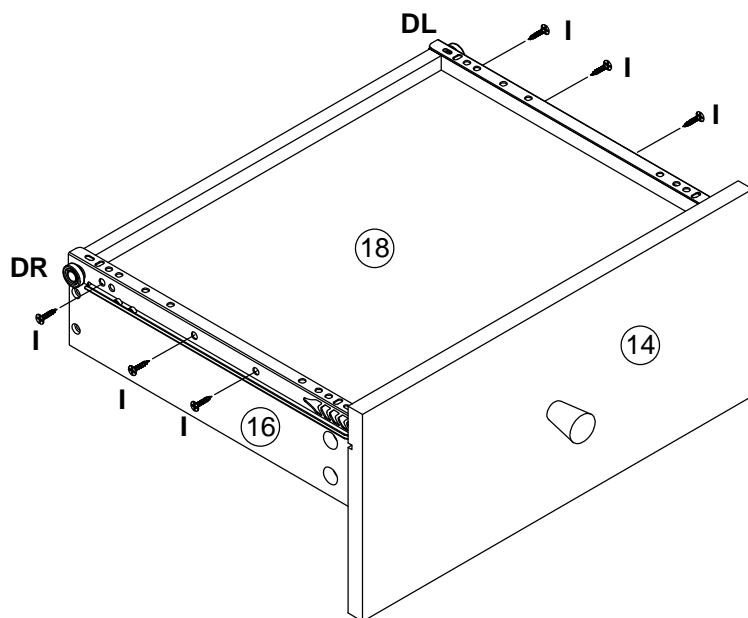

x3

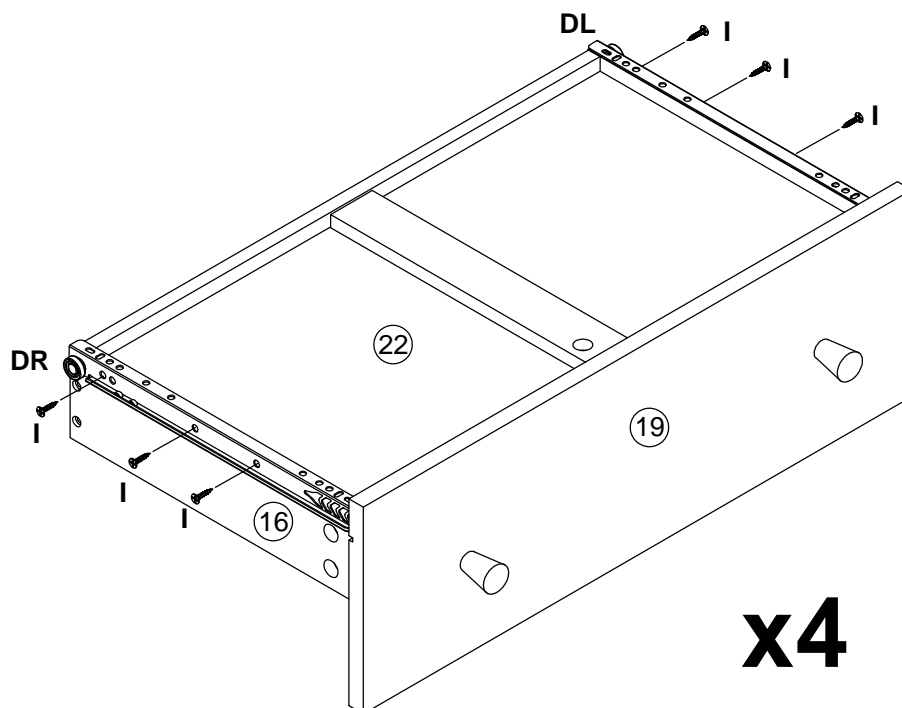

x4

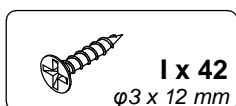

Step 16

The drawer slides must be aligned with the internal rails, otherwise the drawer will tilt.

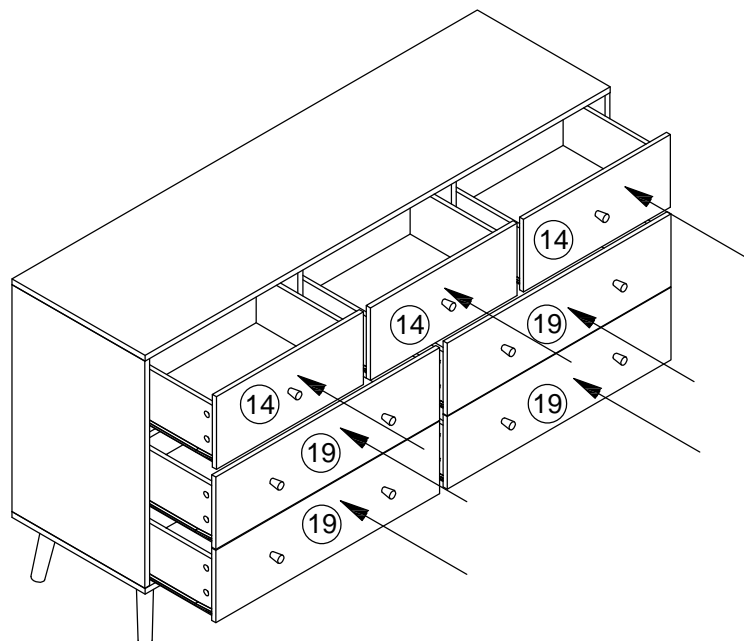

Step 17

Attach wedges (M) as shown using screws.

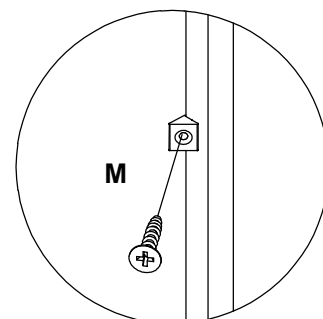
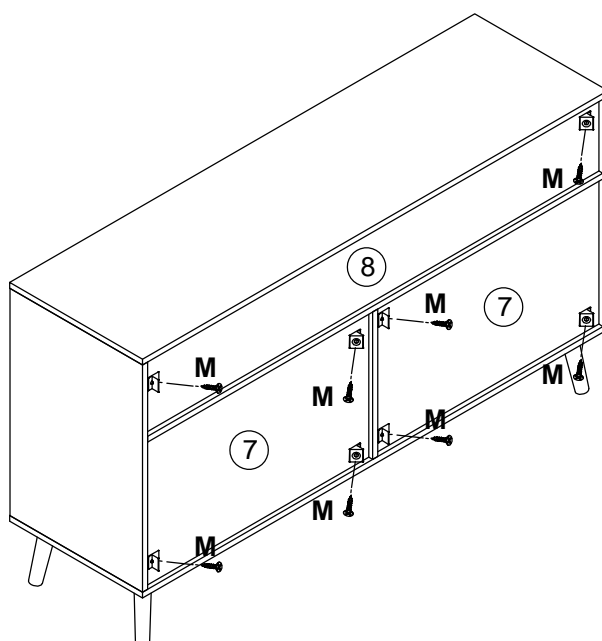

Step 18

Install anti-tipping device as shown.

