

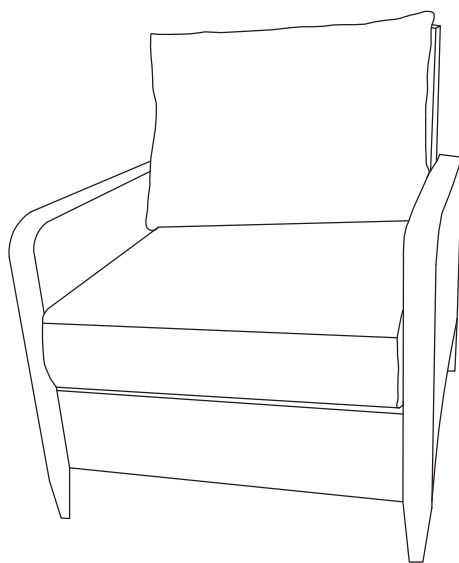







Outdoor Wicker Arm Chair

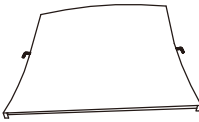
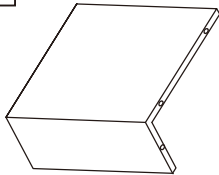
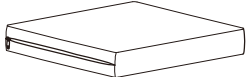

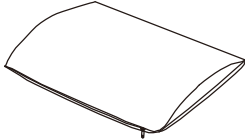
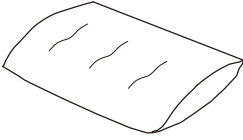
PART LIST

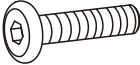
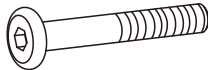
A 	B 	C 	D 	E 
Left Arm Panel 1 PC	Right Arm Panel 1 PC	Back Panel 1 PC	Seat Panel 1 PC	Seat Cushion Cover * 1 PC
F 	M 	N 	*Please note cushion covers will ship separately.	
Seat Cushion Core 1 PC	Back Cushion Cover * 1 PC	Back Cushion Core 1 PC		

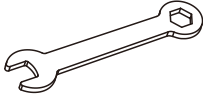



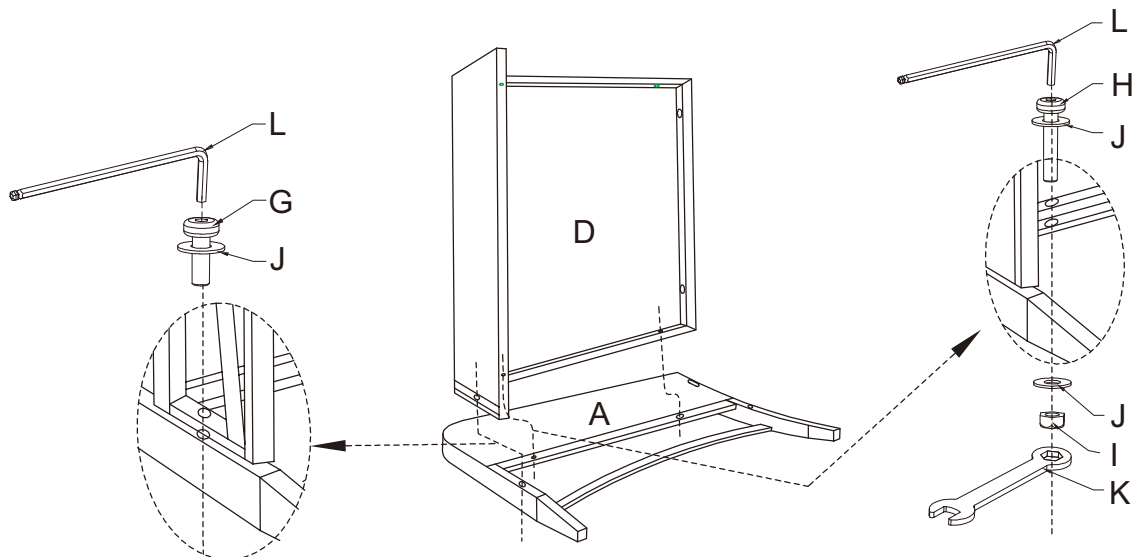

HARDWARE LIST

G 	H 	I 	J 	K 
M6*40mm Short Bolt 6 PCS (Extra 2)	M6*50mm Long Bolt 4 PCS (Extra 1)	M6mm Hex Nut 4 PCS (Extra 1)	M6mm Flat Washer 14 PCS (Extra 3)	M6mm Wrench 1 PC
L 				
M6mm Allen Wrench 1 PC				

Step 1. Lay left arm panel (part A) down on a soft flat surface, such as carpet. Attach seat panel (part D) to left arm panel (part A) using short bolt (part G), long bolts (part H), flat washers (part J), hex nuts (part I), wrench (part K) and allen wrench (part L).

NOTE: Please do not fully tighten bolts until unit is fully assembled.



G		x1
H		x2
I		x2
J		x5
K		x1
L		x1

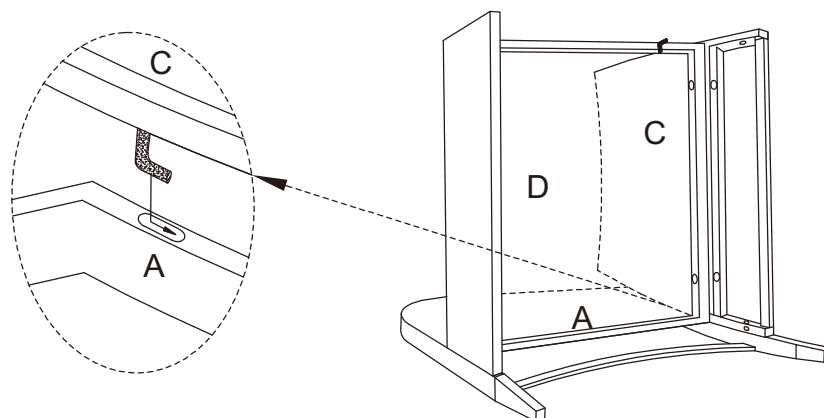

Step 2. Attach back panel (part C) to left arm panel (part A) by inserting the hook into the hole.

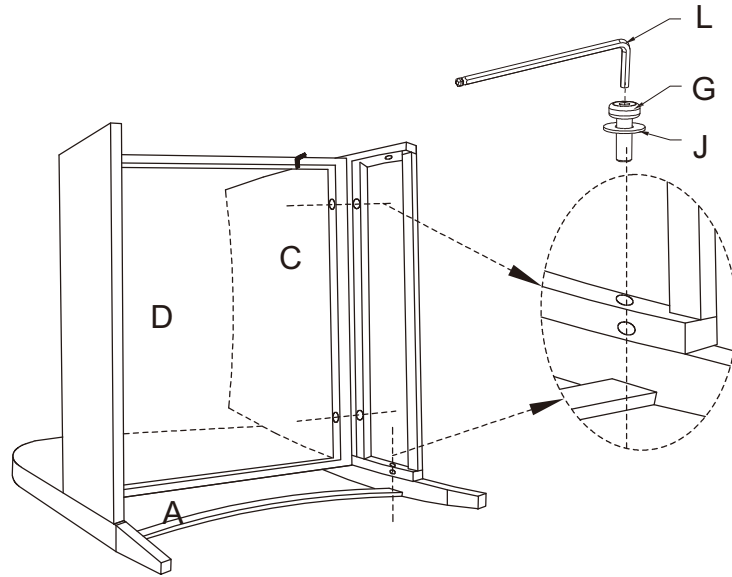

Step 3. Attach back panel (part C) to assembled unit (parts A & D) using short bolts (part G), flat washers (part J) and allen wrench (part L).

NOTE: Please do not fully tighten bolts until unit is fully assembled.



G		x3
J		x3
L		x1

Step 4. Attach right arm panel (part B) to back panel (part C) by inserting the hook into the hole.

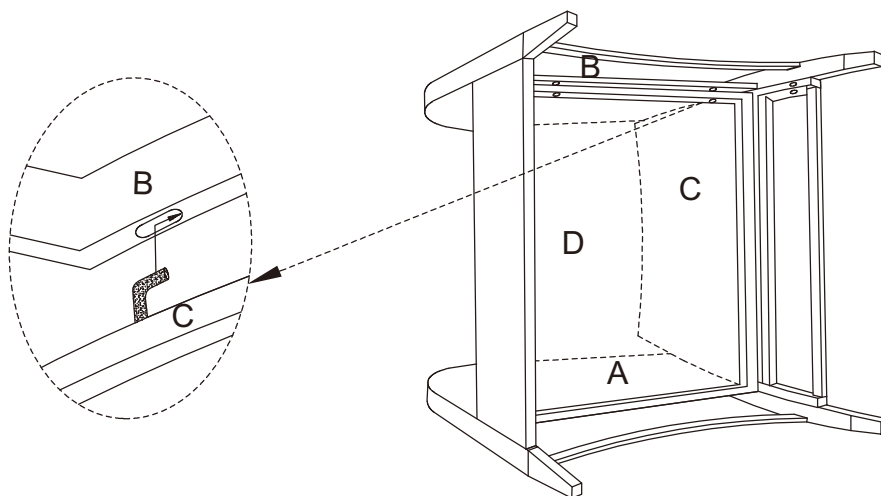

Step 5. Attach right arm panel (part B) to assembled unit (parts C & D) using short bolts (part G), long bolts (part H), flat washers (part J), hex nuts (part I), wrench (part K) and allen wrench (part L).

NOTE: Please fully tighten all bolts at this time.

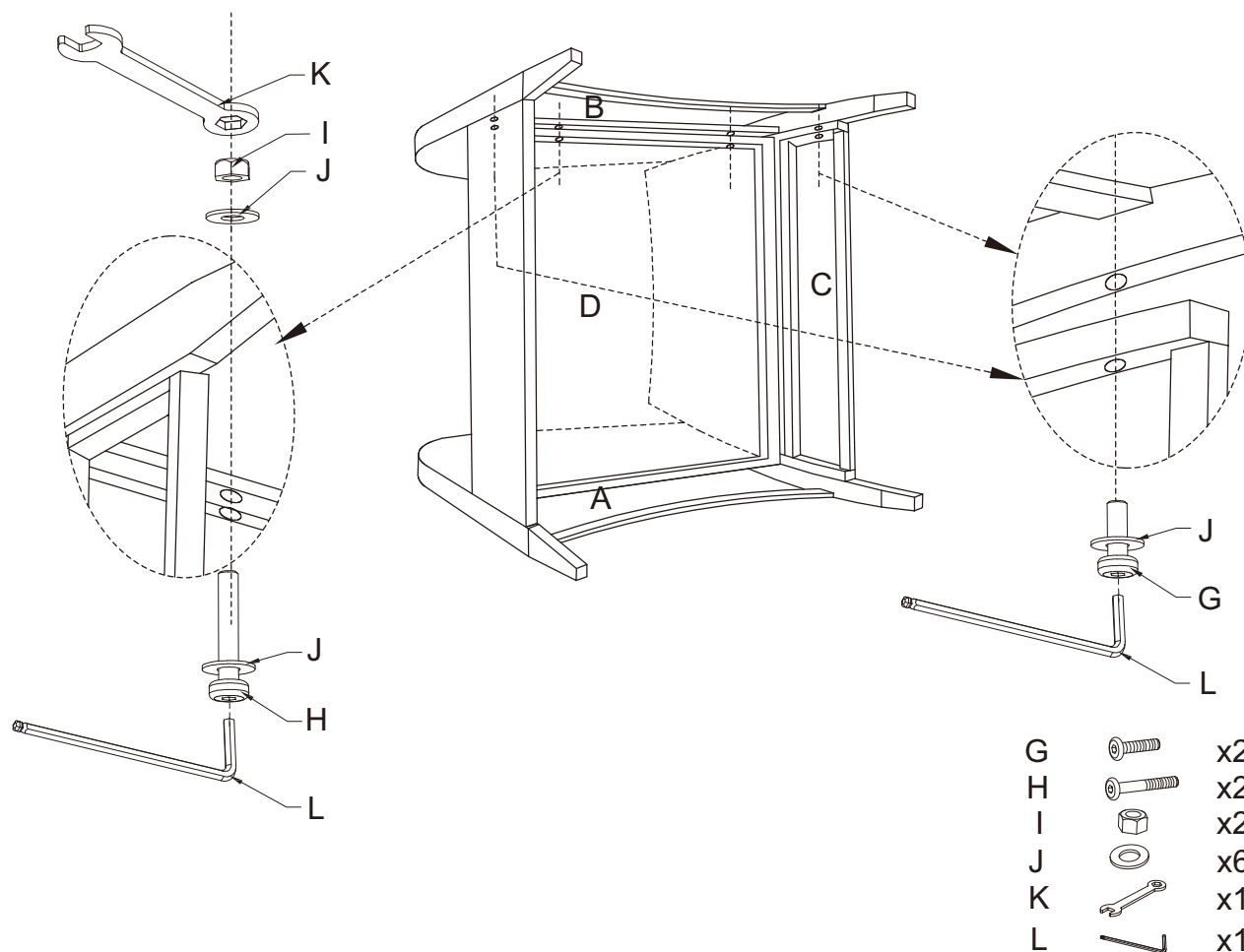

Step 6. Insert seat cushion core (part F) into seat cushion cover (part E).

Insert back cushion core (part N) into back cushion cover (part M).

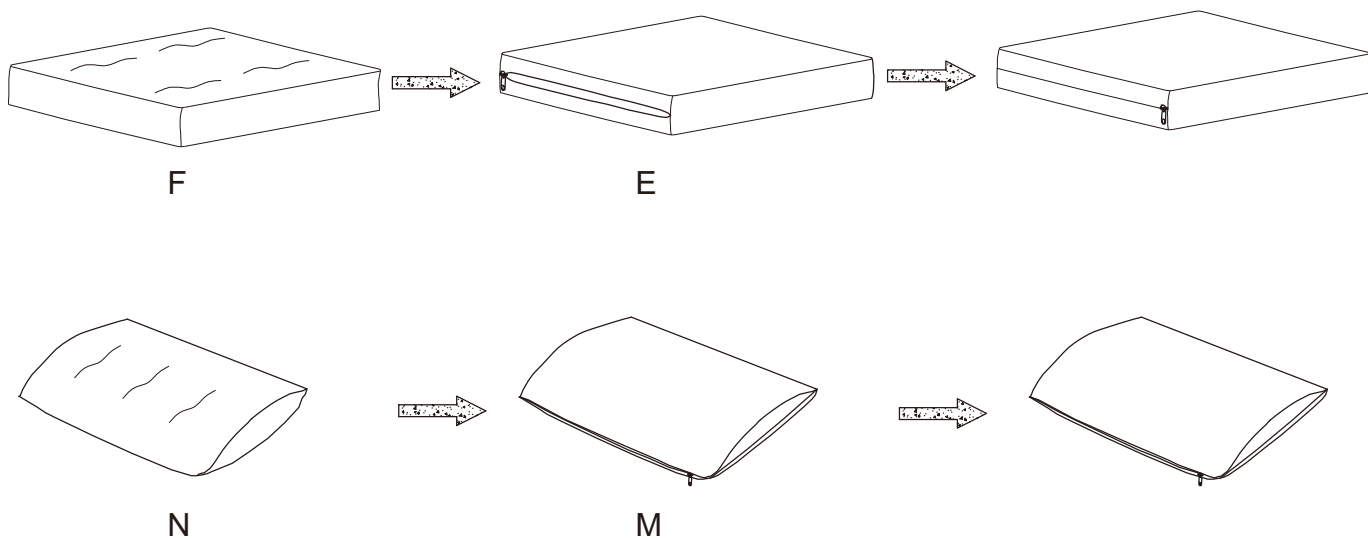

Step 7. Place seat cushion and back cushion as shown below.

