

# Wood Surfaces

Installation instructions

## Included Parts

- (1) Pins Neck
- (1) Pins Base
- (2) Wood Lags
- (1) Hex Key
- (2) Nuts
- (1) 8.5"x11" Plotting Guide

## Required Tools

- (1) Level
- (1) Drill
- (1) 5/32" (4mm) Drill Bit
- (2) 10mm or adjustable wrenches
- (1) M6 Driver (recommended)

**Important Note:** These installation instructions are only for attaching Pins to solid wood or plywood surface with a minimum thickness of 1/2" (12.7mm). Please reference Pins for Drywall (SKUs: VPC-) for drywall information.



## 1. MARK MOUNTING HOLE LOCATIONS

Use a level to ensure the printed mounting template is horizontal along the long edge (Figure A), mark hole locations by piercing the template with a pencil or sharp object at the center the two (2) marks corresponding with the bottle direction chosen. Mounting holes will be 5 1/2" (144mm) apart and offset by 5/8" (16mm).

*Pro Tip:* To plot additional Pins in the same column, mark a minimum of 5" (127mm) above or below each mounting hole for next set of Pins.

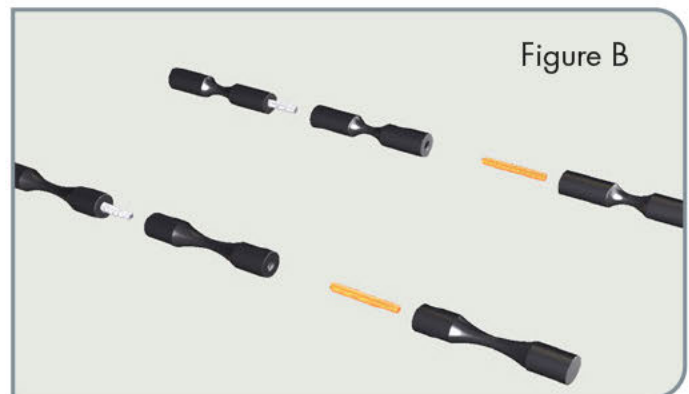

## 2. (OPTIONAL) EXTEND PINS

If using Pins extensions (sold separately), thread a stud into one end of the base extension Pin and screw the starter base Pin onto the remaining exposed end and firmly hand tighten (Figure B).

Connect any additional extensions (up to three total bottles deep for 750ml bottles; up to two bottles deep for magnum configurations with Pins Magnum Spacer) in a similar fashion and repeat this process for the neck pins.

## Instructions: Pins for Wood Surfaces

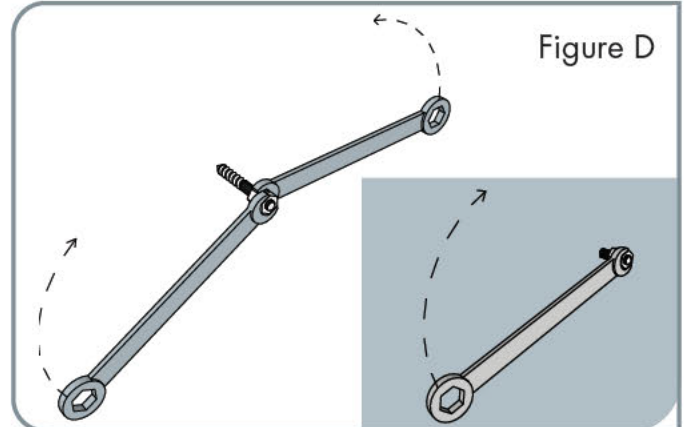
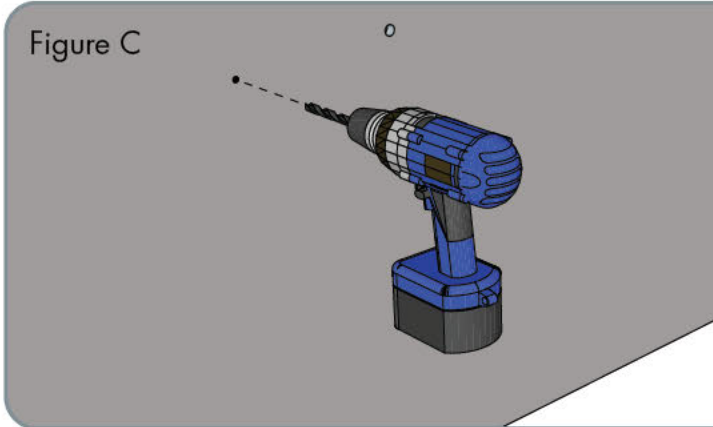

### 3. CONFIRM WALL SURFACE

Drill two (2) pilot holes using a 5/32" (4mm) Drill Bit (Figure C) to determine whether your installation will be into solid wood or drywall surface.

*NOTE: If it is determined to be drywall, please use (or purchase if necessary) Series Collars and reference the Pins with Collars (SKUs: VPC-) install guide.*

### 4. INSTALL WOOD LAGS

#### a. Using Hex Key or M6 Driver

Using either the provided hex key, drive the Lag Stud into the pilot holes until the coarse threads are no longer visible. When driving the Lag Stud, take care to ensure it remains level.

For larger projects or if a sturdier tool is needed, use an optional M6 Driver.

#### b. Using Nuts

Alternatively, attach two (2) provided nuts onto the fine threaded end of the Lag Stud. Using two 10mm wrenches, tighten the nuts against one another (Figure D), essentially creating a screw head. Then use one wrench on the outer nut and screw the wood lag into the pilot holes until the coarse threads are no longer visible.

### 4. INSTALL PINS

Thread two (2) Pins onto the Studs (Figure E). Then, firmly hand-tighten taking care not to over tighten. Confirm Pins are level.

Ensure you are installing the Neck Pin into the higher of

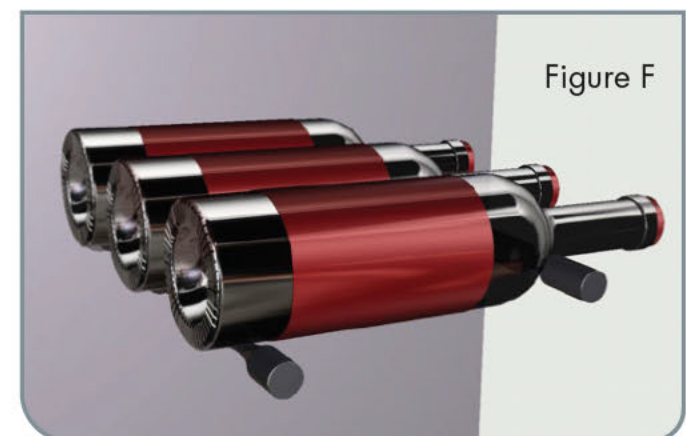
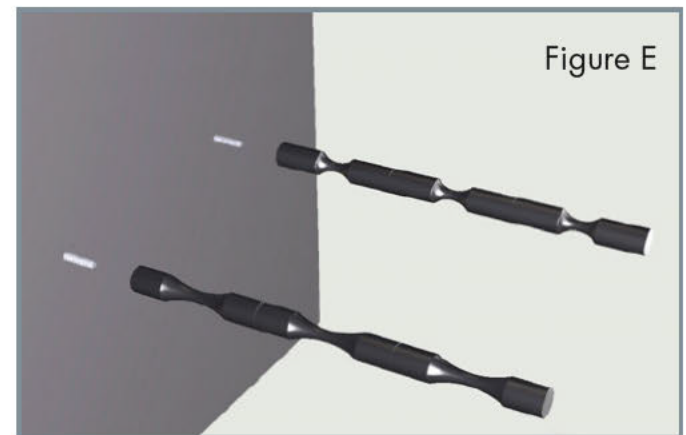

the two holes and the Base Pin into the lower of the two holes.

### 5. ADD WINE

Only the good stuff.

## Instructions: Pins for Wood Surfaces (VP)

### **Additional Notes:**

All installations into drywall require the use of collars and alternate fasteners to properly support the Pins. Any application outside of these parameters is not warranted by and may result in product and/or installation failure, property damage and/or bodily injury.

### **Maintenance and Care:**

Pins should be regularly checked for tightness. Should any party to be

found to be loose, tighten by hand until secure. If the face of the wall surface shows signs of breakage, discontinue use immediately until the wall may be adequately repaired. Pins may be cleaned with a damp cloth and mild dish soap -abrasive pads or steel wool should NOT be used as they will damage the finished surfaces of the parts.