



OWNER'S MANUAL

AIR PURIFIER

Read this owner's manual thoroughly before operating the appliance and keep it handy for reference at all times.

ENGLISH

TABLE OF CONTENTS

3 IMPORTANT SAFETY INSTRUCTIONS

- 3 READ AND SAVE THESE INSTRUCTIONS
- 3 WARNING INSTRUCTIONS
- 6 CAUTION INSTRUCTIONS

8 OPERATION

- 8 Product Overview
- 10 Preparation before Operation
- 12 Features
- 14 Operating the Air Purifier
- 15 Using the Extra Functions
- 17 Overall Air Quality

18 SMART FUNCTIONS

- 18 LG ThinQ Application
- 20 Smart Diagnosis

21 MAINTENANCE

- 21 Maintaining the Product

25 TROUBLESHOOTING

- 25 Before Calling for Service

27 APPENDIX

- 27 Information

28 LIMITED WARRANTY

- 28 USA

IMPORTANT SAFETY INSTRUCTIONS

READ AND SAVE THESE INSTRUCTIONS

The following safety guidelines are intended to prevent unforeseen risks or damage from unsafe or incorrect operation of the appliance.

The guidelines are separated into 'WARNING' and 'CAUTION' as described below.

Safety Messages

Your safety and the safety of others are very important.

We have provided many important safety messages in this manual and on your appliance. Always read and follow all safety messages.



This is the safety alert symbol.

This symbol alerts you to potential hazards that can kill or injure you and others. All safety messages will follow the safety alert symbol and either the word WARNING or CAUTION.

These words mean:



WARNING

You may be killed or seriously injured if you do not follow instructions.



CAUTION

You may be injured or cause damage to the product if you do not follow instructions.

All safety messages will tell you what the potential hazard is, tell you how to reduce the chance of injury, and tell you what may happen if the instructions are not followed.

WARNING INSTRUCTIONS

WARNING

- To reduce the risk of explosion, fire, death, electric shock, injury or scalding to persons when using this product, follow basic precautions, including the following:

Technical Safety

- This appliance is not intended for use by persons (including children) with reduced physical, sensory or mental capabilities or lack of experience and knowledge, unless they have been given supervision or instruction concerning use of the appliance by a person responsible for their safety. Children should be supervised to ensure that they do not play with the appliance.
- The fan is not a toy. It should not be played with or placed where young children can reach it.
- If the supply cord is damaged, it must be replaced by the manufacturer, its service agent or similarly qualified person in order to avoid a hazard.
- Only an authorized repair person should disassemble, repair, or modify the appliance.
- Do not touch the power plug with wet hands.
- Do not install and use broken parts.
- Do not continue to use the product if it is visibly damaged.
- The appliance is only to be used with the power supply unit provided with the appliance.
 - Failure to use the supplied power supply may result in reduced performance or failure of the product, and may result in safety hazards.

4 IMPORTANT SAFETY INSTRUCTIONS

- The appliance must only be supplied at safety extra low voltage corresponding to the marking on the appliance.
- Be careful not to subject the power plug and adapter to shock.
- Do not use the product if it has been dropped on the floor.
- To reduce The Risk Of Fire, Electric Shock Or Injury To Persons, Do Not Use Replacement Parts That Have Not Been Recommended By The Manufacturer (e.g. Parts Made At Home Using A 3D Printer).
- To Reduce The Risk Of Fire Or Electric Shock, Do Not Use This Fan With Any Solid-State Speed Control Device.
- RISK OF ELECTRIC SHOCK - These servicing instructions are for use by qualified personnel only. To reduce the risk of electric shock, do not perform any servicing other than that contained in the operating instructions unless you are qualified to do so.
- This manual is also available in a PDF format at www.lg.com and you can obtain a printed copy of the manual from the PDF format.

Installation

- Do not install the appliance on an uneven or inclined surface.
- Do not install the appliance in an area exposed to direct sunlight or near heat-generating equipment.
- Do not install the product in a place where combustible gas may leak or industrial oil or metallic particulates are present.
- Do not allow the appliance to push against the power cord or plug.
- Do not bend the power cable excessively or place a heavy object on top of it.
- Do not extend the length of the power cable or alter it.
- Do not use several devices on a multi-socket extension outlet.
- Make the connection securely so that screw-in terminals will not be loosened when the cable is pulled.
- Make sure that the power cable cannot be pulled out or damaged during operation.
- When unplugging the power cord, always pull it by the plug.
- Unplug the appliance during thunder or lightning storms or when not in use for a long time.
- This appliance has a polarized plug (one blade is wider than the other).
 - To reduce the risk of electric shock, this plug is intended to fit in a polarized outlet only one way.
 - If the plug does not fit fully in the outlet, reverse the plug. If it still does not fit, contact a qualified electrician.
 - Do not attempt to defeat this safety feature.
- Do not run cord under carpeting. Do not cover cord with throw rugs, runners, or similar coverings.
- Do not route cord under furniture or appliances. Arrange cord away from traffic area and where it will not be tripped over.

Operation

- If the appliance is immersed in water, stop using it and contact an LG Electronics Customer Information Center.
- Do not operate any fan with a damaged cord or plug. Discard fan or return to an authorized service facility for examination or repair.
- If there is a gas leakage (isobutane, propane, LNG, etc.), do not touch the appliance or power plug and ventilate the area immediately.
- If you detect any abnormal noise, odor or smoke, unplug the appliance immediately and contact an LG Electronics Customer Information Center.

- Do not use or store fire, combustibles (ether, benzene, alcohol, drugs, propane, butane, combustible sprays, insecticide, air freshener, cosmetics, etc.) or flammable materials (candles, lamps, etc.) near the product.
- Do not allow animals or pets to chew on the power cord.
- Do not move the appliance when it is in operation.
- Do not hit the appliance.
- Do not insert hands or metal objects into the air inlet or outlet.
- Do not put flammables into the appliance.
- Do not move or operate the appliance while its cover is open.
- Do not allow children to climb on or play with the appliance.
- Do not place anything on top of the appliance.
- User Servicing Instructions.
 - Only an authorized repair person from an LG Electronics service center should disassemble, repair, or modify the product.

Maintenance

- Dispose of the packing materials (vinyl, styrofoam, etc.) to keep them out of the reach of children.
- Take care not to injure or pinch yourself when you detach and reattach parts of the appliance.
- Turn off and unplug the appliance before cleaning it or replacing the filter.
- Do not clean the appliance with brushes, cloths or sponges which are abrasive or made of metal.
- For inner cleaning, contact an Authorized Service Center or a dealer.
- Do not use harsh detergent that can cause corrosion or damage to the unit.
- Harsh detergent may also cause failure of product, fire, or electric shock.

CAUTION INSTRUCTIONS

CAUTION

- To reduce the risk of minor injury to persons, malfunction, or damage to the product or property when using this product, follow basic precautions, including the following:
-

Installation

- Do not tilt the appliance to pull or push it when transporting.
- Do not install the appliance in a vehicle, RV, or marine vessel.
- Do not place the appliance near a TV or stereo equipment.
- Do not place the appliance under bright light.
- The appliance must be installed in accordance with national wiring regulations.
- When moving or storing the appliance, wrap the power cord around the base of the appliance to prevent personal injury, damage to the cord or damage to floors.
- Do not place the appliance near curtains.
- Insert the adapter all the way into the adapter connection terminal, and avoid moving it while connected.

Operation

- Do not use the product for removal of toxic gas such as carbon monoxide.
- Do not use the product for ventilation purposes.
- Do not use the appliance for a long time in a region with unstable voltage.
- Do not place obstacles around the air inlet or outlet.
- For safe use of the appliance, children or others with reduced mental capabilities need to be closely monitored by a person who is responsible for their safety.
- Do not use the product for special purposes such as preserving plants, precision instruments, artworks, etc.
- Do not operate the appliance with wet hands.
- Do not let the moisture from a humidifier directly touch the appliance.
- Do not use the appliance while it is not in an upright position.
- Do not use the appliance near objects vulnerable to heat.
- Do not use detergents, cosmetics, chemicals, air fresheners, or disinfectants in the appliance.
- Do not touch any internal parts while the unit is operating or immediately after operation.
- Use the filter only for its intended purpose.
- The Deodorization filter and Dust Collection filter are assembled together. Do not try to detach them from each other.
- Do not insert any objects into the air outlet.

Maintenance

- Do not use strong detergents or solvents to clean the appliance. Use a soft cloth to clean.
- Do not clean the appliance with an alkaline detergent.
- Do not wipe the appliance surface using sulfuric acid, hydrochloric acid or organic solvents (thinner, kerosene etc.) or attach a sticker on the appliance.

-
- Do not allow water inside the appliance.
 - Do not wash the filter with water.
 - Be careful not to damage the ultra-fine filter when cleaning it with a vacuum cleaner.

SAVE THESE INSTRUCTIONS

OPERATION

The exterior or components of the product may vary depending on the model.

Product Overview

Air Purifier

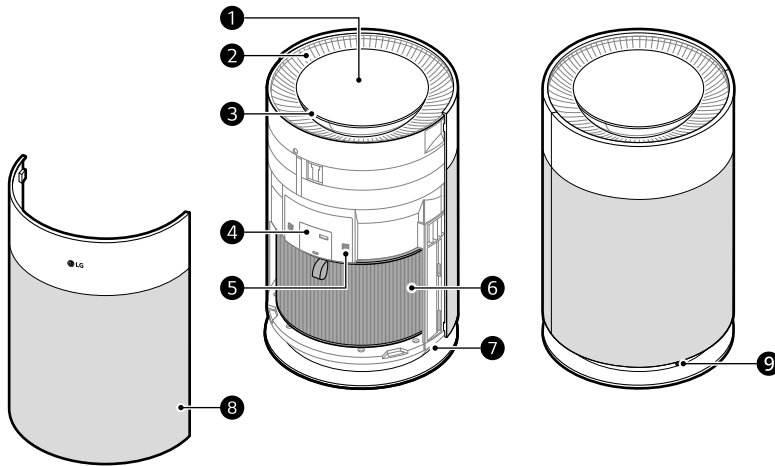

1 Control Panel/Status Panel

- Use it to set the appliance functions.
- Use it to check the settings of the appliance and the air quality.

2 Air Outlet

- Emits air purified by the filter.

3 Air Quality Light

- Indicates the current air quality by color.

4 PM1.0 Sensor

- Detects the concentration of particulate matter (PM).

5 Odor (Gas) Sensor

- Detects odors (gases).

6 Filter

- Eliminates fine particulates, smog-causing materials, other odors.

7 Handle

- Use it to carry and move the product.

8 Air Inlet (Cover)

- Air is sucked into the air purifier through the air inlet.
- Front and rear covers can be disassembled separately.

9 Adapter Connection Terminal

- The adapter can be removed.

Filter

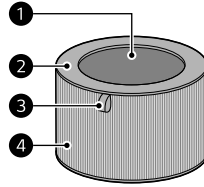

1 Deodorization Filter

- This filter removes smog-causing substances (SO₂, NO₂) and household odors (toluene, formaldehyde).

2 Dust Collection Filter

- Minimizes PM1.0 from the air.

3 Filter Handle

- Used to remove or install the filter.
- The side with the handle should face upwards.

4 Pre-Filter

- The pre-filter is attached to the exterior of the filter and primarily removes household dust with large particles from the air.

⚠ CAUTION

- Do not forcefully separate the filters, as the filters are attached.
- Do not throw the filters or use them for other purposes.

Components

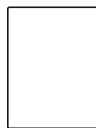

1

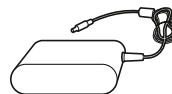

2

1 Owner's Manual

2 Adapter

Preparation before Operation

Removing the Protective Vinyl from the Filter

Unpack the appliance and remove all packing tape and filter packaging before using the appliance.

- 1 Take the product out of the box, and remove the film and packing tape attached to the product.
- 2 Hold the top of the front cover with the **LG** logo on it. Pull the cover forward to remove it.

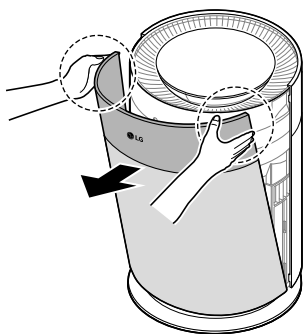

- 3 Remove the filter and dispose of the packaging.

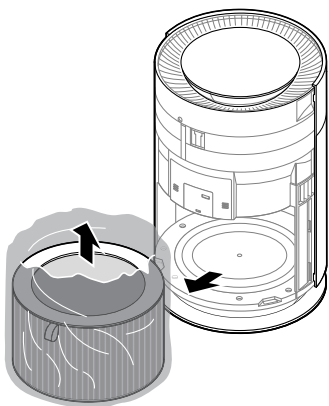

- 4 Install the filter in the product.
 - Make sure that the side with the filter handle (1) is facing up.

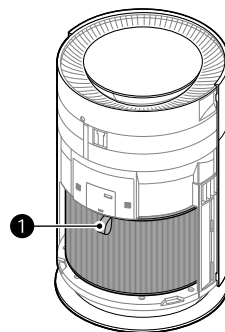

- 5 To reinstall the cover, fit the tabs at the bottom of the cover into the groove around the base of the product and then close the cover.

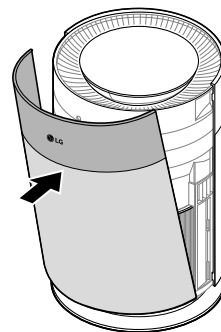
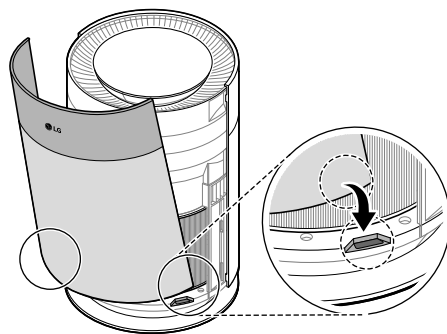

⚠ CAUTION

- Be sure to remove the protective vinyl from the filter before using the product.
- Install the filter with the handle at the top. Failure to do so may cause product malfunction and failure.

Installation Location Requirements

Install the product at least 3 1/4 ft (1 m) from walls.

- If there is not enough room for air suction, the air purification performance may be affected.

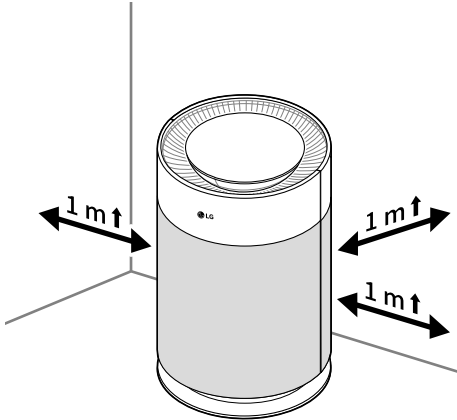

- The performance of the product may differ depending on the operating environment (considering factors such as temperature and humidity).
 - The product's guaranteed performance standards can be achieved at humidity levels of 40 % to 70 %.
- Do not install the product near direct sunlight or bright lighting.
 - Doing so may cause discoloration of the product.

Transportation Requirements

- Before moving or storing the product, wrap the cord around the lower part of the product to keep the power plug from touching the floor.
 - Failure to do so may damage the power plug or scratch the floor.
- Carry the product safely by using the handle (❶) at the bottom of the product with both hands.

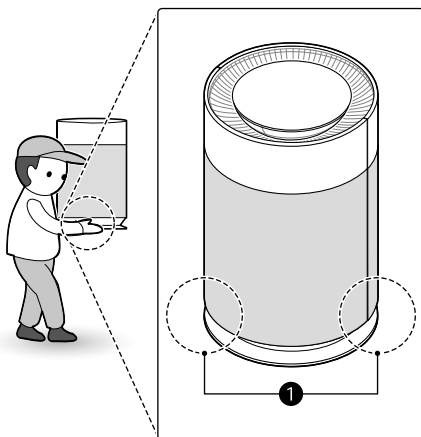

⚠ CAUTION

- Do not carry the product by holding the external cover.
 - Doing so may allow the cover to open and the product to drop. Dropping the appliance may cause personal injury or product malfunction.

Connecting the Power

- 1 Connect the adapter to the adapter connection terminal on the back of the product.

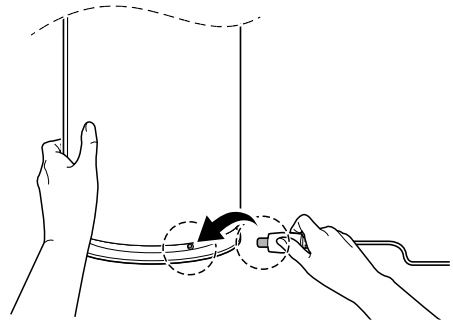

- 2 Plug the power plug of the adapter into an outlet.

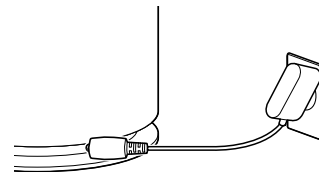

NOTE

- Hold the product and connect or disconnect the adapter horizontally.
- Connect the adapter to the end of the adapter connection terminal, and do not move it after it is connected. (Doing so may result in damage.)
- Be careful not to apply impact to the adapter. Doing so may result in damage.

Features

Controlling the Air Purifier

Control Panel

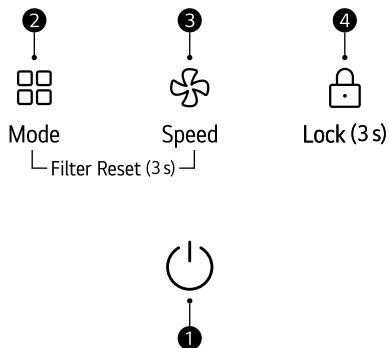

1 Start/Stop Button

Turns the product on or off.

- To prepare the product to connect to Wi-Fi through the **LG ThinQ** application, press and hold the button for 3 seconds or more.

2 Mode Button

Sets the mode.

3 Speed Button

Adjusts the fan speed of the air purifier.

4 Lock Button

Lock or unlock the control panel buttons, press and hold the button for 3 seconds or more.

NOTE

- Use additional functions by pressing the buttons on the control panel for 3 seconds.

Long press (more than 3 seconds)	Extra Functions
	Filter Status Notification Reset
	Smart Diagnosis

Status Panel

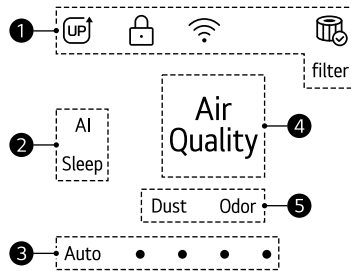

1 Add-on Display

Icon	Description
	Lights up when there are new features that can be upgraded.
	Lights up when the lock function is set.
	Lights up when the Wi-Fi function is activated.
	The color indicates the life of the filter. For detailed information, refer to Replacing the Filters .

2 Display Operating Mode

Indicates the current operating mode.

3 Fan Speed Display

Displays the air purifier's fan speed.

Speed	Display	Description
Auto	Auto ●●●●	Number of indicator lights changes according to the overall air quality.
Low	●	1 LED ON
Medium	●●	2 LEDs ON
High	●●●	3 LEDs ON
Turbo	●●●●	4 LEDs ON

4 Overall Air Quality (Color)

The overall air quality is indicated by color. → See **Overall Air Quality** for detailed color information.

5 Indication of Dust/Odor

Dust: This indication is displayed when the level of dust concentration is higher than the level of odor concentration.

Odor: This indication is displayed when the level of odor concentration is higher than the level of dust concentration.

- These indications are displayed at the same time when the level of dust concentration is the same as the level of odor concentration.

Operating the Air Purifier

Start/Stop

Press the **Start/Stop** button to turn the air purifier on or off.

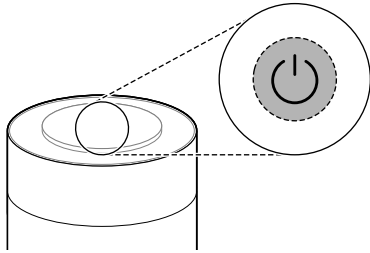

NOTE

- When it is turned on for the first time, the appliance operates in **Purify** mode.
- The most recently used mode is saved if the power supply is cut off as the result of a power failure.
- After the air purifier is turned on, the air quality light turns white while the sensor is stabilized. After about 30 seconds, the overall air quality display changes color based on the concentration of particles.

Using Purify Mode

This mode is for normal purification of indoor air.

- 1 Press the **Start/Stop** button to turn on the product.

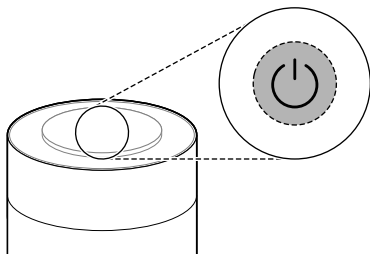

- 2 Press the **Mode** button to choose the **Purify** mode.

- Each time you press the button, the operating mode changes in the following order: **Purify** → **AI** → **Sleep**.

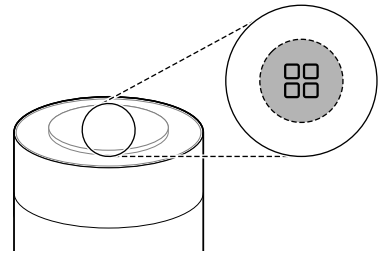

- 3 To adjust the fan speed, press the **Speed** button.
 - Each time the button is pressed, the fan speed changes in the order of **Auto** → **Low** → **Medium** → **High** → **Turbo**.

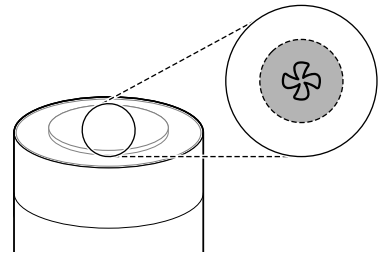

NOTE

- **Purify** mode is not displayed on the status panel.

Using AI Mode

Use **AI** mode to automatically adjust the operating mode and fan speed based on the overall air quality.

- 1 Press the **Start/Stop** button to turn on the product.

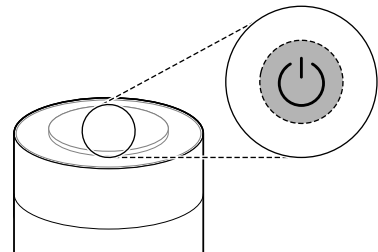

- 2** Press the **Mode** button to choose the **AI** mode.
- Each time you press the button, the operating mode changes in the following order: **Purify** → **AI** → **Sleep**.

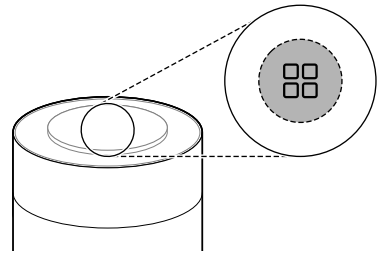
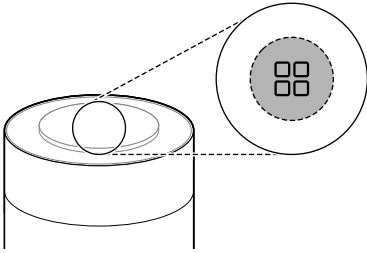

- 3** To adjust the fan speed, press the **Speed** button.
- Each time the button is pressed, the fan speed changes in the order of **Auto** → **Low** → **Medium** → **High** → **Turbo**.

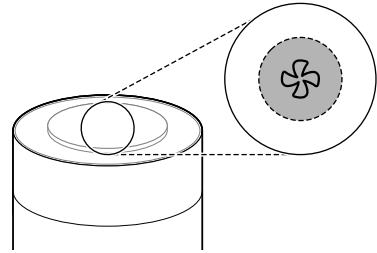

NOTE

- The fan speed of the air purifier is set automatically depending on the overall air quality.
- The fan speed cannot be adjusted during the **AI** mode.

Using Sleep Mode

Use this mode for quieter operation when you plan to sleep.

- 1** Press the **Start/Stop** button to turn on the product.

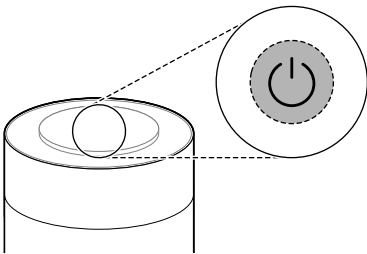

- 2** Press the **Mode** button to choose the **Sleep** mode.
- Each time you press the button, the operating mode changes in the following order: **Purify** → **AI** → **Sleep**.

NOTE

- The whole display is turned off except for the display of **Sleep** mode.
- The brightness of the letters in **Sleep** mode is reduced.
- You cannot set the operation time in **Sleep** mode separately. To cancel the **Sleep** mode, press the **Mode** button in the same way as in setting it.

Using the Extra Functions

Locking the Control Panel

Lock the buttons when you want to prevent children or pets from accidentally changing settings.

- Press and hold the **Ionizer** button for 3 seconds or longer during operation.

16 OPERATION

- The lock icon is displayed on the status panel when the lock function is set.

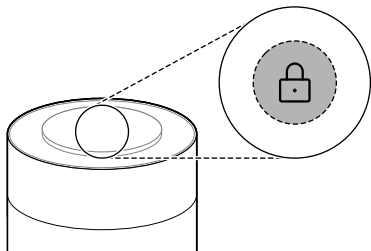

- The odor (gas) sensor stabilizes for approximately 2 minutes after operation begins.
-

NOTE

- Use the same method to turn the Lock function on or off.
 - The Lock function can be turned on or off whether the air purifier is running or not.
-

Turning On/Off the Air Quality Light

You can turn the air quality light on and off.

- 1** Press the **Start/Stop** button to turn on the product.

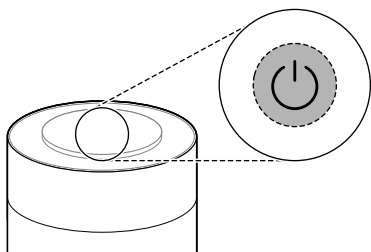

- 2** Press and hold the **Speed** button for 3 seconds or longer during operation.

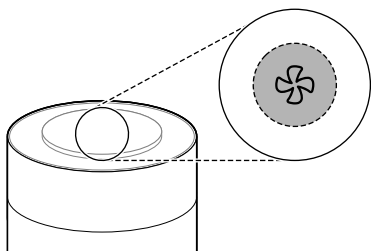

NOTE

- The overall air quality displays white during the sensor stabilization period (approximately 30 seconds).

Overall Air Quality

Understanding Overall Air Quality

The overall air quality is calculated based on the particles and odor (gas) concentrations and is categorized in 4 levels depending on the contamination of the air. (Green, Yellow, Orange, and Red)

Color	Overall air quality	Concentration of PM ($\mu\text{g}/\text{m}^3$)			Concentration of odor	
	State	PM10	PM2.5	PM1.0	State	Level
Red	Poor	255 or more	56 or more	56 or more	Very strong	4
Orange	Unhealthy	155 ~ 254	36 ~ 55	36 ~ 55	Strong	3
Yellow	Moderate	55 ~ 154	13 ~ 35	13 ~ 35	Normal	2
Green	Good	54 or less	12 or less	12 or less	Weak	1

NOTE

- The color of the overall air quality is based on the worst level detected, whether odors (gas) or particulates.
- PM concentration values are based on the data sheet provided by the sensor manufacturer.
- The PM concentration measurement was tested using LG Electronics' standard test materials.
- Differences in PM concentration values may be the result of different methods of measuring or differences in the actual PM concentration levels.
 - If the PM concentration is high, there may be a larger difference between the displayed concentration and the actual concentration.

SMART FUNCTIONS

LG ThinQ Application

The **LG ThinQ** application allows you to communicate with the appliance using a smartphone.

LG ThinQ Application Features

Smart Diagnosis

If you experience a problem while using the appliance, this **Smart Diagnosis** feature will help you diagnose the problem.

Settings

Allows you to set various options on the appliance and in the application.

NOTE

- In the following cases, you must update the network information for each appliance in the **LG ThinQ** application under **Device Cards** → **Settings** → **Change Network**.
 - wireless router is changed
 - wireless router password is changed
 - Internet service provider is changed
 - The application is subject to change for appliance improvement purposes without notice to users.
 - Functions may vary by model.
-

Installing LG ThinQ Application and Connecting an LG Appliance

Models with QR Code

Scan the QR code attached to the product using the camera or a QR code reader application on your smartphone.

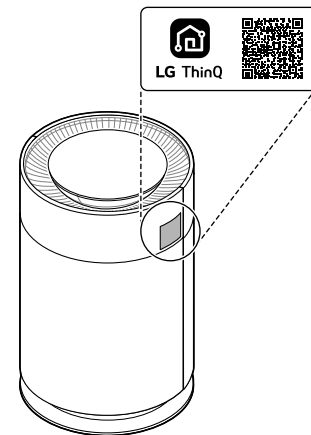

Models without QR Code

- 1** Search for and install the **LG ThinQ** application from the Google Play Store or Apple App Store on a smartphone.
- 2** Run the **LG ThinQ** application and sign in with your existing account or create an LG account to sign in.
- 3** Touch the add (+) button on the **LG ThinQ** application to connect your LG appliance. Follow the instructions in the application to complete the process.

NOTE

- To verify the Wi-Fi connection, check that the Wi-Fi indicator on the control panel is lit.
- The appliance supports 2.4 GHz Wi-Fi networks only. To check your network frequency, contact your Internet service provider or refer to your wireless router manual.
- **LG ThinQ** is not responsible for any network connection problems or any faults, malfunctions, or errors caused by network connection.

- The surrounding wireless environment can make the wireless network service run slowly.
- If the distance between the appliance and the wireless router is too far, the signal strength becomes weak. It may take a long time to connect or installation may fail.
- If the appliance is having trouble connecting to the Wi-Fi network, it may be too far from the router. Purchase a Wi-Fi repeater (range extender) to improve the Wi-Fi signal strength.
- The network connection may not work properly depending on the Internet service provider.
- The Wi-Fi connection may not connect or may be interrupted because of the home network environment.
- If the appliance cannot be connected due to problems with the wireless signal transmission, unplug the appliance and wait about a minute before trying again.
- The wireless network name (SSID) should be a combination of English letters and numbers. (Do not use special characters.)
- Smartphone user interface (UI) may vary depending on the mobile operating system (OS) and the manufacturer.
- If the security protocol of the router is set to **WEP**, the network setup may fail. Change to another security protocol (**WPA2** is recommended) and connect the product again.

can radiate radio frequency energy and, if not installed and used in accordance with the instructions, may cause harmful interference to radio communications. However, there is no guarantee that interference will not occur in a particular installation. If this equipment does cause harmful interference to radio or television reception, which can be determined by turning the equipment off and on, the user is encouraged to try to correct the interference by one or more of the following measures:

- Reorient or relocate the receiving antenna.
- Increase the separation between the equipment and the receiver.
- Connect the equipment into an outlet on a circuit different from that to which the receiver is connected.
- Consult the dealer or an experienced radio/TV technician for help.

This device complies with part 15 of the FCC Rules. Operation is subject to the following two conditions:

- (1) This device may not cause harmful interference and
- (2) This device must accept any interference received, including interference that may cause undesired operation.

Any changes or modifications in construction of this device which are not expressly approved by the party responsible for compliance could void the user's authority to operate the equipment.

Radio Equipment Specifications

Type	Operating Frequency Range	Output Power (Max.)
Wireless LAN	2400 MHz - 2472 MHz	< 1 W
Bluetooth [†]	2400 MHz - 2483.5 MHz	

[†] This feature is only available on some models.

FCC Notice

The following notice covers the transmitter module contained in this product.

This equipment has been tested and found to comply with the limits for a Class B digital device, pursuant to Part 15 of the FCC Rules. These limits are designed to provide reasonable protection against harmful interference in a residential installation. This equipment generates, uses, and

FCC RF Radiation Exposure Statement

This equipment complies with FCC radiation exposure limits set forth for an uncontrolled environment. This transmitter must not be co-located or operating in conjunction with any other antenna or transmitter.

This equipment should be installed and operated with a minimum distance of 20 cm (7.8 inches) between the antenna and your body. Users must follow the specific operating instructions for satisfying RF exposure compliance.

Open Source Software Notice Information

To obtain the source code that is contained in this product, under GPL, LGPL, MPL, and other open source licenses that have the obligation to disclose source code, and to access all referred license

terms, copyright notices, please visit <https://opensource.lge.com>.

LG Electronics will also provide open source code to you for a charge covering the cost of performing such distribution upon email request to opensource@lge.com.

This offer is valid to anyone in receipt of this information for a period of three years after our last shipment of this product.

Smart Diagnosis

Use this feature to help you diagnose and solve problems with your appliance.

NOTE

- For reasons not attributable to LGE's negligence, the service may not operate due to external factors such as, but not limited to, Wi-Fi unavailability, Wi-Fi disconnection, local app store policy, or app unavailability.
 - The feature may be subject to change without prior notice and may have a different form depending on where you are located.
-

Using LG ThinQ to Diagnose Issues

If you experience a problem with your Wi-Fi equipped appliance, it can transmit troubleshooting data to a smartphone using the **LG ThinQ** application.

- Launch the **LG ThinQ** application and select the **Smart Diagnosis** feature in the menu. Follow the instructions provided in the **LG ThinQ** application.

Using Audible Diagnosis to Diagnose Issues

Follow the instructions below to use the audible diagnosis method.

- Launch the **LG ThinQ** application and select the **Smart Diagnosis** feature in the menu. Follow the instructions for audible diagnosis provided in the **LG ThinQ** application.

- 1** Press and hold the **Mode** and **Ionizer** buttons for 3 seconds to execute the **Smart Diagnosis** function.

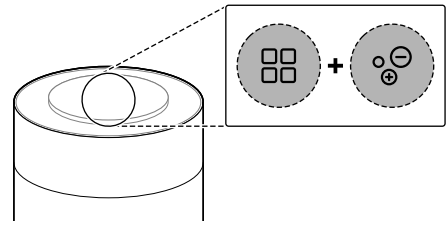

- 2** Place your smartphone near the product.
 - Make sure the microphone of the smartphone faces the front of the product.

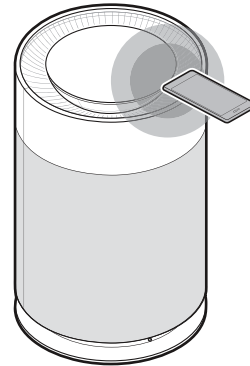

- 3** When data transmission is complete, the **Smart Diagnosis** result will be displayed on the **LG ThinQ** Application.

NOTE

- For accurate diagnosis, do not move the smartphone away from the product until the beeping stops.
 - Keep quiet around the product during **Smart Diagnosis**.
-

MAINTENANCE

Maintaining the Product

Scheduled Maintenance

⚠ WARNING

- Stop the appliance operation and unplug the power cord before cleaning and replacing the filter.
- Do not spray water directly on the appliance.

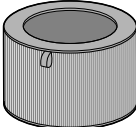
Component	Cleaning frequency	Replacement frequency
 <p>Filter</p>	<p>Pre-Filter Clean filter as needed</p>	<p>1 year</p>

NOTE

- The color of the filter may vary depending on the usage environment and color of dust.
- The cleaning frequency may vary depending on the operating hours and environment of the appliance.
- If you do not clean the product according to the cleaning frequency, you may experience a bad odor and poor performance.
- The filter must be replaced at the end of its lifespan, and the cost of replacement filters is not covered under the warranty. To purchase new filters, contact an LG Electronics Customer Information Center or visit the website at www.lg.com

- Never use sulphuric acid, hydrochloric acid or organic solvent (for example, thinner, kerosene and acetone) to wipe the appliance exterior, or affix labels on the exterior. Doing so may damage the product surface.
- Care should be exercised to prevent water from entering the product.

NOTE

- If it is difficult to remove dust from the front and rear covers, disassemble the covers and clean them with water. After cleaning, dry the covers thoroughly in the shade.

Cleaning the Particle Sensor

The PM1.0 sensor detects fine dust and large dust contamination levels, so it is beneficial to clean the lens periodically, at least once every 2 months.

- 1 Hold the top of the front cover with the **LG logo** on it. Pull the cover forward to remove it.

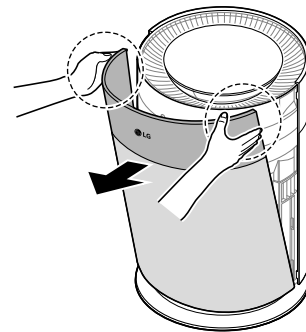

- 2 Open the sensor cover.

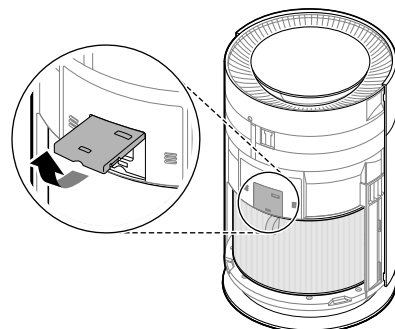

Cleaning the Exterior

- 1 Remove dust from the air inlet and outlet using a vacuum cleaner.
- 2 Wipe the exterior of the product with a soft cloth.

⚠ CAUTION

- Do not wipe the appliance with an alkaline detergent.

- 3** Clean the lens with a cotton swab soaked with water and wipe it dry with a dry cotton swab.

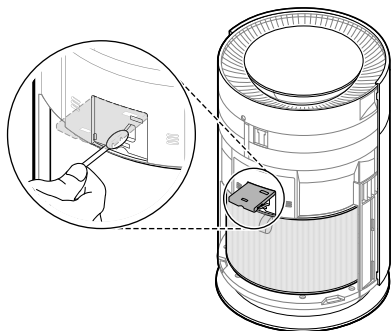

- 4** Close the sensor cover.

NOTE

- Do not wipe the sensor with any substances other than water. Doing so may cause the appliance to malfunction.
 - It is normal for the sensor cover to make a sound when opened or closed.
-

Replacing the Filters

- 1 Remove the cover of the product, and replace the filter.
 - To avoid spreading dust when replacing the filter, place a newspaper or paper towels on the floor before removing the filter.
- 2 When you finish replacing the filter, turn off the Filter Replacement Notification.

NOTE

- The Filter Replacement Notification is turned on according to the maximum period of use, considering the operating time of the product. The replacement interval may vary depending on the hours of use and the environment.

Turning off Filter Replacement Notification

 Filter Replacement Notification

Press and hold the **Mode** and **Speed** buttons on the control panel for 3 seconds or more.

- Filter Replacement Notification on the status panel is turned off and the time for Filter Replacement Notification is reset.

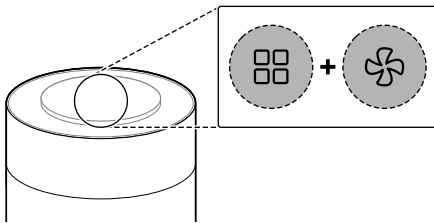

NOTE

- Use when replacing the filter.

Replacing the Pre-Filter

To replace the ultra-fine-filter, locate the Velcro and separate it slowly and carefully to remove the pre-filter.

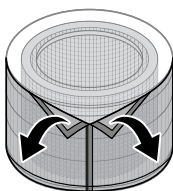

Cleaning the Filters

- 1 Remove the front and rear covers from the product.

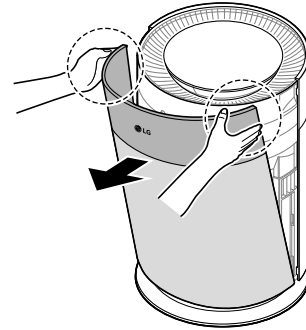

- 2 Using a vacuum cleaner or soft brush, remove any dust from the pre-filter surrounding the filter.

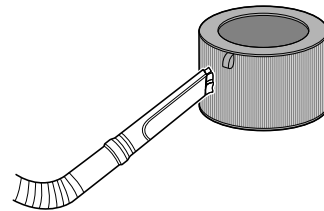

CAUTION

- Do not clean the filter with water. The service life of the filter may be reduced.
- Be careful not to damage the pre-filter when using a vacuum cleaner.
- Take caution because there is a risk of tearing or loss when removing or assembling the pre-filter.
- Take care to avoid getting liquid on the filter, as it may damage the filter.

Storage

If the product will not be used for a long period of time, store it in a dry and shaded place.

- 1 Operate the product for one hour or more on a fine day.
 - This removes moisture and prevents it from building up inside the product.

24 MAINTENANCE

- 2 Turn off the power and unplug the product from the electrical outlet.
 - Separate the adapter from the product and store it.

- 3 Cover the appliance to prevent dust or foreign substances from entering the appliance. Store the covered appliance out of direct sunlight.

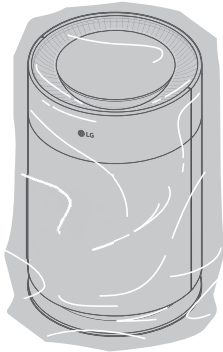

⚠ CAUTION

- Do not store the appliance in a humid location or in an area exposed to direct sunlight. If you do so, the appliance may be deformed, malfunction or generate odor.
-

TROUBLESHOOTING

Before Calling for Service

Please check the following before calling for service. If the problem persists, contact your local service center.

Operation

Problem	Possible Cause & Solution
The product does not power on.	Is the power plug disconnected? <ul style="list-style-type: none"> Connect it to an outlet correctly.
	Did the electricity get cut off? <ul style="list-style-type: none"> Check the power to other products in the house.
A noise occurs and the fan speed is low.	Has dust accumulated in the pre-filter? <ul style="list-style-type: none"> Clean the pre-filter.
	Has dust accumulated in the filter? <ul style="list-style-type: none"> Replace the filter.
Air purification is not done properly.	Is the indoor pollution severe? <ul style="list-style-type: none"> Ventilate indoors before using the product.
	Has dust accumulated in the pre-filter? <ul style="list-style-type: none"> Clean the pre-filter.
	Has dust accumulated in the filter? <ul style="list-style-type: none"> Replace the filter.
	Are you using it in a place that is too spacious or too open? <ul style="list-style-type: none"> Use a product that suits the size of the room. Avoid well-ventilated places such as doors, windows, etc.
	Is there an obstacle nearby? <ul style="list-style-type: none"> Remove any nearby obstacles before operating the product.
	Is the product installed in a corner? <ul style="list-style-type: none"> Move the product and reinstall it.
The color of the overall air quality stays red.	Move the appliance to a different room and see if the color changes. <ul style="list-style-type: none"> Clean the PM1.0 sensor. Remove the power plug from the outlet and reconnect it one minute later.
	A substance was sprayed near the product. <ul style="list-style-type: none"> Do not use sprays near the product.
The buttons on the control panel do not work.	Is the lock icon displayed on the status panel? <ul style="list-style-type: none"> Press and hold the Ionizer button for 3 seconds to disable the lock function.
The color of the filter status notification does not change to green.	Is the color of the filter status notification orange or red? <ul style="list-style-type: none"> The filter status notification can be reset through the additional filter status notification reset function. <ul style="list-style-type: none"> Press and hold the Mode and Speed buttons on the control panel for 3 seconds.

Odor

Problem	Possible Cause & Solution
<p>A strange odor comes out of the air outlet as well as the filter.</p>	<p>Did you purchase the product recently?</p> <ul style="list-style-type: none"> • This is the odor of activated charcoal, and is not harmful. This is similar to the odor you may experience in a brand new car. It will go away within a day following use.
	<p>Is the product used in a place with a lot of smoke or odors?</p> <ul style="list-style-type: none"> • If the air purifier is operated after an air freshener, diffuser, or scented candle has been used, or interior work or wallpaper replacement have occurred, the filter may absorb and emit an odor. Ventilate the room first before using the product.
	<p>Does the filter have a bad smell?</p> <ul style="list-style-type: none"> • The filter replacement cycle may vary depending on the usage environment. If there is an odor, replace the filter with a new one.
	<p>Is it in an environment in which food is prepared?</p> <ul style="list-style-type: none"> • If you use the product for a long period of time where you cook or broil fish/meat, the filter lifespan may be significantly decreased. • If possible, open a window for ventilation while cooking, and use the product to remove any odors left following ventilation.
	<p>Is it a humid environment?</p> <ul style="list-style-type: none"> • The filter may emit an odor if used in a humid environment. Dry the filter in sunlight before use.

LG ThinQ

Problem	Possible Cause & Solution
<p>The product and the smartphone cannot be connected through Wi-Fi.</p>	<p>Is the Wi-Fi password used to connect to the smartphone correct?</p> <ul style="list-style-type: none"> • Press the Settings button on your smartphone, and then find your Wi-Fi in the network list. Press and hold the button to select [Clear Network], and then proceed with product registration again from the beginning.
	<p>Is your smartphone using mobile data rather than Wi-Fi?</p> <ul style="list-style-type: none"> • In the smartphone's settings, turn off Mobile Data, turn on Wi-Fi, and then register the product.
	<p>Does the name (ID) of the wireless router contain special characters?</p> <ul style="list-style-type: none"> • Set the name (ID) of the wireless router as a combination of numbers and English letters. Wi-Fi connection may be difficult if you enter special characters.
	<p>Is the frequency of the wireless router not 2.4 GHz?</p> <ul style="list-style-type: none"> • When connecting the product via Wi-Fi, only a 2.4 GHz network can be used. Set the wireless router to 2.4 GHz and then connect. To check the frequency of your wireless router, contact your Internet carrier or router manufacturer.
	<p>Are the product and the wireless router too far apart?</p> <ul style="list-style-type: none"> • If the distance between the product and the wireless router is too great, the wireless signal may be weak, and the connection may not be smooth. Move the wireless router closer to the product.

APPENDIX

Information

APPLIANCE SPECIFICATIONS

- Appearance and specifications may vary without notice to improve the quality of the appliance.

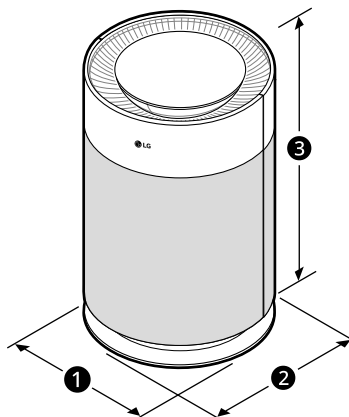

Name	AS60GHHG0
Power	DC 24 V
Exterior Dimensions (① x ② x ③)	12.4" x 12.4" x 20.1" (315 mm x 315 mm x 511 mm)

AC/DC Adapter

Manufacturer	FOSHAN SHUNDE GUANYUDA POWER SUPPLY CO.,LTD.
Model	GM51-240200-4A
Rated Input	AC 100 V - 240 V ~, 50/60 Hz
Rated Output	DC 24 V, 2.0 A, 48 W

LIMITED WARRANTY

USA

ARBITRATION NOTICE:

THIS LIMITED WARRANTY CONTAINS AN ARBITRATION PROVISION THAT REQUIRES YOU AND LG ELECTRONICS ("LG") TO RESOLVE DISPUTES BY BINDING ARBITRATION INSTEAD OF IN COURT, UNLESS YOU CHOOSE TO OPT OUT. IN ARBITRATION, CLASS ACTIONS AND JURY TRIALS ARE NOT PERMITTED. PLEASE SEE THE SECTION TITLED "PROCEDURE FOR RESOLVING DISPUTES" BELOW.

WHAT THIS WARRANTY COVERS:

Should your LG Air Purifier ("Product") fail due to a defect in materials or workmanship under normal and proper use, during the warranty period set forth below, LG will, at its option, repair or replace the Product. This limited warranty is valid only to the original retail purchaser of the Product ("You") and applies only when purchased lawfully and used within the United States including U.S. Territories.

NOTE

- Replacement Products and parts are warranted for the remaining portion of the original warranty period or ninety (90) days, whichever is greater.
 - Replacement Products and parts may be new, reconditioned, refurbished, or otherwise factory remanufactured.
 - Replaced Product or part(s) will be the property of LG.
 - Proof of original retail purchase specifying the Product model and date of purchase is required to obtain warranty service under this limited warranty.
-

INFORMATION

WARRANTY PERIOD:

One (1) year from the date of original retail purchase, or from the date of delivery as per applicable law:
Any internal/ functional Parts and Labor

HOW SERVICE IS HANDLED: In-Home Service

In-home service will be provided during the warranty period subject to availability within the United States. In-home service may not be available in all areas. To receive in-home service, the product must be unobstructed and accessible to service personnel. If during in-home service repair cannot be completed, it may be necessary to remove, repair and return the product. If in-home service is unavailable, LG may elect, at our option, to provide for transportation of our choice to and from an LG authorized service center.

EXCEPT TO THE EXTENT PROHIBITED BY APPLICABLE LAW, ANY IMPLIED WARRANTY OF MERCHANTABILITY OR FITNESS FOR A PARTICULAR PURPOSE ON THE PRODUCT IS LIMITED IN DURATION TO THE DURATION OF THE ABOVE LIMITED WARRANTY. UNDER NO CIRCUMSTANCES SHALL LG OR ITS U.S. DISTRIBUTORS/ DEALERS BE LIABLE FOR ANY INDIRECT, INCIDENTAL, CONSEQUENTIAL, SPECIAL, OR PUNITIVE DAMAGES, INCLUDING, WITHOUT LIMITATION, LOST GOODWILL,

LOST REVENUES OR PROFITS, WORK STOPPAGE, IMPAIRMENT OF OTHER GOODS, COST OF REMOVAL AND REINSTALLATION OF THE PRODUCT, LOSS OF USE, OR ANY OTHER DAMAGES WHETHER BASED IN CONTRACT, TORT, OR OTHERWISE. LG'S TOTAL LIABILITY, IF ANY, SHALL NOT EXCEED THE PURCHASE PRICE PAID BY YOU FOR THE PRODUCT.

SOME STATES DO NOT ALLOW THE EXCLUSION OR LIMITATION OF INCIDENTAL OR CONSEQUENTIAL DAMAGES OR LIMITATIONS ON HOW LONG AN IMPLIED WARRANTY LASTS, SO THE ABOVE EXCLUSIONS OR LIMITATIONS MAY NOT APPLY TO YOU. THIS LIMITED WARRANTY GIVES YOU SPECIFIC LEGAL RIGHTS AND YOU MAY ALSO HAVE OTHER RIGHTS THAT VARY FROM STATE TO STATE.

THIS LIMITED WARRANTY DOES NOT COVER:

- Service trips to deliver, pick up, or install, educate how to operate, correct wiring, or correct unauthorized repairs.
- Damage or failure of the Product to perform during power failures and interrupted or inadequate electrical service.
- Damage or failure of the Product caused by leaky or broken water pipes, frozen water pipes, restricted drain lines, inadequate or interrupted water supply or inadequate supply of air.
- Damage or failure of the Product resulting from operating the Product in a corrosive atmosphere or contrary to the Product owner's manual.
- Damage or failure of the Product caused by accidents, pests and vermin, lightning, wind, fire, floods, acts of nature, or any other causes beyond the control of LG.
- Damage or failure of the Product caused by unauthorized modification or alteration, or if the Product is used for other than the intended purpose, or any water leakage where the Product was not properly installed.
- Damage or failure of the Product caused by incorrect electrical current, voltage, or plumbing codes.
- Damage or failure of the Product caused by transportation, storage, and/or handling, including scratches, dents, chips, and/or other damage to the finish of the Product, unless such damage is reported within one (1) week of delivery.
- Damage or failure of the Product resulting from misuse, abuse, improper installation, repair, or maintenance. Improper repair includes the use of parts not authorized by LG. Improper installation or maintenance includes installation or maintenance contrary to the Product owner's manual.
- Damage or failure of the Product caused by the use of parts, components, accessories, consumable cleaning products, or any other products or services that were not authorized by LG.
- Damage or missing items to any display or open box Product.
- Refurbished Product or any Product sold "As Is", "Where Is", "With all Faults", or similar disclaimer.
- Products with original serial numbers that have been removed, altered, or cannot be readily determined.
- Increases in utility costs and additional utility expenses.
- Any noises associated with normal operation.
- Products used for other than normal and proper household use (e.g., commercial or industrial use) or contrary to the Product owner's manual.
- Costs associated with removal and reinstallation of the Product for repairs, or the removal and reinstallation of the Product if it is installed in an inaccessible location or not installed in accordance with the Product Owner's manual.
- Accessories, removable components, or consumable parts (e.g. Shelves, door bins, drawers, water/air filters, racks, light bulbs, batteries, etc., as applicable), except for internal/functional parts covered under this limited warranty.
- Replacing house fuses or resetting of circuit breakers, correction of house wiring or plumbing, or correction of product installation.

The cost of repair or replacement under these excluded circumstances shall be borne by You.

TO OBTAIN WARRANTY SERVICE AND ADDITIONAL INFORMATION

Call 1-800-243-0000 and select the appropriate option from the menu. Or visit our website at <http://www.lg.com>

Or by mail: LG Customer Information Center (ATTN: CIC) 201 James Record Road, Huntsville, AL 35824

PROCEDURE FOR RESOLVING DISPUTES:

ALL DISPUTES BETWEEN YOU AND LG ARISING OUT OF OR RELATING IN ANY WAY TO THIS LIMITED WARRANTY OR THE PRODUCT SHALL BE RESOLVED EXCLUSIVELY THROUGH BINDING ARBITRATION, AND NOT IN A COURT OF GENERAL JURISDICTION. BINDING ARBITRATION MEANS THAT YOU AND LG ARE EACH WAIVING THE RIGHT TO A JURY TRIAL AND TO BRING OR PARTICIPATE IN A CLASS ACTION.

Definitions. For the purposes of this section, references to “LG” mean LG Electronics U.S.A., Inc., its parents, subsidiaries and affiliates, and each of their officers, directors, employees, agents, beneficiaries, predecessors in interest, successors, assigns and suppliers; references to “dispute” or “claim” shall include any dispute, claim or controversy of any kind whatsoever (whether based in contract, tort, statute, regulation, ordinance, fraud, misrepresentation or any other legal or equitable theory) arising out of or relating in any way to the sale, condition or performance of the product or this Limited Warranty.

Notice of Dispute. In the event you intend to commence an arbitration proceeding, you must first notify LG in writing at least 30 days in advance of initiating the arbitration by sending a letter to LG at LG Electronics, USA, Inc. Attn: Legal Department-Arbitration 111 Sylvan Avenue, Englewood Cliffs, NJ 07632. You and LG agree to engage in good faith discussions in an attempt to amicably resolve your claim. The notice must provide your name, address, and telephone number; identify the product that is the subject of the claim; and describe the nature of the claim and the relief being sought. If you and LG are unable to resolve the dispute within 30 days, either party may proceed to file a claim for arbitration.

Agreement to Binding Arbitration and Class Action Waiver. Upon failure to resolve the dispute during the 30 day period after sending written notice to LG, you and LG agree to resolve any claims between us only by binding arbitration on an individual basis, unless you opt out as provided below. Any dispute between you and LG shall not be combined or consolidated with a dispute involving any other person’s or entity’s product or claim. More specifically, without limitation of the foregoing, any dispute between you and LG shall not under any circumstances proceed as part of a class or representative action. Instead of arbitration, either party may bring an individual action in small claims court, but that small claims court action may not be brought on a class or representative basis.

Arbitration Rules and Procedures. To begin arbitration of a claim, either you or LG must make a written demand for arbitration. The arbitration will be administered by the American Arbitration Association (“AAA”) and will be conducted before a single arbitrator under the AAA’s Consumer Arbitration Rules that are in effect at the time the arbitration is initiated (referred to as the “AAA Rules”) and under the procedures set forth in this section. The AAA Rules are available online at www.adr.org/consumer. Send a copy of your written demand for arbitration, as well as a copy of this provision, to the AAA in the manner described in the AAA Rules. You must also send a copy of your written demand to LG at LG Electronics, USA, Inc. Attn: Legal Department-Arbitration 111 Sylvan Avenue, Englewood Cliffs, NJ 07632. If there is a conflict between the AAA Rules and the rules set forth in this section, the rules set forth in this section will govern. This arbitration provision is governed by the Federal Arbitration Act. Judgment may be entered on the arbitrator’s award in any court of competent jurisdiction. All issues are for the arbitrator to decide, except that issues relating to the scope and enforceability of the arbitration provision and to the arbitrability of the dispute are for the court to decide. The arbitrator is bound by the terms of this provision.

Governing Law. The law of the state of your residence shall govern this Limited Warranty and any disputes between us except to the extent that such law is preempted by or inconsistent with applicable federal law.

Fees/Costs. You do not need to pay any fee to begin an arbitration. Upon receipt of your written demand for arbitration, LG will promptly pay all arbitration filing fees to the AAA unless you seek more than \$25,000 in damages, in which case the payment of these fees will be governed by the AAA Rules. Except as otherwise provided for herein, LG will pay all AAA filing, administration and arbitrator fees for any arbitration initiated in accordance with the AAA Rules and this arbitration provision. If you prevail in the arbitration, LG will pay your attorneys’ fees and expenses as long as they are reasonable, by considering factors including, but not limited to, the purchase amount and claim amount. Notwithstanding the foregoing, if applicable law allows for an award of reasonable attorneys’ fees and expenses, an arbitrator can award them to the same extent that a court would. If the arbitrator finds either the substance of your claim or the relief sought in the demand is frivolous or brought for an improper purpose (as measured by the standards set forth in Federal Rule of Civil Procedure 11(b)), then the payment of all arbitration fees will be governed by the AAA Rules. In such a situation, you agree to reimburse LG for all monies previously disbursed by it that are otherwise your obligation to pay under the AAA Rules. Except as otherwise

provided for, LG waives any rights it may have to seek attorneys' fees and expenses from you if LG prevails in the arbitration.

Hearings and Location. If your claim is for \$25,000 or less, you may choose to have the arbitration conducted solely on the basis of (1) documents submitted to the arbitrator, (2) through a telephonic hearing, or (3) by an in-person hearing as established by the AAA Rules. If your claim exceeds \$25,000, the right to a hearing will be determined by the AAA Rules. Any in-person arbitration hearings will be held at a location within the federal judicial district in which you reside unless we both agree to another location or we agree to a telephonic arbitration.

Opt Out. You may opt out of this dispute resolution procedure. If you opt out, neither you nor LG can require the other to participate in an arbitration proceeding. To opt out, you must send notice to LG no later than 30 calendar days from the date of the first consumer purchaser's purchase of the product by either: (i) sending an e-mail to optout@lge.com, with the subject line: "Arbitration Opt Out" or (ii) calling 1-800-980-2973. You must include in the opt out e-mail or provide by telephone: (a) your name and address; (b) the date on which the product was purchased; (c) the product model name or model number; and (d) the serial number (the serial number can be found (i) on the product; or (ii) online by accessing <https://www.lg.com/us/support/repair-service/schedule-repair-continued> and clicking on "Find My Model & Serial Number").

You may only opt out of the dispute resolution procedure in the manner described above (that is, by e-mail or telephone); no other form of notice will be effective to opt out of this dispute resolution procedure. Opting out of this dispute resolution procedure will not affect the coverage of the Limited Warranty in any way, and you will continue to enjoy the full benefits of the Limited Warranty. If you keep this product and do not opt out, then you accept all terms and conditions of the arbitration provision described above.



LG Electronics USA, Inc.
111 Sylvan Avenue, Englewood Cliffs, NJ 07632

LG Customer Information Center	Centro de Información al Cliente LG	Centre de Service à la Clientèle de LG
For inquiries or comments, visit www.lg.com or call: 1-800-243-0000 U.S.A. 1-888-542-2623 CANADA	Para consultas o comentarios, visite www.lg.com o llame por teléfono: 1-800-243-0000 EE.UU. 1-888-542-2623 CANADÁ	Pour des questions ou des commentaires, visitez www.lg.com/ca_fr ou appelez : 1-800-243-0000 ÉTATS-UNIS 1-888-542-2623 CANADA
Register your product Online!	¡Registre su producto en línea!	Enregistrez votre produit en ligne!
www.lg.com	www.lg.com	www.lg.com/ca_fr