

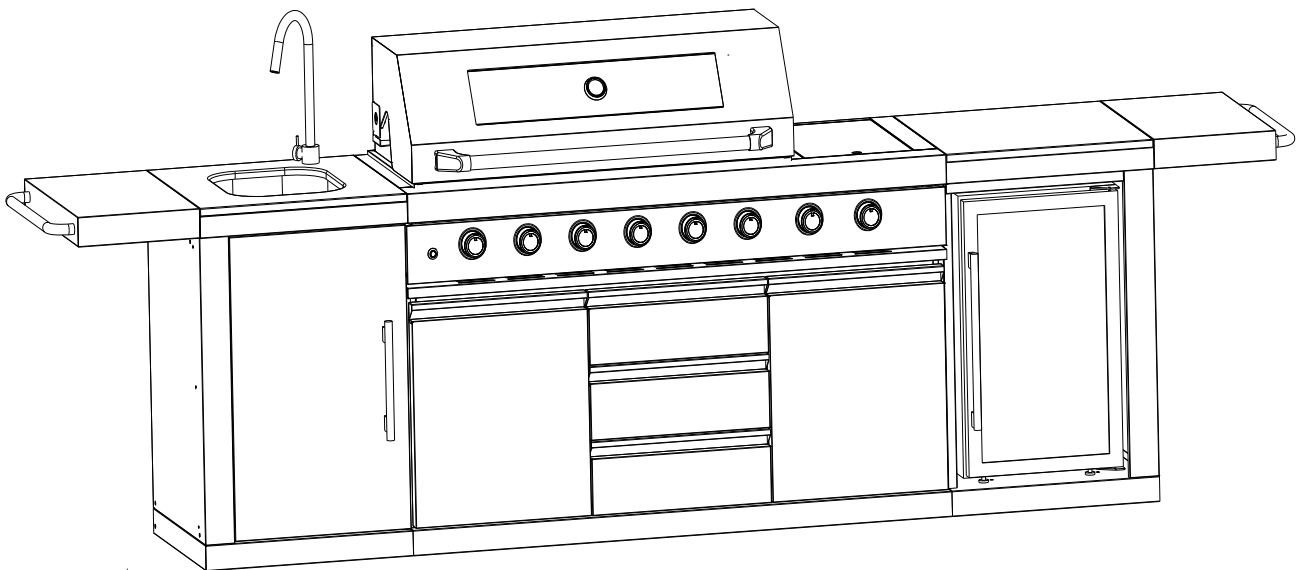

Outdoor Kitchen Island

Model No: V-SERA

Assembly Instructions & User's Manual



CE 2459

Keep this manual for future reference

⚠ Warning:

READ INSTRUCTION MANUAL BEFORE ATTEMPTING TO ASSEMBLE OR OPERATE THIS PRODUCT.

Adult assembly required.

Keep screws and parts out of reach of children.

SAFETY WARNING

RECOGNIZED SAFETY SYMBOLS, WORDS AND LABELS



WARNING

Do not try lighting this appliance without first reading the "LIGHTING INSTRUCTIONS" section of this manual.

INSECT WARNING!!! Spiders and insects can nest in the burners of this and any other grill, and cause improper gas flow. This is a very dangerous condition, which can cause fire behind and beneath the valve panel, thereby damaging the grill and making it unsafe to operate. Inspect the grill for this at least twice a year.

LP gas cylinder must be fitted with Overfill Protection Device (OPD).



WARNING

- DO NOT store a spare LP-gas cylinder under or near this appliance.
- NEVER fill the cylinder beyond 80% full.
- If the information in "a" and "b" is not followed exactly, a fire causing death or serious injury may occur.



DANGER

If you smell gas:

- Shut off gas to the appliance.
- Extinguish any open flame.
- Open lid.
- If odor continues, keep away from the appliance and immediately call your gas supplier or your fire department.



WARNING

- Do not store or use gasoline or other flammable liquids or vapors in the vicinity of this or any other appliance.
- An LP cylinder not connected for use shall not be stored in the vicinity of this or any other appliance.

DO NOT USE ALUMINUM FOIL TO LINE THE GRILL RACKS OR GRILL BOTTOM. This can severely upset combustion airflow or trap excessive heat in the control area.

GAS INSTALLATION CODES

The installation must conform with local codes or, in the absence of local codes, with either the National Fuel Gas Code, ANSI Z223.1/NFPA 54, or the Natural Gas and Propane Installation Code, CSA B149.1, or the Propane Storage and Handling Code, CSA B149.2.

DO NOT LEAVE THE GRILL UNATTENDED WHILE COOKING.



WARNING: Always keep your face and body as far away from the burner as possible when lighting.



WARNING: IMPORTANT!

BEFORE LIGHTING

Inspect the hose before each use of the outdoor cooking gas appliance. If it is evident there is excessive abrasion or wear, or the hose is cut, it must be replaced prior to the outdoor cooking gas appliance being put into operation. Do not use the grill if the odor of gas is present. Only the pressure regulator and hose assembly supplied with the outdoor cooking gas appliance must be used. Never substitute regulators for those supplied with the grill. If a replacement is necessary, contact the customer service number below for proper replacement.

Attach regulator onto the cylinder. Check the leaks in the hose and regulator connections using a soap and water solution before operating the grill.

Keep a spray bottle of soap water near the gas supply valve and check the connections before each use. See leak testing section.

Do not attempt to light the grill if odor of gas is present. Call for customer service of your retailer.

TABLE OF CONTENTS

Safety Warning.....	2,4-5
Placement of the Grill.....	6
Exploded View.....	7
Parts List.....	8
Assembly Instructions.....	9-12
Gas Cylinder Installation Instructions.....	13
GRILL LIGHTS -operation and bule replacement.....	13
Gas Hook-Up.....	14
Gas Safety.....	15
Leak Testing.....	16
Lighting Instructions	17 -21
Main Burners' Lighting Instructions.....	17
Rear Burner's Lighting Instructions.....	17
Rotisserie Operating Instructions.....	18-19
Side Burner Lighting Instructions.....	19
Charcoal Pan Operating Instructions.....	20
To Match Light The Grill.....	21
Grilling Guide.....	22-23
Care & Maintenance	24
Trouble Shooting.....	25-27
Warranty Information	28

Read this User Manual carefully and completely before using your grill to reduce the risk of fire, burn hazard or other injury.

Note: Before beginning assembly of product, make sure all parts are present. Compare parts with package content list and hardware contents. If any part is missing or damaged, do not attempt to assemble the unit. Contact customer service for replacement parts.

SAFETY WARNING

TESTED IN ACCORDANCE WITH CSA/ANSI Z21.58-2022·CSA 1.6-2022 STANDARD FOR OUTDOOR COOKING GAS APPLIANCES.

⚠ WARNING: This product can expose you to chemicals including soot, which is known to the State of California to cause cancer, and carbon monoxide, which is known to the State of California to cause birth defects or other reproductive harm. For more information, go to www.P65Warnings.ca.gov.

SAFETY PRACTICES TO AVOID PERSONAL INJURY

When properly cared for, your grill will give safe, reliable service for many years. However, extreme care must be used since the grill produces intense heat and that can increase accident potential. When using this appliance basic safety practices must be followed, including the following:

THIS OUTDOOR COOKING GAS APPLIANCE SHALL BE USED ONLY OUTDOORS. NEVER used in a building, garage or any other enclosed area.

This outdoor cooking gas appliance is not intended to be installed in or on recreational vehicles and/or boats.

The outdoor cooking gas appliance shall not be used under overhead combustible construction.

Do not repair or replace any part of the grill unless specifically recommended in this manual. All other service should be referred to a qualified technician.

CHILDREN SHOULD NOT BE LEFT ALONE OR UNATTENDED IN AN AREA WHERE THE GRILL IS BEING USED. NEVER ALLOW THEM TO SIT, STAND OR PLAY ON OR AROUND THE GRILL AT ANY TIME.

DO NOT STORE ITEMS OF INTEREST TO CHILDREN AROUND OR BELOW THE GRILL OR IN THE CART. NEVER ALLOW CHILDREN TO CRAWL INSIDE OF THE CART.

Never let clothing, pot holders or other flammable materials come in contact with or too close to any grate, burner or hot surface until it has cooled. Fabric may ignite and result in personal injury.

For personal safety, wear proper apparel. Loose fitting garments or sleeves should never be worn while using this appliance. Some synthetic fabrics are highly flammable and should not be worn while cooking.

Only certain types of glass, heatproof glass ceramic, earthenware, or other glazed utensils are suitable for grill use. These types of materials may break with sudden temperature changes. Use only on low or medium heat settings according to the manufacturer's directions.

Do not heat unopened food containers as a build-up of pressure may cause the container to burst.

Never lean over an open grill.

SAFETY WARNING

When using the grill, do not touch the grill rack, burner grate or immediate surroundings as these areas become extremely hot and could cause burns. Use only dry potholders. Moist or damp potholders on hot surfaces may cause burns from steam. Do not use a towel or bulky cloth in place of potholders. Do not let potholders touch hot portions of the grill rack.

Grease is flammable. Let hot grease cool before attempting to handle it. Avoid letting excess grease deposits collect in the grease slide panel bottom at the bottom of the grill's firebox. Clean this area often.

For proper lighting and performance of the burners, keep the burner ports clean. It is necessary to clean them periodically for optimum performance. The burners will only operate in one position and must be mounted correctly for safe operation.

Clean the grill with caution. Avoid steam burns; do not use a wet sponge or cloth to clean the grill while it is hot. Some cleaners produce noxious fumes or can ignite if applied to a hot surface.

Be sure all grill controls are turned off and the grill is cool before using any type of aerosol cleaner on or around the grill. The chemical that produces the spraying action could, in the presence of heat, ignite or cause metal parts to corrode.

Do not use the grill for cooking excessively fatty meats or products, which promote flare-ups.

Keeping outdoor cooking gas appliance area clear and free from combustible materials, gasoline and other flammable vapors and liquids.

Do not obstruct the flow of combustion and ventilation air.

If the unit is stored indoors ensure that it is cool.

If propane is used, the cylinder must be unhooked and the propane cylinder stored outside in a well-ventilated area, out of the reach of children.

DO NOT USE BRIQUETTES OF ANY KIND IN THE GRILL.

The grill is designed for optimum performance without the use of briquettes. Do not place briquettes on the flame tamers as this will block off the area for the grill burners to vent. Adding briquettes can damage ignition components and knobs, and void the warranty.

Keeping the ventilation opening(s) of the cylinder enclosure free and clear from debris.

Never use the grill in extremely windy conditions. If located in a consistently windy area (oceanfront, mountaintop, etc.) a windbreak will be required.

Always adhere to the specified clearance listed on page 6.

NEVER USE A DENTED OR RUSTY PROPANE CYLINDER.

Do not cover grill while still hot.

PLACEMENT OF THE GRILL

MINIMUM CLEARANCE:

2 feet Clearance from both sides of combustible material, and 3 feet Clearance from the back.

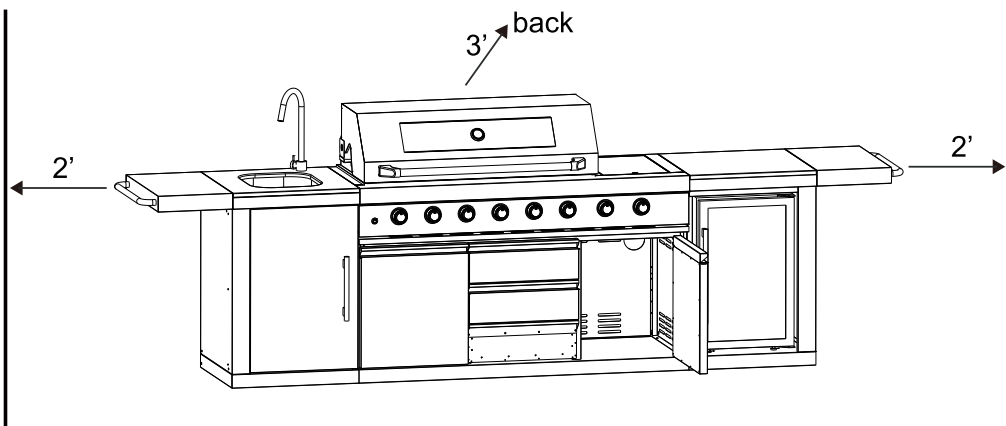

LOCATION







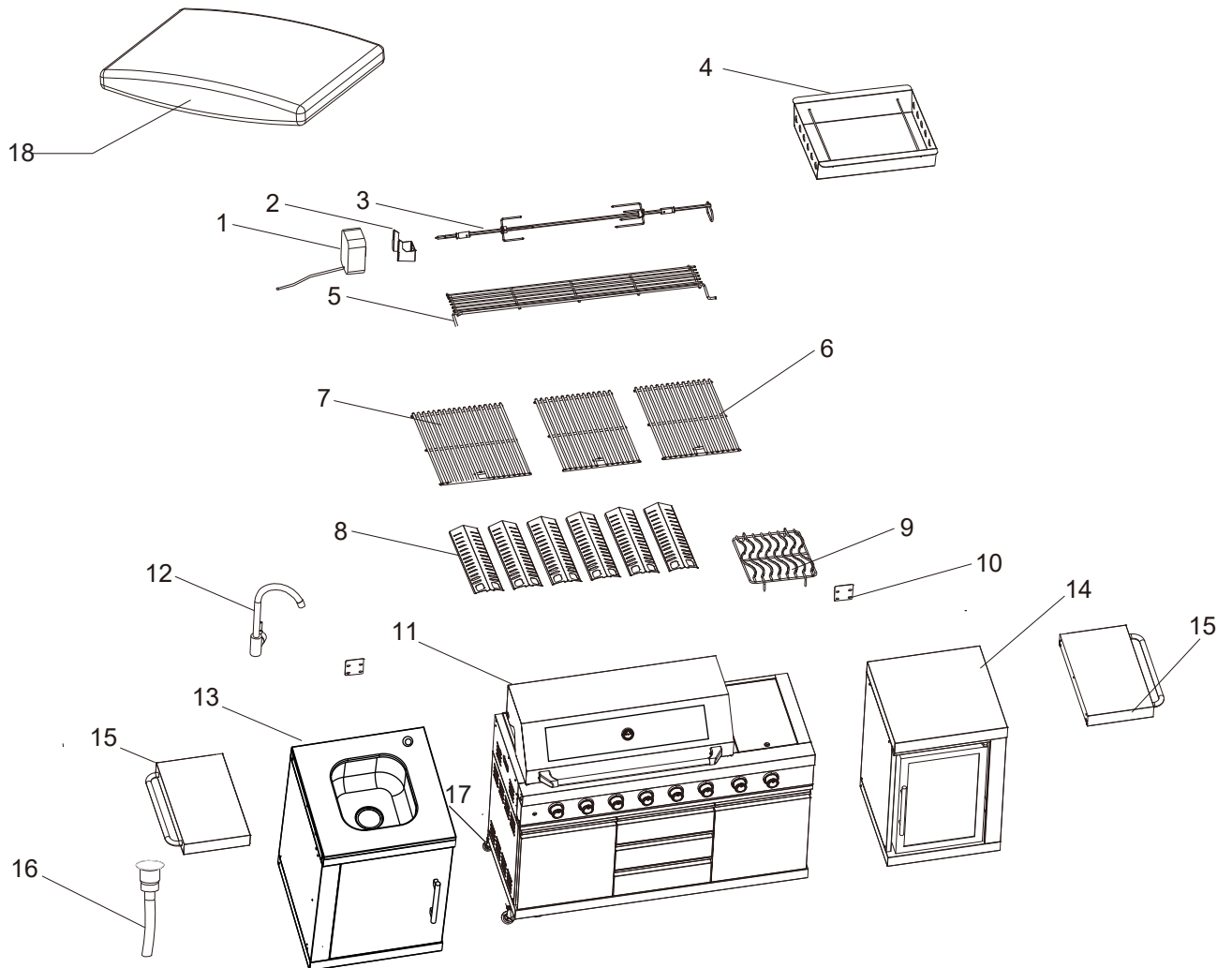

When determining a suitable location take into account concerns such as exposure to wind, proximity to traffic paths and keeping any gas supply lines as short as possible. Locate the grill only in a well-ventilated area. Never locate the grill in a building, garage, breezeway, shed or other such enclosed areas. During heavy use, the grill will produce a lot of smoke. Lock the wheels after the grill is placed in a suitable position.





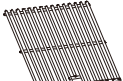
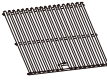

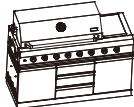

EXPLODED VIEW

Please check the contents of the packaging to ensure all parts are included. If missing parts please contact customer service. Accessories 1、2、3、4、15、18 are optional. Package contents differ by sales channel. Please verify inclusion in your order before purchase.







PART LIST

Part #	Picture	Qty
1	 Motor	1
2	 Motor rack	1
3	 Rotisserie fork	1
4	 Charcoal pan	1
5	 Warming rack	1
6	 Cooking grid A	2
7	 Cooking grid B	1
8	 Heat diffuser	6
9	 Side burner rack	1
10	 Hinge	2

Part #	Picture	Qty
11	 Grill modular	1
12	 Faucet	1
13	 Sink modular	1
14	 Refrigerator modular	1
15	 Handle	2
16	 Drain-pipe	1
17	 Levelling wheel (pre-assembled)	12
18	 Rain Cover	1
<p>Accessories 1、 2、 3、 4、 15、 18 are optional. Package contents differ by sales channel. Please verify inclusion in your order before purchase.</p>		

HARDWARE

Hardware #	Description	Picture	Qty
AA	M6 x 10 Screw		18
BB	M5 x 10 Screw (pre-assembled)		2
CC	M5 Nut (pre-assembled)		2
DD	M6 x 16 Screw (pre-assembled)		10

ASSEMBLY INSTRUCTIONS

Step 1

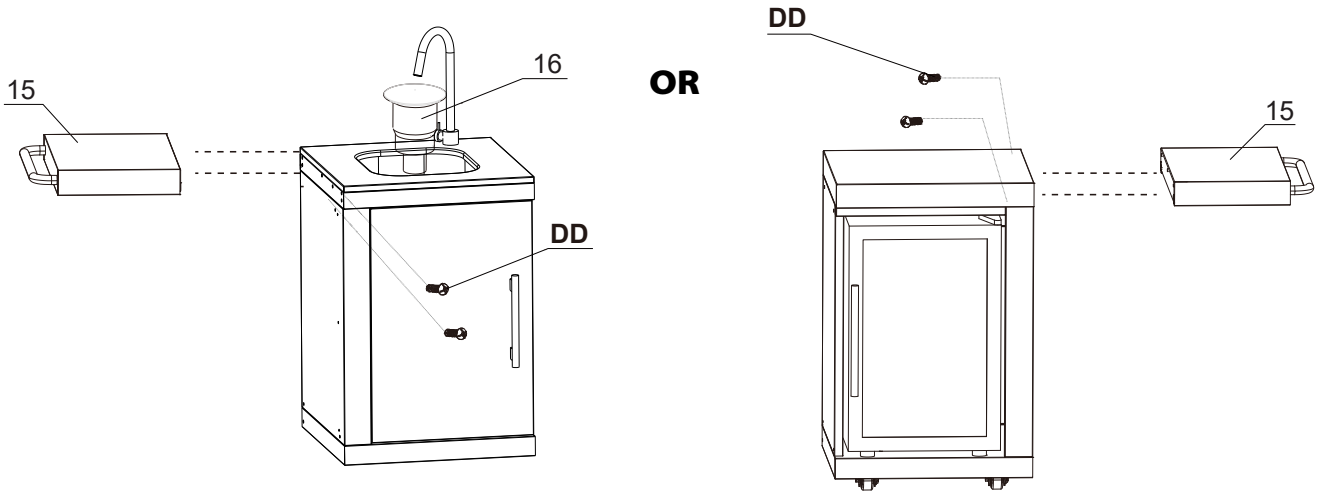

DD x 10 M6x16 (Pre-assembled)

Handle are optional. Package contents differ by sales channel. Please verify inclusion in your order before purchase. It can be installed on either the left or right side of any cabinet.

Step 2

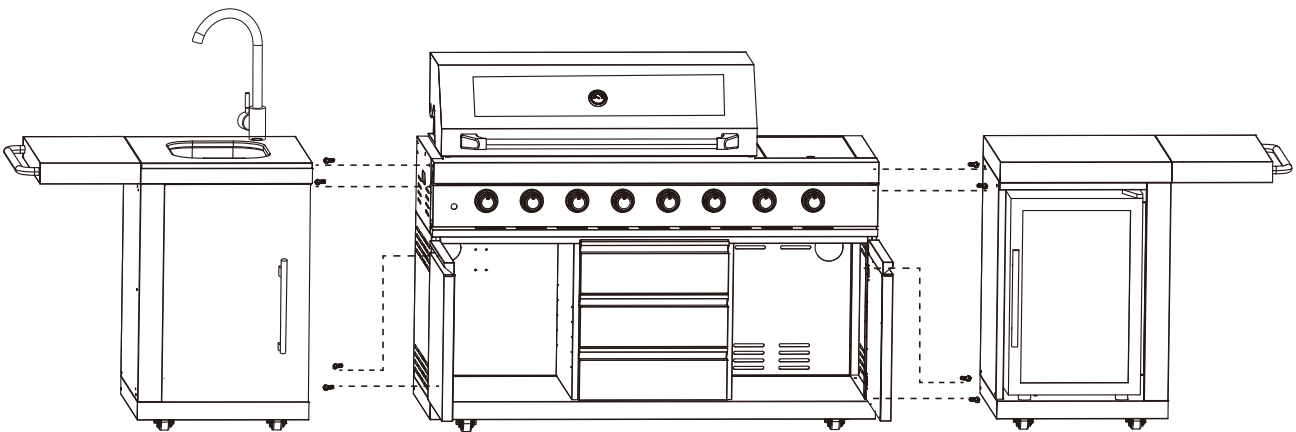

AA x 8 M6x10



ASSEMBLY INSTRUCTIONS

Step 3

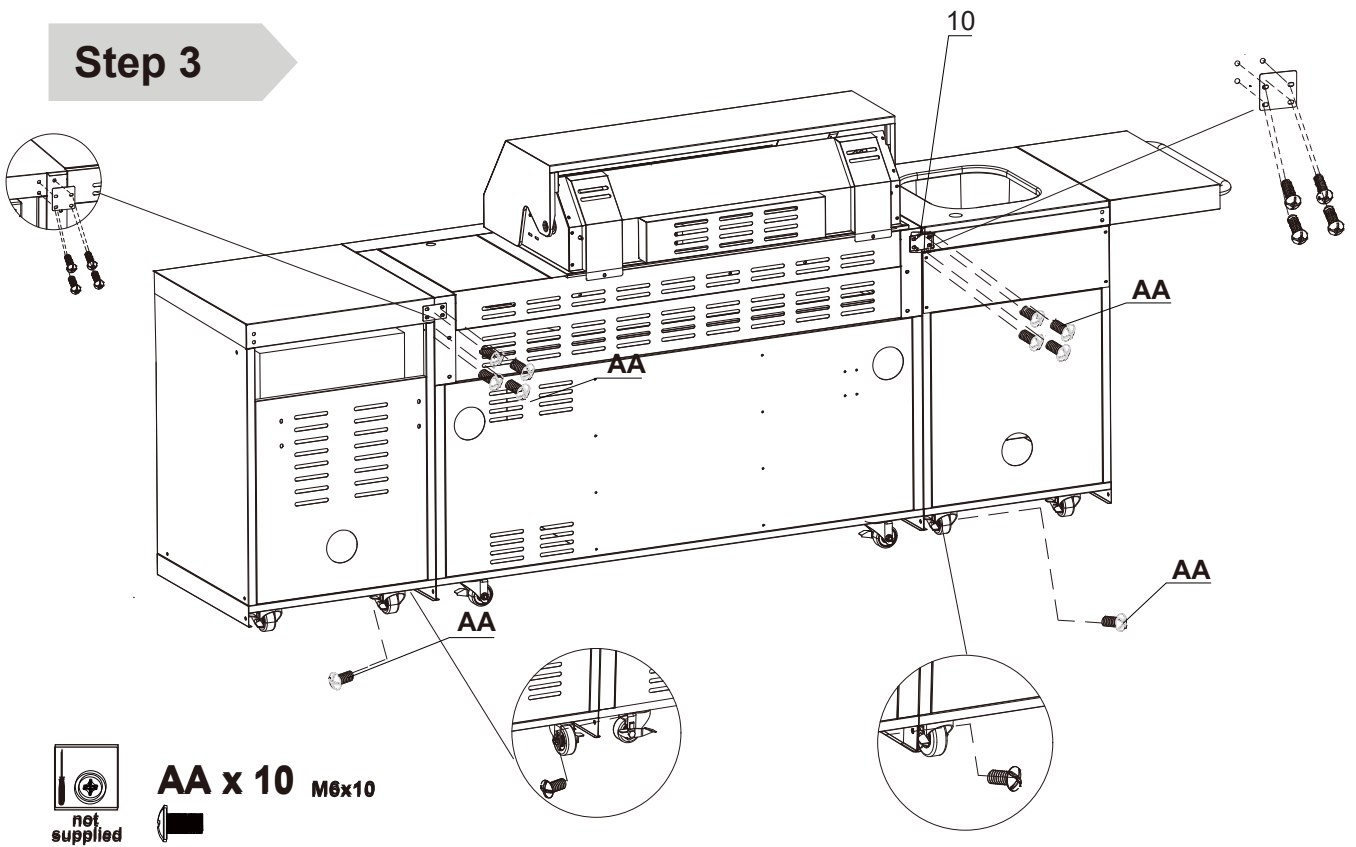

Step 4

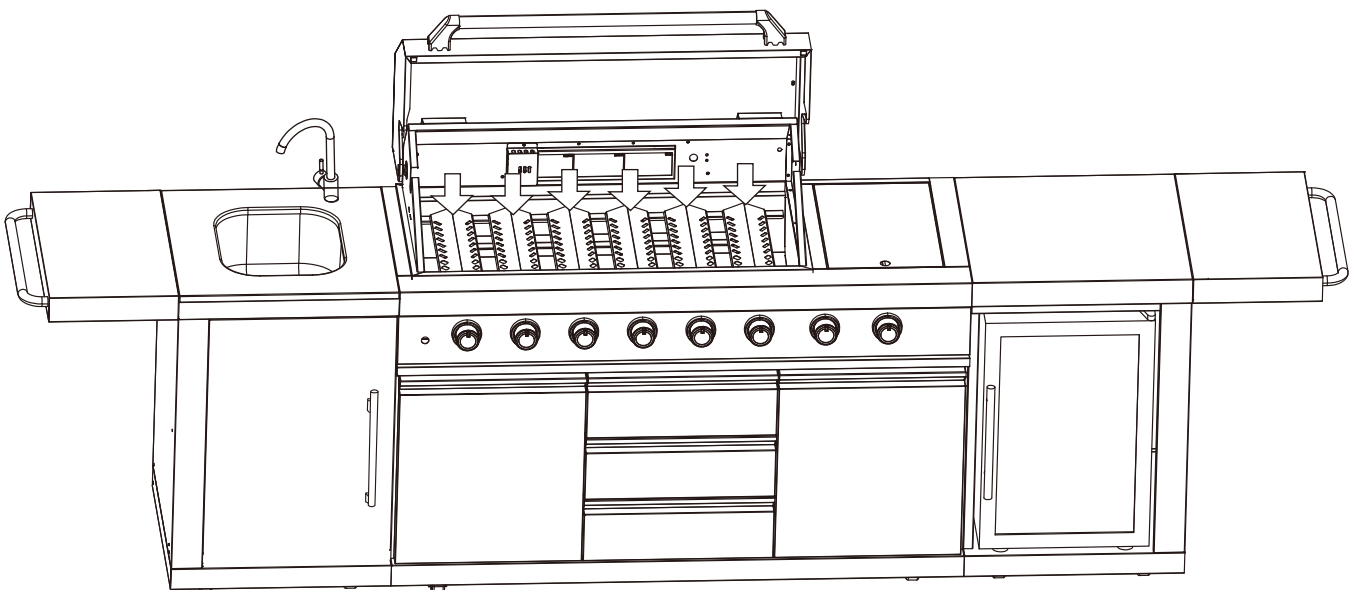

ASSEMBLY INSTRUCTIONS

Step 5

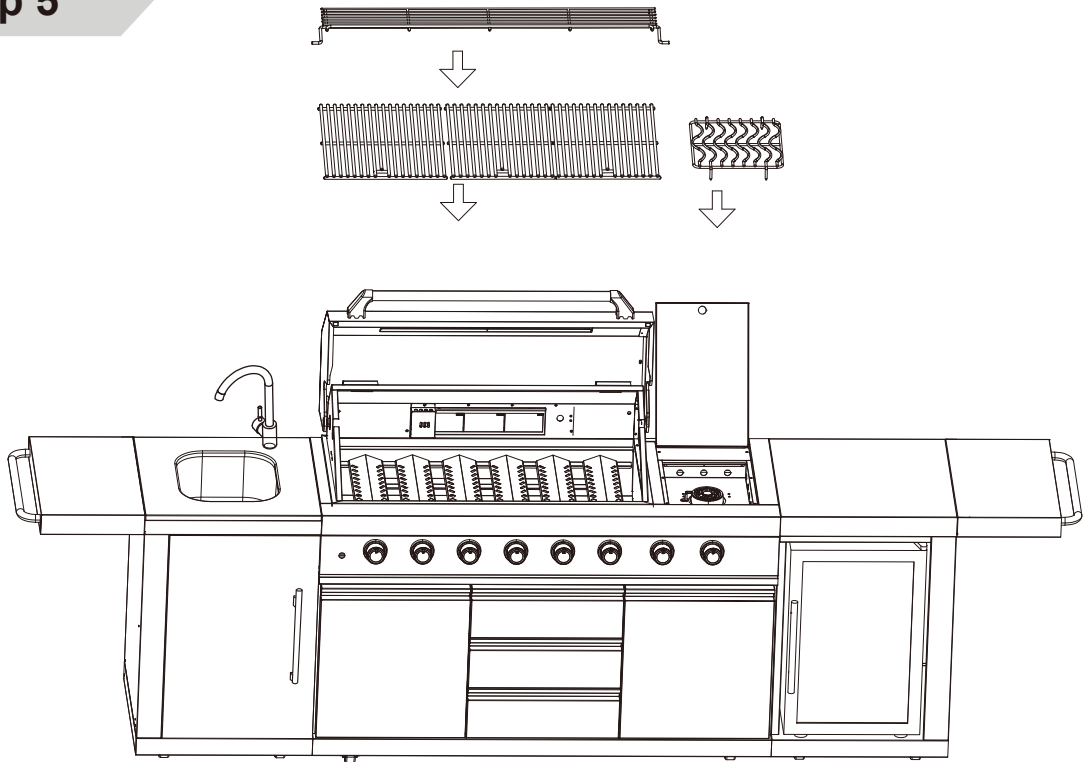

Step 6

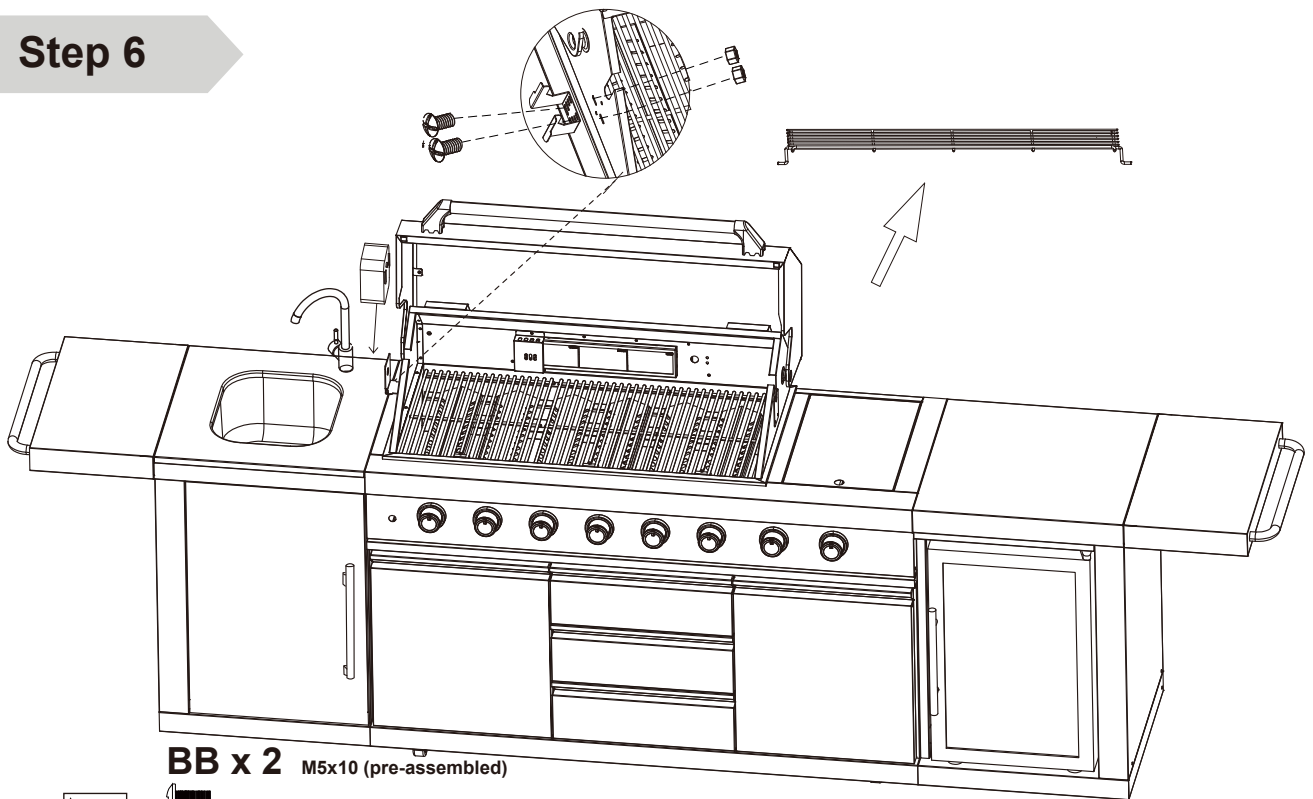

BB x 2 M5x10 (pre-assembled)



CC x 2 M5 Nut (pre-assembled)



not
supplied

ASSEMBLY INSTRUCTIONS

Step 7

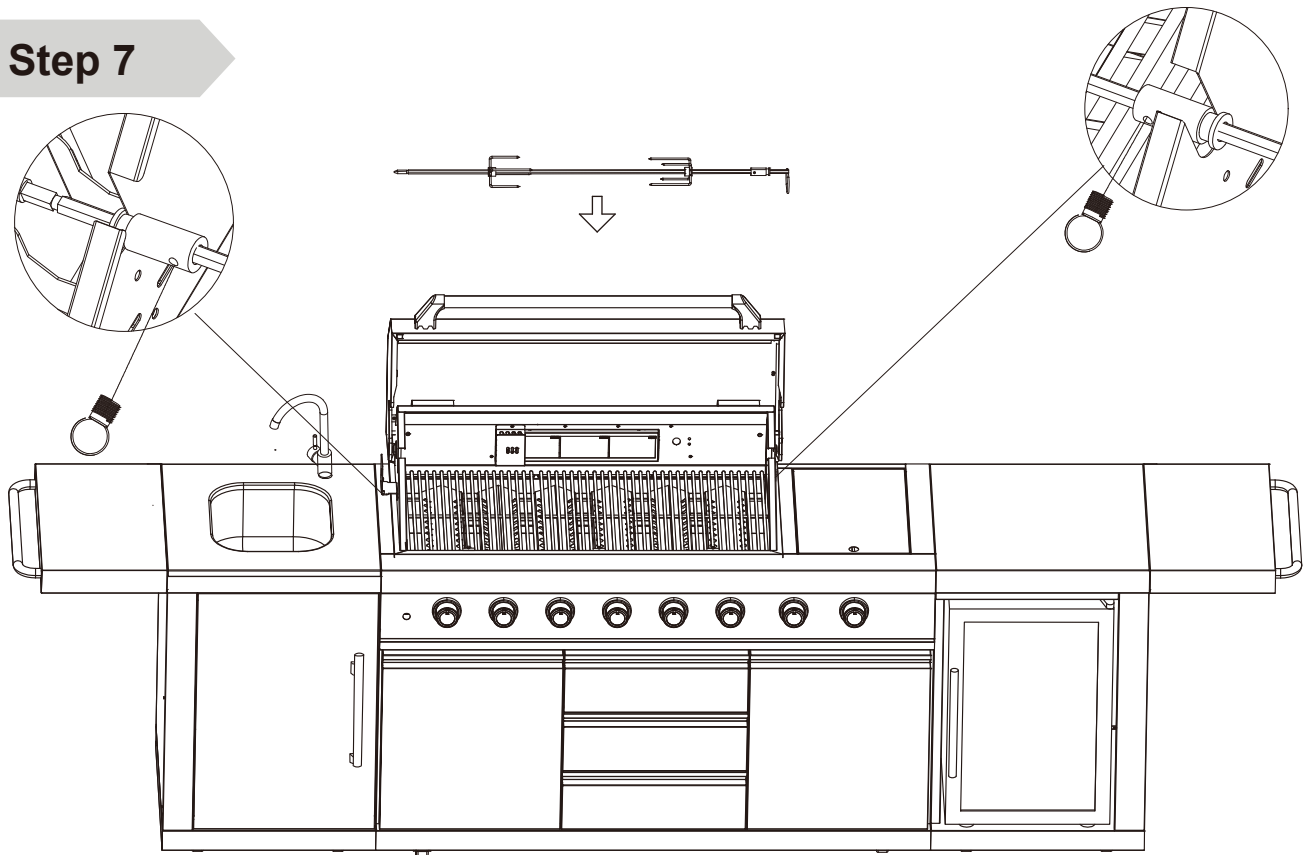

Step 8

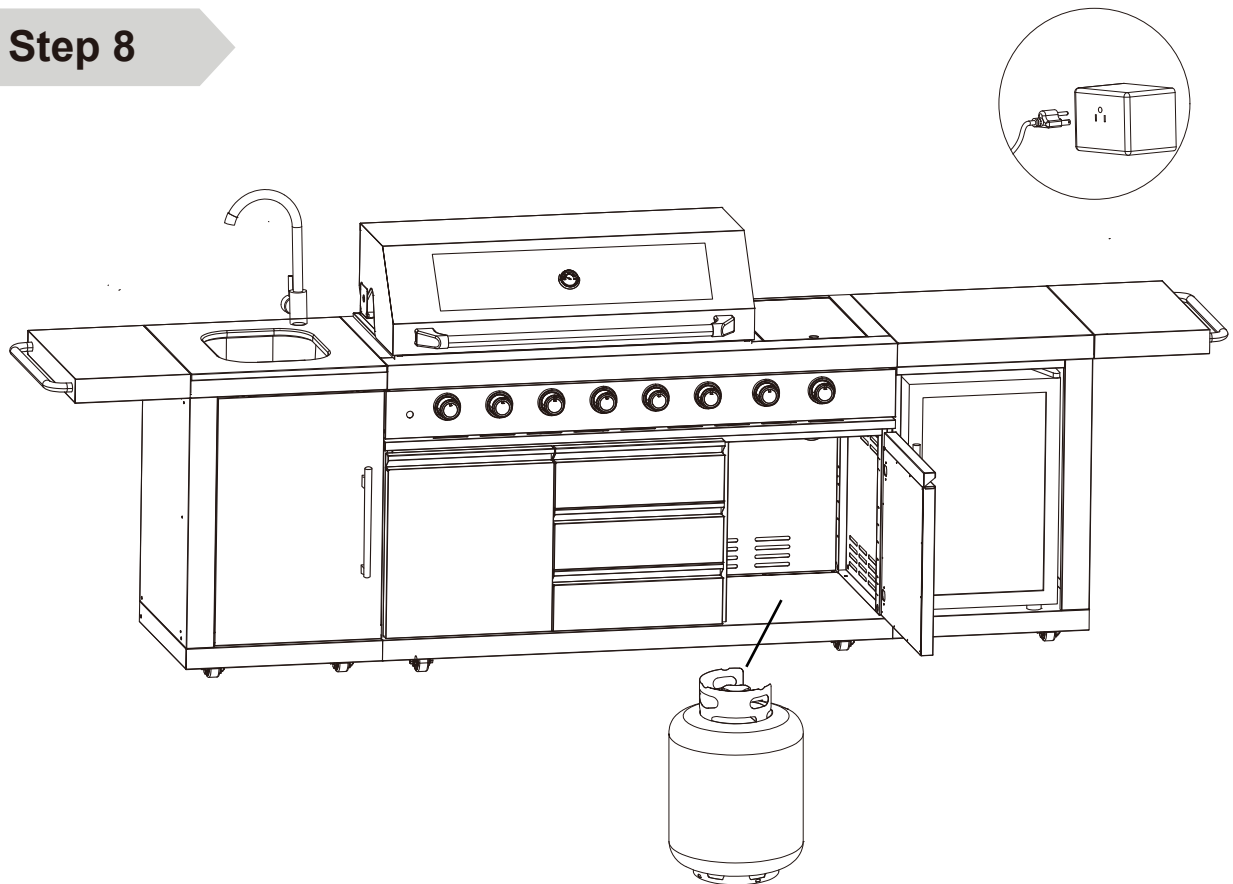

GRILL LIGHTS - OPERATION AND BULB REPLACEMENT

The power supply to the barbecue must be protected by a circuit breaker.

Where the power supply socket is located outdoors it must be rated and approved for outdoor use.

Do not connect the plug to an unprotected extension lead

It is recommended to use a qualified electrician for any power supply installation to the appliance.

When plugged in and switched on the fascia light switch will illuminate

To switch on, push the switch, both the LED lights and control knobs will be illuminated. To switch off push the switch again. Note-Fascia and internal lights are not individually controllable

BULB REPLACEMENT

Only use a 12V 10w G9 Halogen bulb.

Do not touch the Halogen bulb with bare hands.

Oil from your fingertips will reduce the life of the bulb.

Switch off and disconnect the power socket to the barbecue

1. Remove the protective lens. Use a Philips screwdriver and remove the screw securing the oven light housing to the light panel.

2. Taking care not to crack or damage the lens. Gently pull downwards on the lens to remove from its housing.

3. With gloved hand gently pull the old bulb from the light housing and replace with the new bulb

4. Reinstall the lens by snapping it back into the light housing.

5. Use the Philips screwdriver to secure the housing to the light panel.

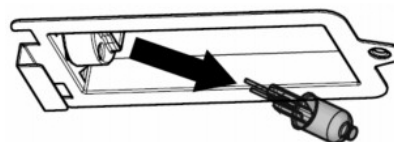
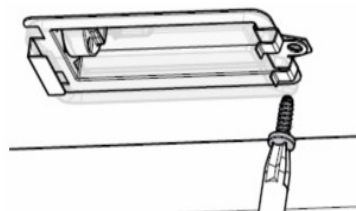
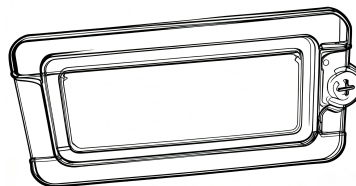

GAS CYLINDER INSTALLATION INSTRUCTIONS

STEP 1

1) Check to ensure that the valve of gas cylinder is securely turned off prior to making the connection. If not, turn the valve clockwise to turn it off.

2) Connect the hose and regulator assembly. Turn the regulator clockwise to make sure it's securely tightened.

Shut off gas supply by rotating valve of gas cylinder clockwise.

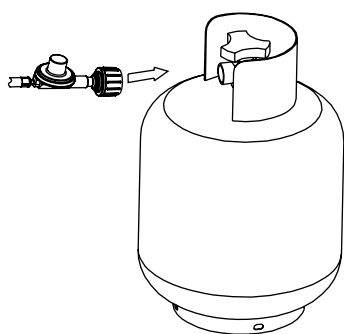

Gas cylinder

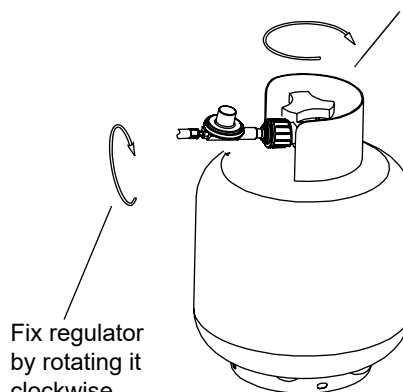

Fix regulator by rotating it clockwise

GAS HOOK-UP

Only the pressure regulator and hose assembly supplied with the grill must be used. Any replacement pressure regulator and hose assembly must be specified by the grill manufacturer.

- This is a liquid propane configured grill.
- Do not connect to a natural gas supply.

Total gas consumption (per hour) of this grill with all burners on "IGNITE/MAX":

Main burner	72,000 Btu/hr
Rear burner	11,600 Btu/hr
Side burner	15,000 Btu/hr
Total	98,600 Btu/hr

The installation of this appliance in Canada must be in accordance with the Standard CAN/CSA-B149.2 (installation code for gas burning appliances and equipment) and local codes.

LP GAS CYLINDER REQUIREMENTS

Use LP cylinders only with these required Maximum Cylinder Size • •
 Propane-306mm (diameter) x 314mm(tall)
 Butane-340mm(H)x240mm(D)

A dented or rusty LP Gas Cylinder may be hazardous and should be checked by your LP supplier. Never use a cylinder with a damaged valve. The LP gas cylinder must be constructed and marked in accordance with the specifications for LP-Gas Cylinders of the U.S. Department

Canada, CAN/CSA-B339, Cylinders, Spheres and Tubes for Transportation of Dangerous Goods, and Commission.

The 20 lb. cylinder must be provided with a shut off valve terminating in an LP gas supply cylinder valve outlet specified, as applicable, for connection type **QCC1** is the standard for compressed gas cylinder valve outlet and inlet connection ANSI/CSA-V-1.

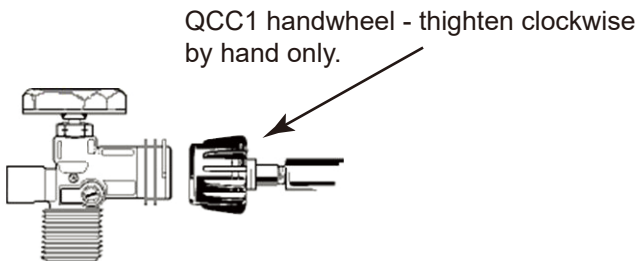

The cylinder supply system must be arranged for vapor withdrawal. The cylinder must include a collar to protect the cylinder valve.

Main Manifold operating pressure: 11" water column (W.C.) /2.74kPa.

LP Gas Cylinder must be fitted with Overfill Prevention Device (OPD).

The OPD is a floater device indicating fill level.

OPD cylinders are identifiable by their triangular valve handle.

The OPD device prevents overfilling. Cylinders must NOT be filled over 80% their capacity.

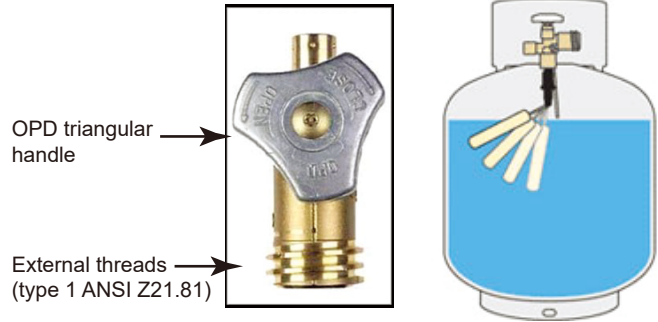

LP GAS HOOK-UP

Ensure that the black plastic grommets (seals) on the LP cylinder valve are in place and that the hose does not come into contact with the hot grease tray or any hot surface.

TO CONNECT THE L.P. GAS SUPPLY CYLINDER

1. Make sure cylinder valve is turned OFF turning clockwise.
2. Check cylinder valve to ensure it has male threads as picture above (type 1 ANSI Z21.81).
3. Make sure all burner valves are in the OFF positions.
4. Inspect valve connections, port and regulator assembly. Look for any damage or debris. Remove any debris. Inspect hose for damage. Never attempt to use damaged or obstructed equipment. See your local LP gas dealer for repair.
5. When connecting hose regulator assembly to the cylinder valve, do so manually, do not use a tool. Tighten firmly clockwise by hand only. The use of a tool will damage the seal and cause a serious risk of gas leak.
6. **SLOWLY** - Open the cylinder valve fully. Proceed to a leak test (see LEAK TESTING section).

of Transportation (D.O.T.) or the National Standard of 2. Check cylinder valve to ensure it has

GAS SAFETY

To disconnect LP gas cylinder:

1. Turn the burner valves off.
 2. Turn the cylinder valve off fully (turn clockwise to stop).
Detach the regulator assembly from the cylinder valve by turning the quick coupling nut counterclockwise.
- Never connect an unregulated LP gas cylinder to your gas grill.
 - Have your LP gas cylinder filled by a reputable propane gas dealer and visually inspected and re-qualified at each filling.
 - Do not store a spare LP gas cylinder under or near this appliance.

If the information above is not followed exactly, a fire or explosion causing death or serious injury may occur.

- Always keep LP gas cylinders in an upright position.
- Do not store or use gasoline or other flammable vapors and liquids in the vicinity of this gas grill.
- Do not subject the LP gas cylinder to excessive heat.
- Never store an LP gas cylinder indoors. Storage of an outdoor cooking gas appliance indoors is permissible only if the cylinder is disconnected and removed from the outdoor cooking gas appliance. Cylinders must be stored outdoors out of the reach of children and must not be stored in a building, garage, or any other enclosed area.
- Place dust cap on cylinder valve outlet whenever the cylinder is not in use. Only install the type of dust cap on the cylinder valve outlet that is provided with the cylinder valve. Other types of caps or plugs may result in leakage of propane.
- If the outdoor cooking gas appliance is not in use, the gas must be turned off at the supply cylinder.
- The regulator and hose assembly must be inspected before each use of the grill. If there is excessive abrasion or wear or if the hose is cut, it must be replaced prior to the grill being lit again.
- Keep the gas regulator hose away from hot grill surfaces and dripping grease. Avoid unnecessary twisting of hose.
- Never light your gas grill with the lid closed or before checking to ensure the burner tubes are fully seated over the gas valve orifices.
- Never allow children to operate your grill.

Approved LPG hose and regulator: GR-129A

QCC-1 QUICK CLOSING COUPLING

This appliance is designed to be used with an LP gas cylinder equipped with the QCC-1 Type 1 Quick Closing Coupling system which incorporates new safety features required by the American National Standard Institute (ANSI).

- Gas will not flow until a positive connection has been made.
- A thermal element with shut off the flow of gas between 240 °F. and 300 °F.
- When activated, a flow limiting device will limit the flow of gas.

Purchase a gas cylinder equipped with a QCC valve. The QCC valve is recognizable by the external threads on the inlet of the valve.

GAS HOSE AND REGULATOR

Your gas grill comes equipped with a hose and regulator with a QCC-1 Quick Closing Coupling to gas tank. The replacement hose assembly shall be that specified by the manufacturer.

CAUTION WHEN OPENING CYLINDER VALVE

The QCC coupling contains a magnetic Flow Limiting Device which will limit the flow of gas should there be a leak between the regulator and the grill valves (overpressure). This device will activate if the cylinder valve is opened while the grill valves (control knobs) are open. **ENSURE GRILL VALVES (KNOBS) ARE TURNED OFF BEFORE YOU OPEN CYLINDER VALVE** to prevent accidental activation thus, limiting gas flow making it impossible to ignite grill.

ALWAYS OPEN SLOWLY THE CYLINDER VALVE.

WARNING

A strong gas smell or the hissing sound of gas indicates a serious problem with your gas grill or the LP gas cylinder. Failure to immediately follow the steps listed below could result in a fire or explosion that could cause serious bodily injury, death, or property damage.

- * Shut off gas supply to the gas grill.
- * Turn the control knobs to OFF position.
- * Put out any flame with a proper fire extinguisher.
- * Open grill lid.
- * Get away from the LP gas cylinder.
- * Do not try to fix the problem yourself.

If odor continues or you have a fire you can not extinguish, call your fire department. Do not call from near the LP gas cylinder because your telephone is a form of electrical device and could create a spark resulting in fire and/or explosion.

LEAK TESTING

GENERAL

Although all gas connections on the grill are leak tested at the factory prior to shipment, a complete gas tightness check must be performed at the installation site due to possible mishandling in shipment, or excessive pressure unknowingly being applied to the unit. Periodically check the whole system for leaks following the procedures listed below. If the smell of gas is detected at any time, you should immediately check the entire system for leaks.

BEFORE TESTING

Make sure that all packing material is removed from the grill including the burner tie-down straps.

DO NOT SMOKE WHILE LEAK TESTING.

NEVER LEAK TEST WITH AN OPEN FLAME.

Make a soap solution of one part liquid detergent and one part water. You will need a spray bottle, brush, or rag to apply the solution to the fittings. For the initial leak test, make sure the L.P. cylinder is full.

TO TEST

Make sure all control valves are in the "OFF" position. Turn the gas supply on. Check all connections from the L.P. cylinder up to and including the connection to the manifold pipe assembly (the pipe that goes to the burners). Use the soap solution and spray or brush it onto all of these connections.

Soap bubbles will appear where a leak is present. If a leak is present, immediately turn off the gas supply, tighten any leaking fittings, turn gas on, and recheck. Should the gas continue to leak from any or all of the fittings, turn off the gas supply, and contact our customer service.

Only those parts recommended by the manufacturer should be used on the grill. Substitution will void the warranty. Do not use the grill until all connections have been checked and do not leak.

GAS FLOW CHECK

Each grill burner is tested and adjusted at the factory prior to shipment; however, variations in the local gas supply may make it necessary to adjust the burners, the flames of the burners should be visually checked.

Flames should be blue and stable with no yellow tips, excessive noise or lifting. If any of these conditions exist, check to see if the air shutter or burner ports are blocked by dirt, debris, spider webs, etc. If you have any questions regarding flame stability, please call customer service .

ALWAYS CHECK FOR LEAKS AFTER EVERY LP CYLINDER CHANGE

Check all gas supply fittings for leaks before each use. It is handy to keep a spray bottle of soapy water near the shut-off valve of the gas supply line. Spray all the fittings. Bubbles indicate leaks.

Disconnected L.P. cylinders must have threaded valve plugs tightly installed, and must not be stored in a building, garage or any other enclosed area.

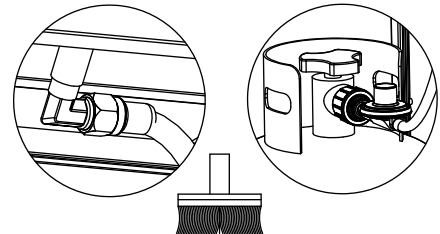

LIGHTING INSTRUCTIONS

WARNING: IMPORTANT!

BEFORE LIGHTING...

Inspect the gas supply hose prior to turning the gas "ON". If it is evident there is excessive abrasion or wear, or the hose is cut, it must be replaced prior to the grill being put into operation. The replacement pressure regulator and hose assembly shall be that specified by the manufacturer. Do not use the grill if the odor of gas is present. Only the pressure regulator and hose assembly supplied with the unit should be used. Never substitute regulators for those supplied with the grill. If a replacement is necessary, contact the factory for proper replacement.

Screw the regulator (type QCC1) onto the cylinder. Leak check the hose and regulator connections with a soap and water solution before operating the grill, [see leak testing section](#).

MAIN BURNER'S LIGHTING INSTRUCTIONS:

Always keep your face and body as far from the grill as possible when lighting.

1. Read the instructions before using the appliance.
2. Open lid during lighting.
3. Ensure knobs are in "off" position.
4. Connect regulator with cylinder, then turn on.
5. Push and turn control knob counter-clockwise to "max" position until click is heard and burner is lit. Then release knob. Adjust the flame by turning control knob between "max" and "min" positions.
6. If ignition does not occur in 5 seconds, turn the burner control off, wait 5 minutes, and repeat the lighting procedure.
7. To turn off, turn control knob clockwise until it locks in "off" position.

REAR BURNER'S LIGHTING INSTRUCTIONS:

1. Push and turn control knob to "ON" position, continue pushing knob while pressing "REAR/SIDE BURNER IGNITER" button for 2 to 5 seconds.
2. When burner is lit, release the knob and igniter.
3. If ignition does not occur in 5 seconds, turn the knob to "OFF" position, wait 5 minutes, and repeat step 1.

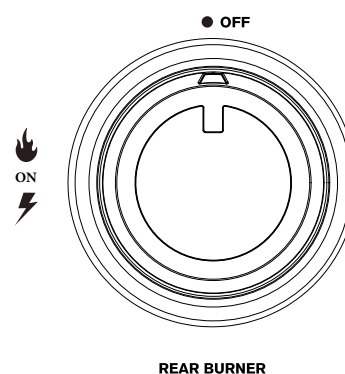
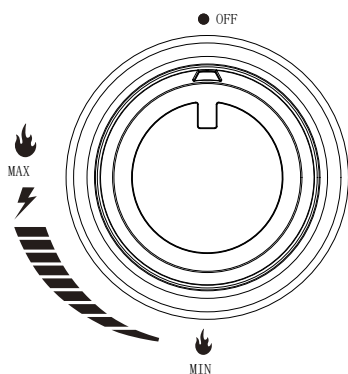

LIGHTING INSTRUCTIONS

ROTISSERIE OPERATING INSTRUCTIONS

Important:

Your grill may be equipped with rotisserie burner. The instructions below include operation for grills equipped with a rotisserie burner and instructions for grills not equipped with rotisserie burners. Be sure to follow the instructions appropriate for your grill.

Important safety Instructions Caution:

WARNING

Electrical Grounding Instructions

This outdoor cooking gas appliance is equipped with a three-prong (grounding) plug for your protection against shock hazard and should be plugged directly into a properly grounded three-prong receptacle. Do not cut or remove the grounding prong from this plug.

Please read the following safety precautions before using the rotisserie motor.

1. Read all instructions before assembly, installation and use.
2. Do not touch hot surface with bare hands.
3. To protect against electrical shock, do not immerse cord, plug, or motor in water or other liquid.
4. Close supervision is necessary when any appliance is used by or near children.
5. Unplug from outlet when not in use and before cleaning. Allow to cool before putting on or taking off parts. Do not clean this product with a water spray or the like.
6. Do not operate any appliance with a damaged cord or plug or after the appliance has been damaged in any manner. Contact the manufacturer for repair.
7. The use of other accessory attachments is not recommended by the appliance manufacturer as it may cause injuries.
8. Do not let the electric cord touch hot surfaces or hang over the edge of a table or counter.
9. Do not power cord on or near a hot gas or electrical burner, or in a heated oven.
10. Caution must be used when assembling. The pointed end of a spit rod and the meat forks as the ends are sharp.

CAUTION: REMOVE THE WARMING RACK WHEN USING THE ROTISSERIE BURNER. THE HIGH HEAT COMING FROM THE BURNER MAY CAUSE THE WARMING RACK TO BEND.

11. Always attach power cord to appliance first, then plug cord into the wall outlet. If the plug does not fit in the outlet, contact a qualified electrician. DO NOT attempt to modify the plug or override this safety feature. Use only a ground fault interrupter (GFI) protected circuit with this outdoor cook gas appliance. Never remove the grounding plug or use with an adapter with 2 prongs. Use only extension cords with a 3-prong grounding plug, rated for the power and approved for outdoor use with a "UL-Listed" marking.
12. Do not use this appliance other than for the intended use.
13. Wood fuel, and/or charcoal briquettes are not to be used with this appliance.
14. Do not expose to rain.
15. To ensure continued protection against risk of electrical shock, connect to properly grounded outlets only.
16. A short power supply cord is provided to reduce the risk of becoming entangled in or tripping over a longer cord.
17. Longer detachable power-supply cords or extension cords may be used if care is exercised in their use.
18. If longer detachable power-supply cords or extension cord is used, the marked electrical rating of the cord set or extension cord should be at least as great as the electrical rating of the appliance and the cord should be arranged so that it will not drape over the countertop or tabletop where it can be pulled on by children or tripped over.
19. To reduce the risk of electrical shock, keep extension cord connection dry and off the ground.
20. Store indoors when not in use – out of the reach of children.
21. Always follow the directions provided with your rotisserie as each unit differs in design and capabilities.
22. Always follow all safety procedures as stated in your rotisserie and grill manual.
23. To avoid injury, let the grill cool down before removing the drip pan. Save these operation instructions for rotisserie use on a grill equipped with rotisserie burners:

IMPORTANT: IF YOUR GRILL IS EQUIPPED WITH A ROTISSERIE BURNER, ONLY THAT BURNER SHOULD BE USED FOR COOKING WHEN THE ROTISSERIE IS MOUNTED AND IN OPERATION. THE MAIN BURNERS ON THE GRILL MUST BE TURNED TO THE OFF POSITION WHEN THE ROTISSERIE BURNER IS IN USE.

LIGHTING INSTRUCTIONS

ROTISSERIE OPERATING INSTRUCTIONS

IMPORTANT: Do not use the rotisserie burner and the main burner at the same time.

Do not use side burner when the rotisserie is in use to prevent burns.

1. Slide one of the meat prongs onto the rod (prongs toward the food). Center the food on the rod, then secure with the other meat prongs. Then push the meat forks firmly together. Tighten the thumbscrews. It may also be necessary to wrap food with butcher's string, (never use nylon or plastic string) to secure loose portions.
2. Once the food is secure, insert the pointed end of the rotisserie rod into the motor assembly and rest the other end on the support on the right-hand side of the grill.
3. Check for clearance with the cooking grates. The grates can be removed if additional clearance is required. **IMPORTANT:** If grates are removed, make sure food is not touching the burner(s).
4. Place a shallow drip pan underneath the food to catch drippings and make for easier cleanup.
5. Plug the unit into an electrical outlet. Turn the power switch to the ON position to start the rotisserie motor. To begin, turn burners onto the lowest setting.
6. Check for constant speed of the rotisserie rod. If the rod does not turn at a constant speed, reposition the food on the forks. An unbalanced rotisserie rod will damage the motor.
7. Check food frequently and adjust burner temperature based on observations. This will require some experimentation as each grill has different heating and cooking characteristics

Trouble shooting

If the rod is not rotating at a constant speed, reposition the meat on the forks.

SIDE BURNER'S LIGHTING INSTRUCTIONS

Inspect the gas supply hose prior to turning the gas "ON". If there is evidence of cuts, wear or abrasion, it must be replaced prior to use. Do not use the side burner if the odor of gas is present.

WARNING: Always keep your face and body as far away from the burner as possible when lighting.

1. Read instructions before lighting.
2. Open lid during lighting.
3. Ensure the knob is in "OFF" position.
4. Turn on the cylinder valve.
5. Push and turn control knob to "MAX" position, continue pushing knob while pressing "REAR/SIDE BURNER IGNITER" button for 2 to 5 seconds.
6. Release the knob, adjust the flame by turning the knob between "Max" and "MIN" position.
7. If ignition does not occur in 5 seconds, turn the burner control off, wait 5 minutes, and repeat the lighting procedure.

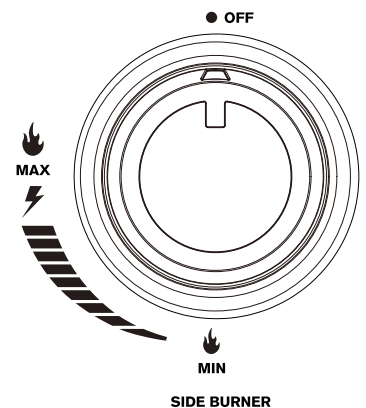

LIGHTING INSTRUCTIONS

Charcoal pan instructions

- Do not apply oil to charcoal pan.
- Check to make sure the air vents are free of debris and ash before using.
- Before each use, check for any damaged or loose parts. Tighten any loose parts and replace any damaged parts before using.
- Make sure charcoal pan is empty and securely and completely in place before using.

1. Open lid, remove warming rack(#5), rotisserie fork (#3) (if installed), 2pcs of cooking grids (#6&7) and 3pcs of heat diffuser (#8), set aside, then put the charcoal pan(#4) into the grill body.
2. Make sure charcoal pan is empty and secure.
3. For grilling or smoking, start with approximately 7.0lbs/3.1kgs. Colder climates may require more charcoal. **DO NOT FILL PAST THE TOP OF THE CHARCOAL PAN.**
4. Light per instructions on fuel package.
5. While wearing heat resistant gloves, carefully spread hot coals evenly around the charcoal pan with a long-handled
6. tool. Allow fuel to burn into glowing coals before cooking.
7. While wearing protective gloves place cooking grates on the grill body, place lid and allow grill to preheat.
8. While wearing protective gloves open lid and place food onto cooking grate above the hot coals with long-handled tongs.

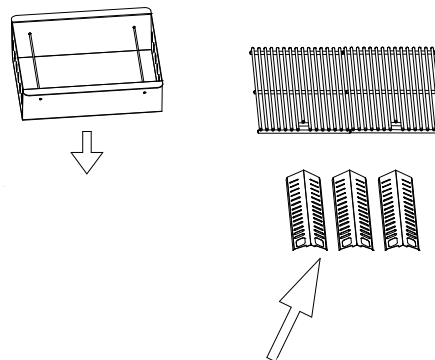

TIP: Wood chips may be used with charcoal, during the cooking process.

Prior to adding wood chips, allow the charcoal to burn until covered with a light ash. To add wood chips before cooking, wrap the desired amount of wood chips in aluminum foil and place directly onto the charcoal. Poke holes on the top of the foil wrapping to allow smoke to escape. Wood chips can also be placed directly onto the charcoal without aluminum foil, but the height of the wood chips should not exceed the height of the charcoal pan. If the fuel level is too high, wearing the gloves, use metal tongs to spread the top layer of fuel evenly across the charcoal pan. The amount and type of wood you use is entirely dependent on the desired amount of flavor. Always follow the instructions on the flavored wood packaging prior to use.

⚠ Caution

- Allow charcoal to burn out by closing the holds of pan. Except in the case of an emergency, do NOT pour water on hot coals.
- Wearing heat resistant gloves during operating.
- Always wear heat resistant gloves when adding fuel (charcoal briquettes, wood or lump charcoal) to retain desired heat level.
- Never use charcoal that has been pre-treated with lighter fluid. Use only a high-grade plain charcoal, charcoal/wood mixture, lump charcoal or cooking wood,
- Open lid slowly as flare-up can occur when fresh air suddenly comes in contact with fire.
- Never add lighting fluid to hot or even warm coals as flashback may occur causing serious injury or damage to property.

LIGHTING INSTRUCTIONS

TO MATCH LIGHT THE GRILL

If the burner will not light after several attempts then the burner can be match lit.

1. Open lid before lighting.
2. Turn the burner control knobs to "OFF".
3. Place a paper match in the end of the match lighter. Strike the match and place through the cooking grate to the LEFT burner, 1 /2" (1 to 2 cm) away.
4. Turn on the LEFT burner control knob to "MAX" position. The burner should light within 5 seconds.
5. If the burner does not light, turn the control knob to "OFF" and wait 5 minutes for gas to dissipate and repeat lighting procedure.
6. Once lit, light adjacent burners in sequence by pressing in and rotating the control knob to the "MAX" position.
7. If the burner does not light within the first few attempts of match lighting, there is a problem with the gas supply. Turn off the gas at the burner and cylinder. DO NOT attempt to operate the grill until the problem is found and corrected. See "Trouble Shooting" section of this manual .

GRILLING GUIDE

Outdoor grilling is really quite simple. You'll succeed with burgers, dogs, or steaks usually on your very first try. With experience, you will learn how to work with your grill, creating more imaginative meals all the time. This knowledge makes up the art of grilling. Before you start grilling, organize your food according to cooking technique and required cooking time, and optimize the use of your grilling area.

PREHEATING

Preheat your barbecue on MED/HIGH with the lid closed for ten minutes. Adjust heat for what you will be grilling. Scrub grids with a wire brush and apply cooking oil to reduce food from sticking.

LID POSITION

Lid position is a matter of preference. Grilling with the lid closed will cook faster, use less gas and will control the temperature better. It will also give a smokier taste to foods with the lid closed.

DIRECT COOKING

Direct cooking involves grilling your meat directly over high heat. It is perfect for searing steaks, chops, and other smaller pieces of meat and vegetables that quickly make their way to the table.



INDIRECT COOKING

Indirect cooking utilizes select burners to circulate heat throughout the grill, without direct contact between the meat and the flame. The meat is placed over the burner that is 'off'. This method is generally used to slow cook large cuts of meat and poultry. A pan can be placed underneath the meat to catch grease and food drippings, and helps minimize clean-up.



GRILLING GUIDE

USING THE GRILL

Grilling requires high heat for searing and proper browning. Most foods are cooked at the "MAX" heat setting for the entire cooking time. However, when grilling large pieces of meat or poultry, it may be necessary to turn the heat to a lower setting after the initial browning. This cooks the food through without burning the outside. Foods cooked for a long time or foods basted with a sugary marinade may need a lower heat setting near the end of the cooking time.

TO BEGIN

1. Make sure the grill has been leak tested and is properly located.
2. Remove any remaining packing material.
3. Light the grill burners using the instructions.
4. Turn the control knob(s) to "MAX" and preheat the grill for 15 minutes. The grill lid is to be closed during the appliance preheat period.
5. Place the food on the grill and cook to the desired doneness. Adjust heat setting, if necessary. The control knob may be set to any position between "MAX" and "MIN".

NOTE: The grill is designed to grill efficiently without the use of lava rocks or briquettes of any kind. Heat is radiated by the flame tamers positioned above each burner.

⚠ Caution: After using the "MAX" fire setting for 10 minutes, if you need to close the lid and use it, no more than 3 burners can be used on the "MIN" fire setting at this time.

DO NOT LEAVE THE GRILL UNATTENDED WHILE COOKING.

Cooking Tips:

- To prevent foods from sticking to the grill it is essential to coat the grill with oil. Then light up the burners on high for 3-5 mins to warm up the barbecue.
- Constant turning over of the meats can cause loss of juices as juices tend to rise to the tops of the meat, avoid excess turning of the meats to keep them succulent and juicy.
- Basting the foods whilst cooking with marinade or oil to seal in the flavor, avoid excessive basting as this may cause flare-up.
- To ensure safe consumption of frozen meats and poultry, they should be defrosted in the refrigerator before cooking.
- As an alternative to simply grilling, you can marinate your meat, fish, poultry or vegetables first, this will ensure the flavors are locked in. it recommended to allow the meats to stand in a refrigerator whilst in the thawing process.
- Avoid charring or burning of the foods with direct flames as this may not be healthy. Do not leave cooked foods standing for too long before consumption.
- When cooking a roast, it is a good idea to use a roast holder and baking dish. Always use a baking dish with a depth greater than 35mm. shallower trays may fill quickly and overflow, which may cause a fat fire.
- The hot grill sears the food, sealing in the juices. The longer the preheat lasts, the faster the meat browns and the darker the grill marks.

CARE & MAINTENANCE

CAUTION:

All cleaning and maintenance should be done when grill is cool and with the gas supply turned off at the propane cylinder.

DO NOT clean any grill part in a self cleaning oven. The extreme heat will damage the finish.

CLEANING

Burning-off the grill after every use (approx. 15 minutes) will keep excessive food residue from building up.

STAINLESS STEEL SURFACE

Under extreme conditions, stainless steel can rust and the rust may not be removable. These conditions may become more prevalent in coastal areas. Always use extra precautions while cleaning the stainless steel using a soft non-abrasive cloth and a stainless steel cleaner/polish to minimize the risk of scratching the surface.

PAINTED SURFACES

Wash with mild detergent or nonabrasive cleaner and warm soapy water. Wipe dry with a soft nonabrasive cloth.

COOKING SURFACES

If a bristle brush is used to clean any of the grill cooking surfaces, ensure no loose bristles remain on cooking surfaces prior to grilling. It is not recommended to clean cooking surfaces while grill is hot.

BURNERS

Ensure the gas supply is off and the knobs are in the "OFF" position. Make sure the grill is cool. Clean the exterior of the burner with a wire brass brush. Clear stubborn scale with a metal scraper. Clear any clogged ports with a straightened paper clip. Never use a wooden toothpick as it may break off and clog the port.

At beginning of season and the frequency depending of your area, clean burner venturi tubes with a flexible spring shaft cleaning brush. Insects and spiders have a tendency to nest in venturi tubes and block flow of gas, see "To inspect and clean venturi tubes" in this page.

GREASE TRAY CLEANING

The grease tray should be emptied and wiped down periodically and washed in a mild detergent and warm water solution. A small amount of sand or cat litter may be placed in bottom of grease tray to absorb the grease. Check the grease tray frequently, don't allow excess grease to accumulate and overflow out of the grease tray.

CONTROL PANEL GRAPHICS

To avoid damage to control panel graphics, do not use steel wool, abrasive cleaners or oven cleaner. Do not spray cleaner directly onto panel.

Wash with mild detergent and warm water. Wipe dry with a soft cloth. Clean around the burner labels gently; scrubbing may remove printing.

Check your grill for the following items every six months

1. Make sure the area around the grill free and clear of combustible materials.
2. Make sure the combustion and ventilation openings are not obstructed.
3. Make sure the ventilation openings of the cart are not obstructed.
4. Visually check the burner flames.
5. Clean your grill as described above.

To inspect and clean venturi tubes

1. Make sure gas is turned off at cylinder.
2. Wait until grill is cool.
3. Unfasten screw (A) at rear of tubular burner. Notice the gas port holes (B) running across top of burner close to front. When reinstalling, they must be facing upwards. Slide out burner toward rear.
4. Clean through with a flexible spring shaft cleaning venturi brush.
5. Slide back burner tube into housing, ensure burner inlet is aligned and fitted over the valve orifice.
6. Secure burner with screw at rear.

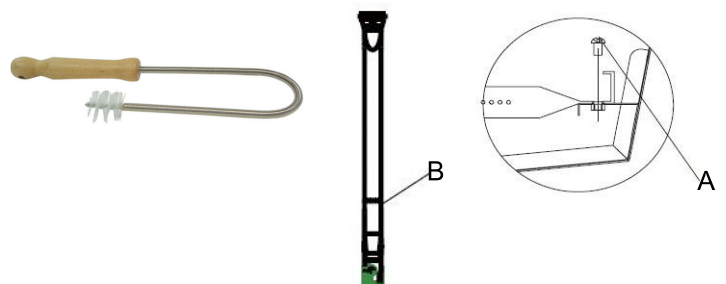

TROUBLE SHOOTING

BEFORE CALLING FOR SERVICE

If the grill does not function properly, use the following checklist before contacting your dealer for service. You may save the cost of a service call.

PROBLEM	SOLUTION
When light the grill, it does not ignite immediately.	<ul style="list-style-type: none"> -- Make sure you have turned on the gas. -- Make sure it has a spark while you are trying to ignite the burner. -- Push in control knob and turn to ignite/preheat and hold for approximately 5 seconds and then ignite the grill. -- Make sure your burner is clean.
Regulator makes noise.	<ul style="list-style-type: none"> -- Vent hose on the regulator may be plugged or regulator may be faulty. -- Make sure the vent hole on the regulator is not obstructed. Clear the hole, close the LP cylinder and gas control valves. Wait 10 minutes and re-start. -- When turning the LP cylinder valve on, do not cover vent hole on the regulator. -- Check your flames for proper performance. Replace regulator if the flames are not correct. -- Purge The lines.
Grill only heats to 200-300 °F	<ul style="list-style-type: none"> -- Ensure the temperature gauge is functioning properly. Hold a flame to the probe or compare the grill gauge to an oven thermometer placed in the grill. -- Ensure correct start procedure. Prior to lighting grill, the gas control knobs should be off. The propane bottle should be turned off. If not, wait 15 minutes. Turn cylinder all the way on. Turn left burner to ignite, wait 5 seconds then ignite. Repeat for additional burners. -- Check all gas connections for leaks with bubble test. If leaks are found, replace the part or tighten the fitting.
Grill takes a long time to preheat.	<ul style="list-style-type: none"> -- Normal preheat 500-600 °F takes about 10-15 min. Cold weather and wind may affect your preheat time. -- Volcanic rock and Briquettes should not be used in this BBQ.
Burner flames are not light blue.	<ul style="list-style-type: none"> -- Too much or not enough air mixes for the flame. -- Elevation is the principal cause, however cold weather can affect the mixture. -- Grill is in a windy location.

TROUBLE SHOOTING

BEFORE CALLING FOR SERVICE

If the grill does not function properly, use the following checklist before contacting your dealer for service. You may save the cost of a service call.

Problem	PossibleCause	Prevention/Solution
Burner(s) will not light using ignitor.	<ul style="list-style-type: none"> • Wire and/or electrode covered with cooking residue. • Electrode cracked or broken "sparks at crack". • Electrode tip not in proper position. • Wires are loose or disconnected. • Wires are shorting (sparking) between ignitor and electrode. • Dead battery. 	<ul style="list-style-type: none"> • Clean wire and/or electrode with rubbing alcohol and clean swab. • Replace electrode(s). • Reconnect wires or replace electrode/wire assembly. • Replace ignitor wire/electrode assembly. • Replace with a new AA battery.
Burner(s) will not match light.	<ul style="list-style-type: none"> • No gas flow. • Coupling nut and regulator not fully connected. • Obstruction of gas flow. • Disengagement of burner to valve. • Is grill assembled correctly? 	<ul style="list-style-type: none"> • Check to see if LP tank is empty. If LP tank is not empty, refer to "Sudden drop in gas flow". • Turn the coupling nut about one-half to three quarters additional turn until solid stop. Tighten by hand only-do not use tools. • Clear burner tube(s). • Reengage burner and valve. • Check steps in assembly instructions.
Sudden drop in gas flow or low flame.	<ul style="list-style-type: none"> • Out of gas. • Excess flow valve tripped. 	<ul style="list-style-type: none"> • Check for gas in LP tank. • Turn off knobs, wait 30 seconds and light grill. If flames are still low, turn off knobs and LP tank valve. Disconnect regulator. Reconnect regulator and leak test. Turn on LP tank valve, wait 30 seconds and then light grill.
Flames blow out	<ul style="list-style-type: none"> • High or gusting winds. • Low on LP gas. • Excess flow valve tripped. 	<ul style="list-style-type: none"> • Turn front of grill to face wind or increase flame height. • Refill LP tank. • Refer to "Sudden drop in gas flow" above.
Flare-up.	<ul style="list-style-type: none"> • Grease buildup. • Excessive fat in meat. • Excessive cooking temperature. 	<ul style="list-style-type: none"> • Clean grill. • Trim fat from meat before grilling. • Adjust (lower) temperature accordingly.
Persistent grease fire.	<ul style="list-style-type: none"> • Grease trapped by food buildup around burner system. 	<ul style="list-style-type: none"> • Turn knobs to OFF. Turn gas off at LP tank. Leave lid in position and let fire burn out. After grill cools, remove and clean all parts.
Flashback... (fire in burner tube(s)).	<ul style="list-style-type: none"> • Burner and/or burner tubes are blocked. 	<ul style="list-style-type: none"> • Turn knobs to OFF. Clean burner and/or burner tubes.
Unable to fill LP tank.	<ul style="list-style-type: none"> • Some dealers have older fill nozzles with worn threads. 	<ul style="list-style-type: none"> • The worn nozzles don't have enough "bite" to engage the valve. Try a second LP dealer.

TROUBLE SHOOTING

BEFORE CALLING FOR SERVICE

If the grill does not function properly, use the following checklist before contacting your dealer for service. You may save the cost of a service call.

Problem	Possible Cause	Check Procedure	Prevention/Solution
No sparks appear at any electrodes when ignition button is pushed; no noise can be heard from spark module.	• Battery not installed properly.	• Check battery orientation	• Install battery(make sure that and " • " connectors are oriented correctly, with end up and end down.
	• Dead battery	• Has battery been used previously?	• Replace battery with new AA-size alkaline battery.
	• Button assembled not installed properly.	• Check to insure threads are properly engaged. Button should travel up and down without binding.	• Unscrew button cap assembly and reinstall,make sure threads are aligned and engaged fully.
	• Faulty spark module.	• If no sparks are generated with new battery and good wire	• Replace spark module assembly.
No sparks appear at any electrodes when ignition switch is pushed; noise can be heard from spark module.	• Out put lead connections not completed.	• Are output connections on and tight?	• Remove and reconnect all output connections at module and electrodes.
Sparks are present but not at all electrodes and/or not at full strength.	• Output lead connections not complete.	• Are output connections on and tight?	• Remove and reconnect all connections at module and electrodes.
	• Arcing to grill away from burner(s)	• If possible, observe grill in dark location. Operate ignition system and look for arcing between output wires and grill flames.	• If sparks are observed other than from burner(s), wire insulation maybe damaged. Replace wires.
	• Weak battery	• All sparks present but weak or at slow rate.	• Replace battery with a new AA-size alkaline battery.
	• Electrodes are wet	• Has moisture accumulated on electrode and/or in burner ports?	• Use paper towel to remove moisture.
	• Electrodes cracked or broken sparks at crack	• Inspect electrodes for cracks.	• Replace cracked or broken electrodes.

WARRANTY INFORMATION

The appliance has been manufactured under the highest standard of quality and workmanship. We warrant to the original consumer purchaser that all aspects of this product will be free of defects in material and workmanship for one (1) year from the date of purchase. A replacement for any defective part will be supplied free of charge for installation by the consumer. Defects or damage caused by the use of other than genuine parts are not covered by this warranty. This warranty shall be effective from the date of purchase as shown in the purchaser's receipt.

This warranty is valid for the original consumer purchaser only and excludes industrial, commercial or business use of the product, product damage due to shipment or failure which results from alteration, product abuse, or product misuse, whether performed by a contractor, service company, or consumer. We will not be responsible for labor charges and/or damage incurred in installation, repair or replacement, nor for incidental or consequential damage.

service@vestivium.com
www.vestivium.com