

ASSEMBLY INSTRUCTIONS

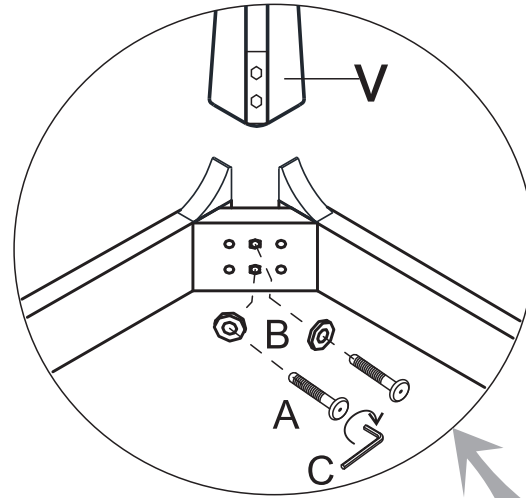

Parts

u=1X

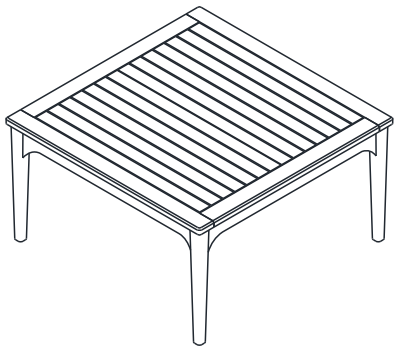
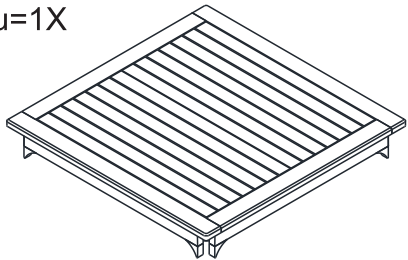

v=4X

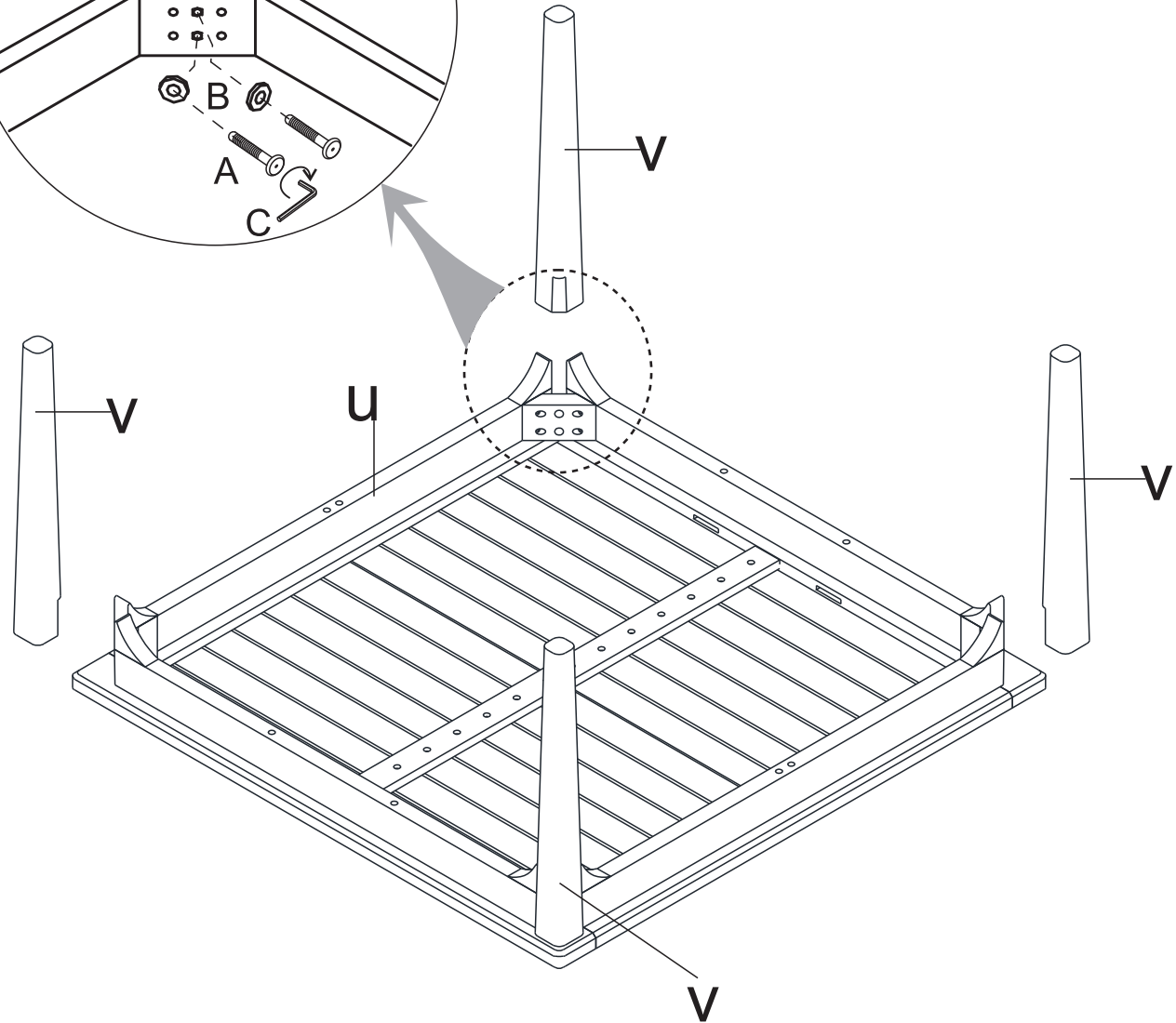

Hardwares

A=8X  (M6x60)

B=8X 

Tools

C=1X 

Parts

u=1X

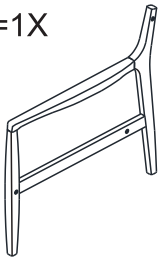

v=1X

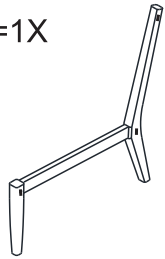

w=1X

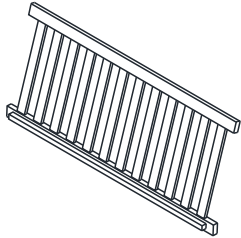

x=2X

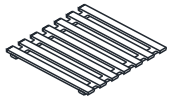

y=1X

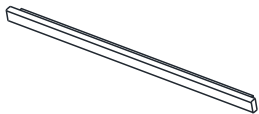

Hardwares

A=6X



(M6x70)

B=6X



(M6x13)

C=8X



(M4x25)

Tools

D=1X



(M6x50)

E=1X



ASSEMBLY INSTRUCTIONS

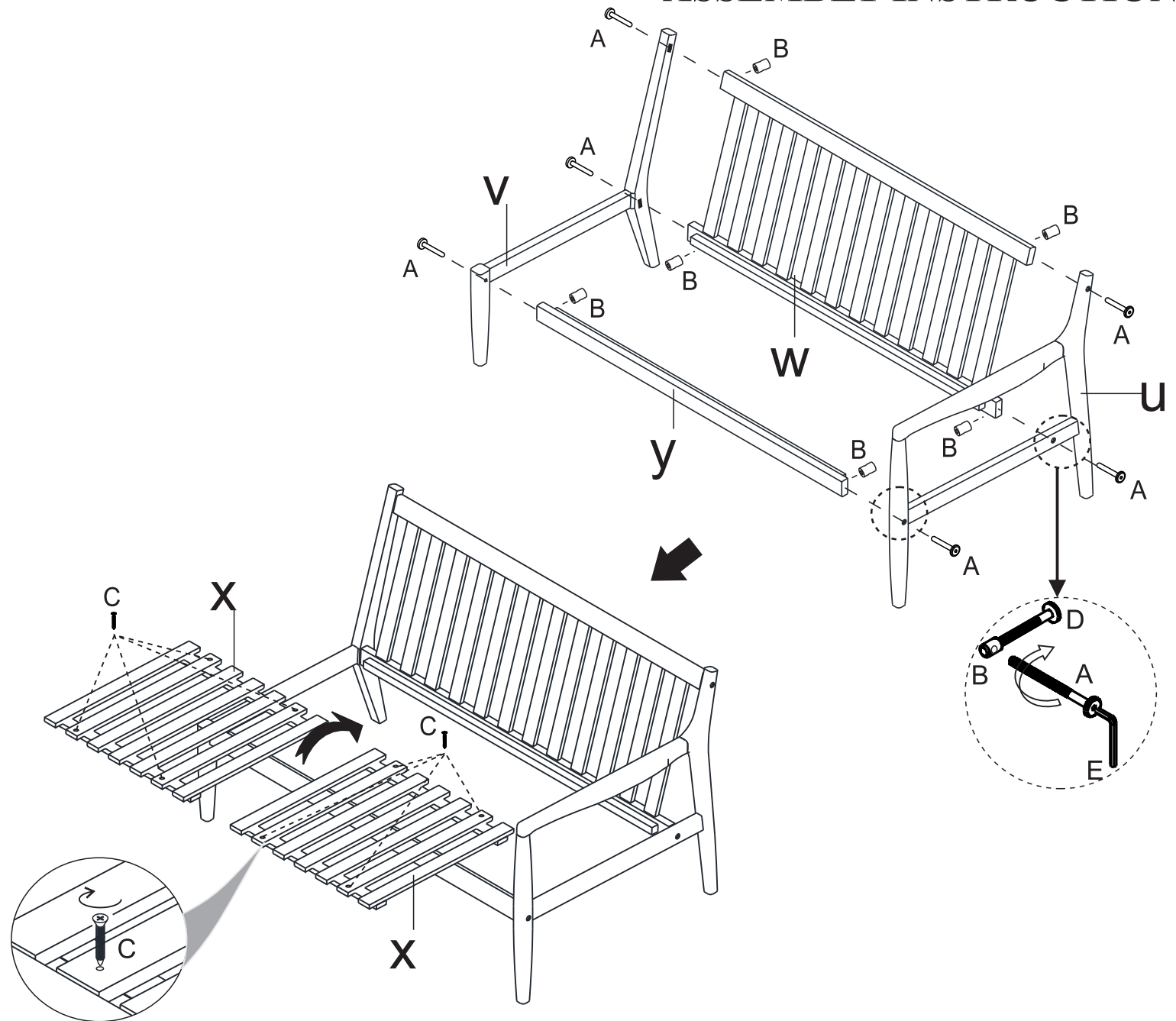

Parts

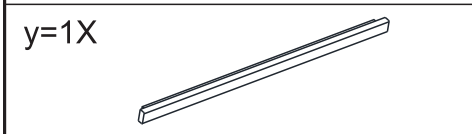
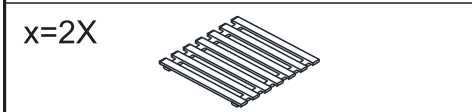
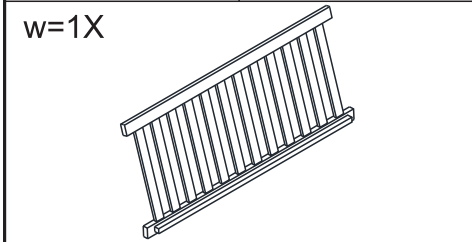
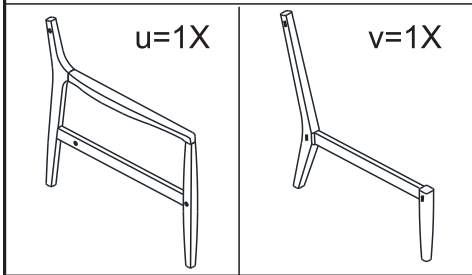

Hardwares

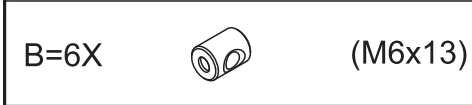
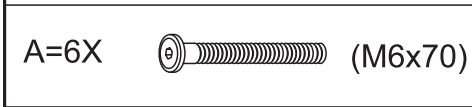

Tools

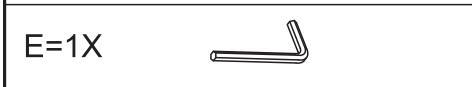
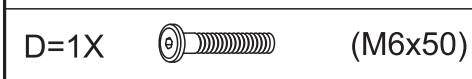

ASSEMBLY INSTRUCTIONS

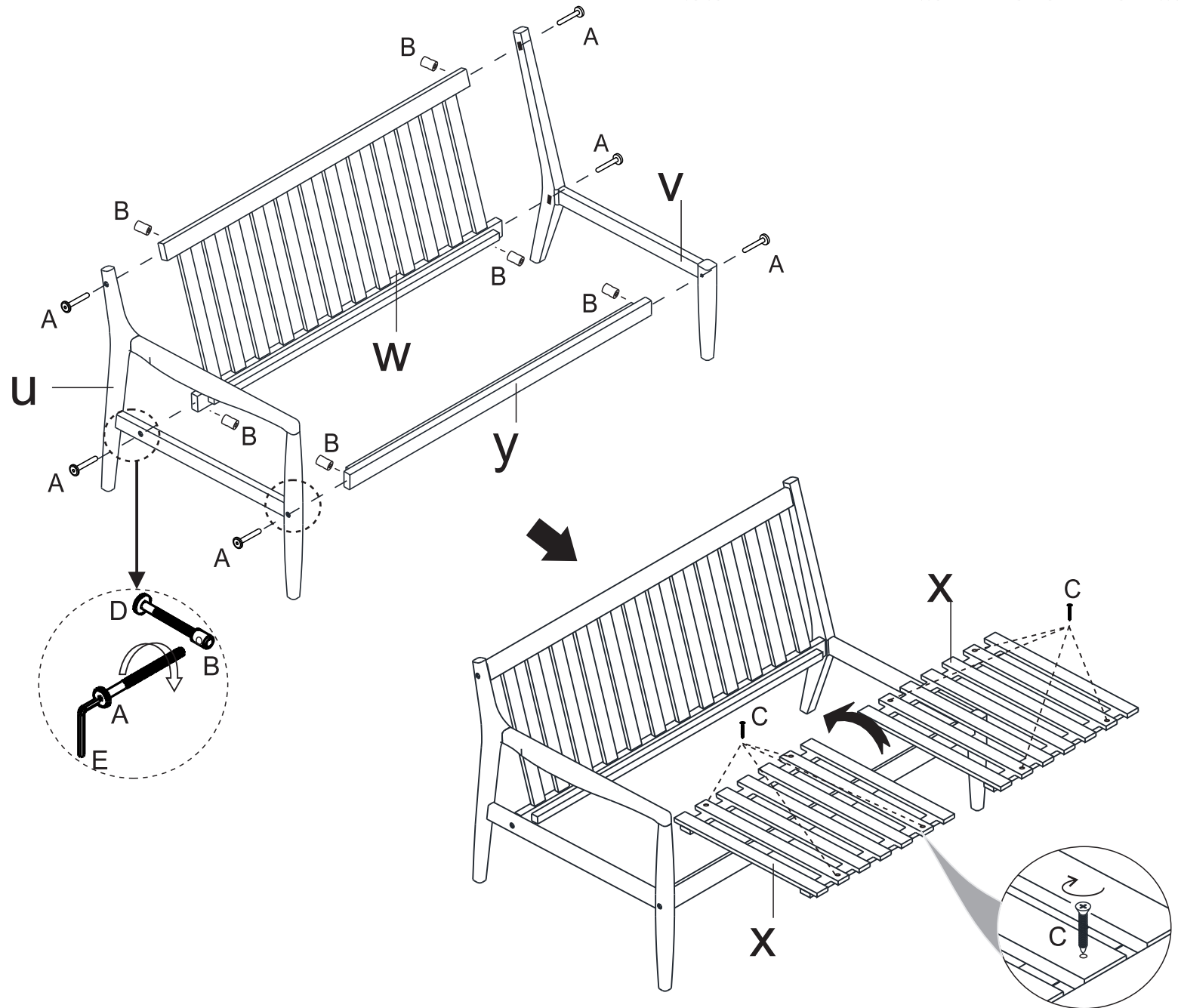





ASSEMBLY INSTRUCTIONS

Parts

u=1X	v=1X
w=1X	
x=2X	
y=1X	

Hardwares

A=1X		(M6x90)
B=3X		(M6x70)
C=4X		(M6x13)
D=4X		(M4x25)
E=4X		(M6x40)

Tools

F=1X		(M6x50)
G=1X	