

WICHTIG - FÜR SPÄTERE VERWENDUNG
AUFBEWAHREN - SORGFÄLTIG LESEN

IMPORTANTE, conservare per utilizzi futuri,
leggere attentamente.

VIGTIGT - Samvejledningen skal opbevares
i arkiv til senere brug - Skal gennemlæses nøje

NOTICE - These instructions must be saved
for future use - Instructions must be followed

IMPORTANT - Veuillez conserver
la notice de montage dans le cadre
d'une prochaine utilisation.
Parcourir cette notice avec attention

TEILCHECKLISTE
 DISTINTA DELLE PARTI
 TJEKLISTE
 CHECK LIST
 LISTE DE CONTROLE

Réf./No.	Réf./Art.	Qty./Stck./Quantité	Size / Maß / Dimension (mm)	Qty./Stck./Quantité	✓
1	32545102	1	1200x400x105		
2	32545202	2	737x76x50		
3	32545302	2	737x76x50		

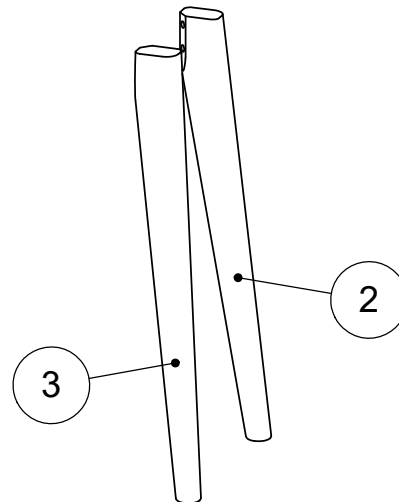
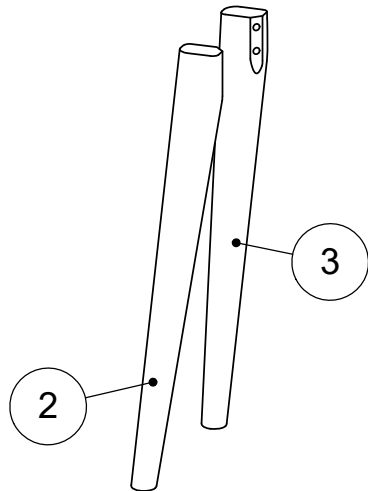
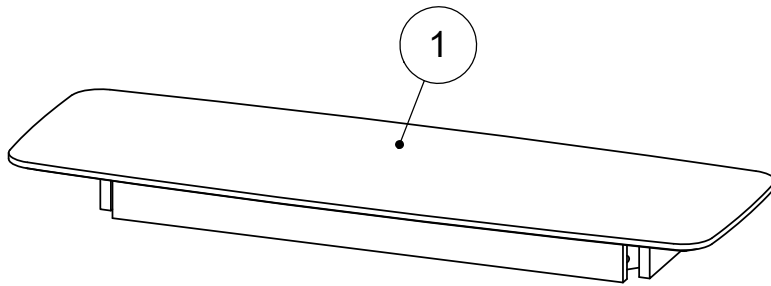

Sollten Sie eventuelle Ersatzteile
 oder Reklamationsteile fordern,
 dann bitten wir Sie, diese Seite
 mitzubringen.

Per richiedere eventuali parti
 di ricambio o di sostituzione,
 La invitiamo a presentare questa pagina.

Skulle de få brug for reklamationsdele,
 beder vi dem medsende denne side







If you should be in the need of spareparts,
 please enclose this page.

En cas de service apres - vente, veuillez nous
 retourner ce coupon

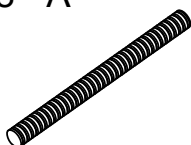

TEILCHECKLISTE - DISTINTA DELLE PARTI - TJEKLISTE - CHECK LIST - LISTE DE CONTROLE

Réf./No.	Réf./Art.	Qty./Stck./Quantité	✓
A	323242	8	
B	323242	8	
C	323242	8	
D	323242	8	
E	323242	1	
F	323242	4	

8 - A	8 - B	8 - C	8 - D	1 - E	4 - F
 M8x95mm	 M8	 M8	 M8		 Ø35

Geehrter Kunde.
Hier haben Sie die Möglichkeit die mitgelieferten
Schrauben nachzumessen.

Egregio cliente,
Controllare le misure delle viti fornite in dotazione.

Kære kunde.
Her har De muligheden for at måle medsendte beslag.

Dear Customer.
Below you have the opportunity to measure the
Enclosed Hardware.

Cher Client.
La règle ci jointe vous permet de mesurer la visserie.

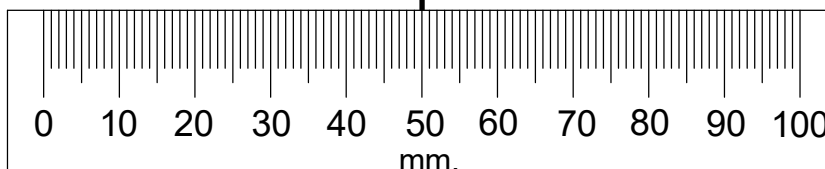

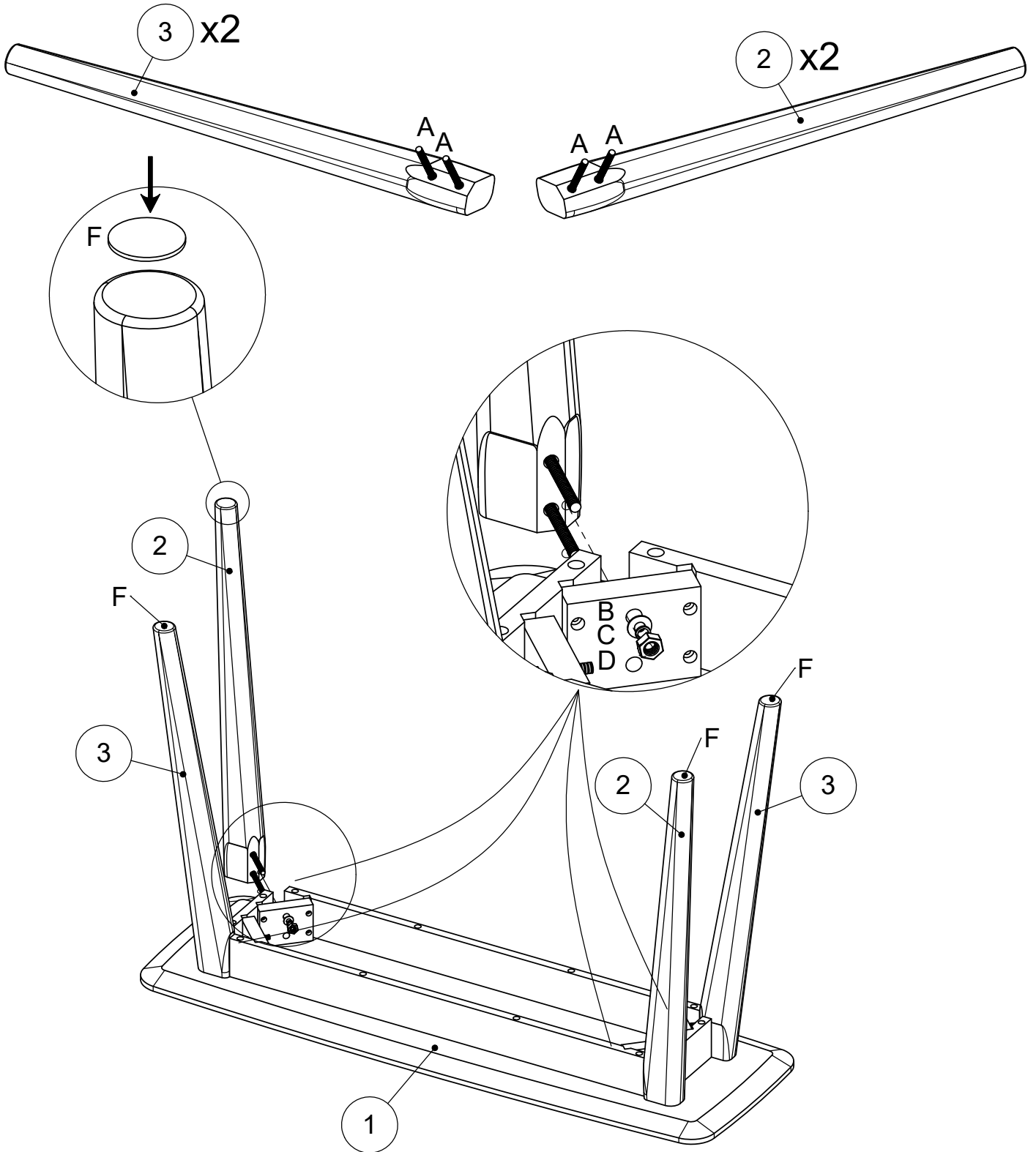
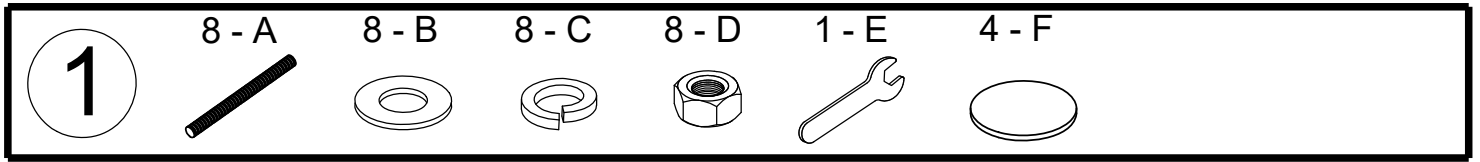

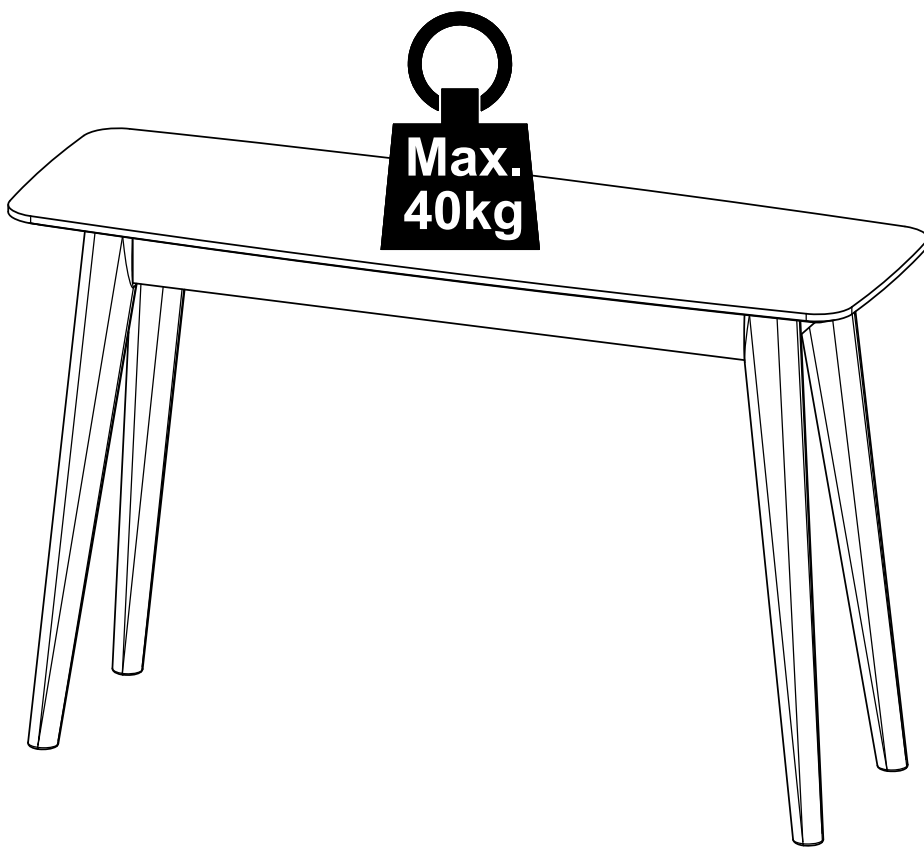



UK:

Always ensure the feet / felt pads provided with this product are suitable for your flooring.
Periodically check the position of any foot caps/felt pads used to ensure your floors are protected.

DE:

Wichtig : Bitte stellen Sie immer sicher , dass die mit diesem Produkt gelieferten FüÙe für Ihren Bodenbelag geeignet sind !
Bitte überprüfen Sie regelmäßig die Position der verwendeten Fußkappen oder Filzgleiter um sicherzustellen dass Ihre Böden geschützt sind !

ES:

Asegúrese siempre que los tapones de las patas de este producto son compatibles con su suelo.
Periódicamente revise que sus tapones y sus almohadillas de fieltro están correctamente colocadas para asegurar que su suelo esté protegido.

FR:

Assurez-vous toujours que les pieds/ patins fournis avec le produit sont compatibles avec le sol.
Contrôlez régulièrement la position des patins utilisés pour que vos sols soient protégés.

DK:

Sørg altid for at beskyttelse fødder / filt-puderne der følger med dette produkt, passer til Deres gulv.
Kontroller regelmæssigt placeringen at evt. beskyttelse fødder / filt-puder er korrekt placeret for bedste beskyttelse af gulvene.