



# Assembly Instruction



Collection: CARISSA





Item No: D422-21

CARISSA DINING BENCH (1 PER CARTON)

Thank you for purchasing this quality product. Be sure to check all packing materials carefully for small parts which may have come loose inside the carton during shipment. Identify and count all items and compare with the PARTS LIST and/or HARDWARE LIST shown below.

1. We recommend that you assemble this product with the assistance of another person; this will make the assembly easier, and will help eliminate damage to the product or injury to persons during assembly.
2. Please do not tighten screws or bolts until the assembly is completed.
3. To level the chairs or table, before tightening all the screws, the chairs or table must be placed on a flat surface and then tighten the screws.
4. Please put all parts on a non-abrasive floor before assembly and follow the assembly steps to assemble your newly purchased product correctly and efficiently.

PARTS LIST			
No.	DESCRIPTION	SKETCH	Q'TY
A	SEAT CUSHION		1
B	BENCH LEG		2
WEIGHT CAPACITY (PER BENCH)		507 LBS	

HARDWARE LIST			
No.	DESCRIPTION	SKETCH	Q'TY
1	ALLEN BOLT (5/16"x2-1/4")		8
2	SPRING WASHER (5/16")		8
3	FLAT WASHER (5/16"x3/4)		8
4	ALLEN KEY (M5x2-1/2")		1

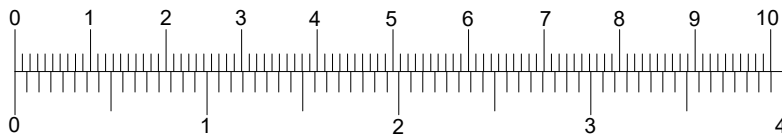

## STEP 1:

Place the seat cushion (A) upside down on a soft and clean surface.

Assemble the bench legs (B) with the seat cushion (A) by using Allen Key (4) with hardware 1, 2, and 3.

**\*\*Attention: DO NOT TIGHTEN THE BOLTS.**

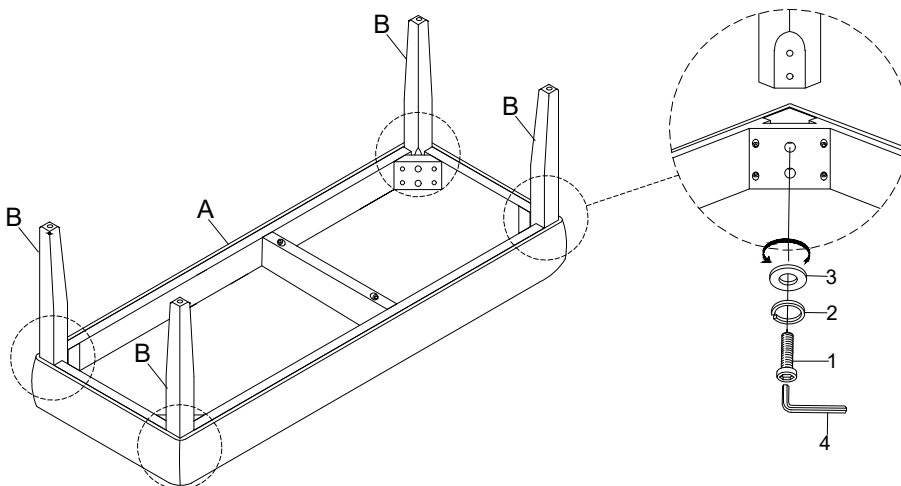

MADE IN VIETNAM



## Assembly Instruction

Collection: CARISSA

Item No: D422-21

CARISSA DINING BENCH (1 PER CARTON)

### STEP 2:

To level the bench, turn the bench right side up on a flat surface and tighten the bolts with Allen Key (4)

**\*\*Attention: DO NOT OVERTIGHTEN THE BOLTS.**

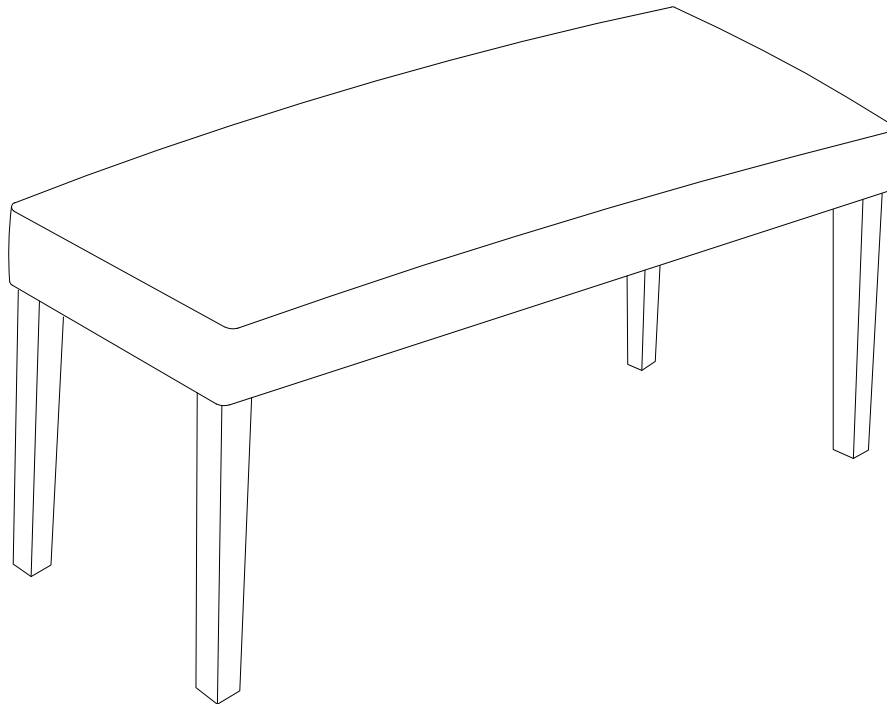

MADE IN VIETNAM