

ASSEMBLY INSTRUCTIONS

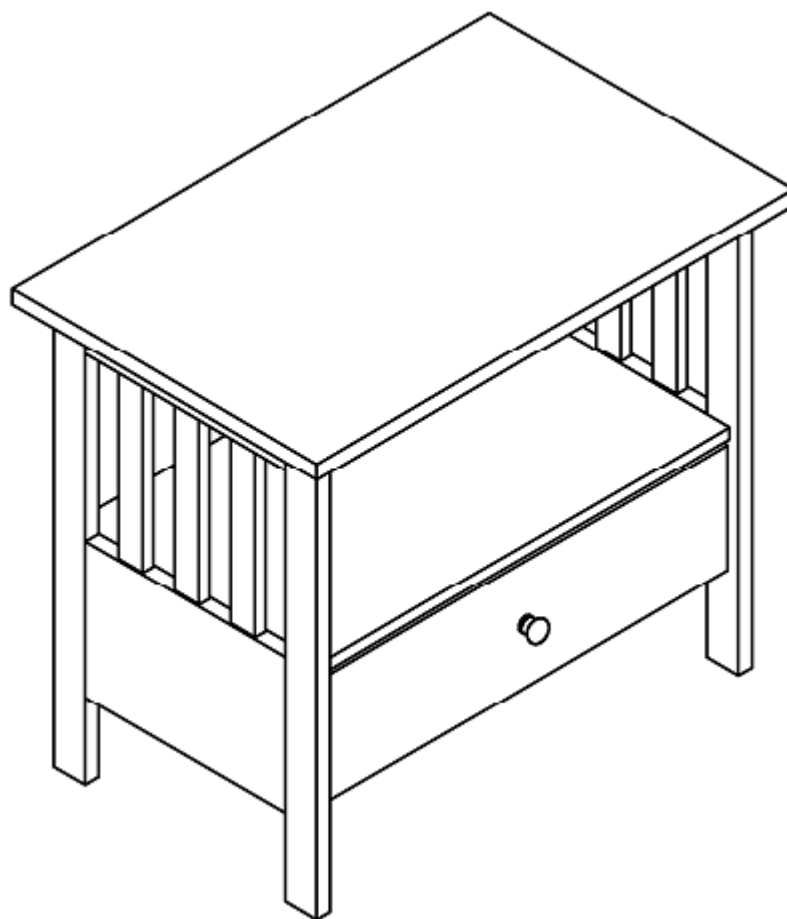

Description : TV/VCR STAND

BEFORE ASSEMBLY

Thank you for purchasing this quality product. This product has been designed for easy assembly and constructed for durability. All parts were checked prior to packaging to insure quality. Prior to beginning assembly, however, make sure all parts and hardware are included and free of obvious defect. If a part is missing or defective, please contact the store where purchased.

IMPORTANT NOTE:

- Place all wooden parts on a clean and smooth surface such as a rug or carpet to avoid the parts from being scratched.
- Remove all wrapping material, including staples & packing straps before you start to assemble.
- DO NOT tighten all screws and bolts until completely assembled.
- Keep all hardware parts out of reach of children.

ASSEMBLY TOOLS REQUIRED NOT INCLUDED

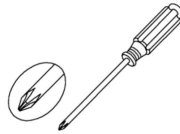





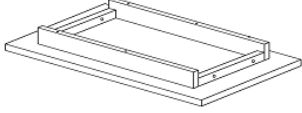
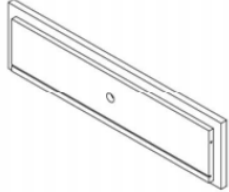
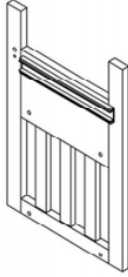
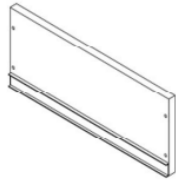
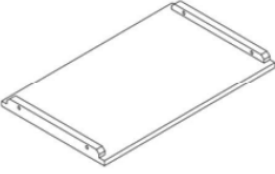
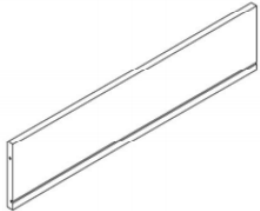
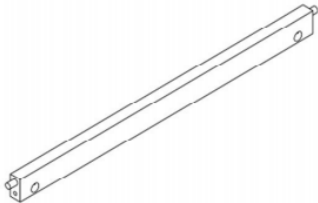
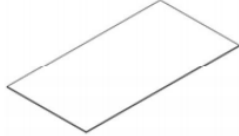
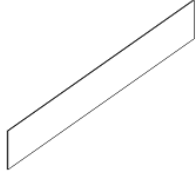

PART LIST

When unpacking, please be careful not to discard any parts with the packaging. Before continuing, please make sure you have the following parts:

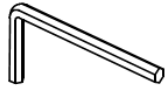
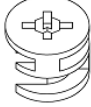
NO	Description	Qty	Sketch	NO	Description	Qty	Sketch
A	Top panel	1		F	Drawer front panel	1	
B	Side frame (L-R)	2		G	Drawer side panel	2	
C	Bottom shelf	1		H	Drawer back panel	1	
D	Support Rail	1		I	Drawer bottom panel	1	
E	BACK PANEL	1					

HARDWARE LIST

When unpacking, please be careful not to discard any parts with the packaging. Before continuing, please make sure you have all of the following hardware:

No	Description	Qty	Sketch	No	Description	Qty	Sketch
1	Bolt (M6x35mm)	8		2	Allen key (4X80mm)	1	
3	Camlock	2		4	Cambolt	2	
5	Wood screw (M4x30mm)	8		6	Flat washer (Φ6.5x19mm)	8	
7	Spring washer (Φ6.5x11mm)	8		8	Knob	1	
9	Pan head screw (M4x35mm)	1					

STEP 1

Attached cambolt (4) to the side frames (B) as shown below. Tighten with a screwdriver.

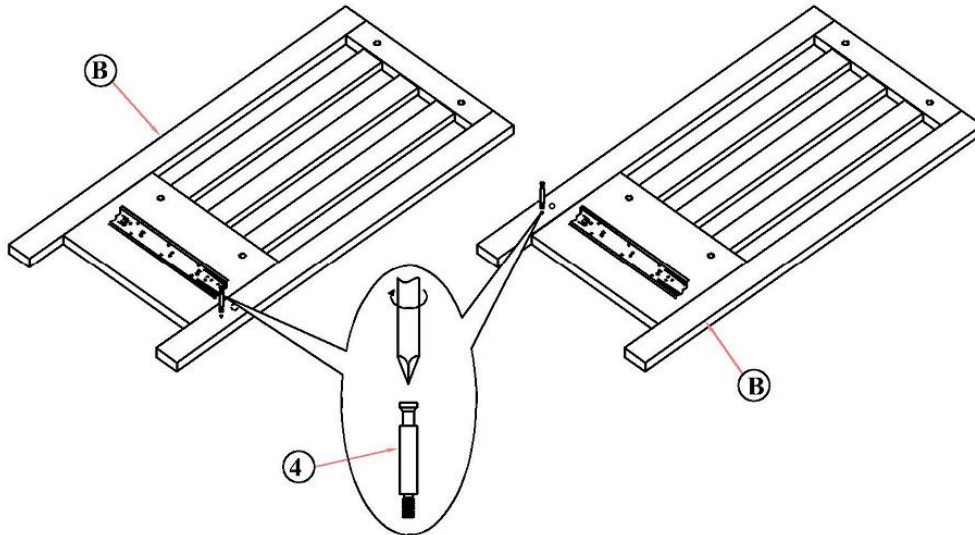

STEP 2

Attached the support rail (D) to the side frames (B) with the camlock (3). Tighten with Allen key (2)

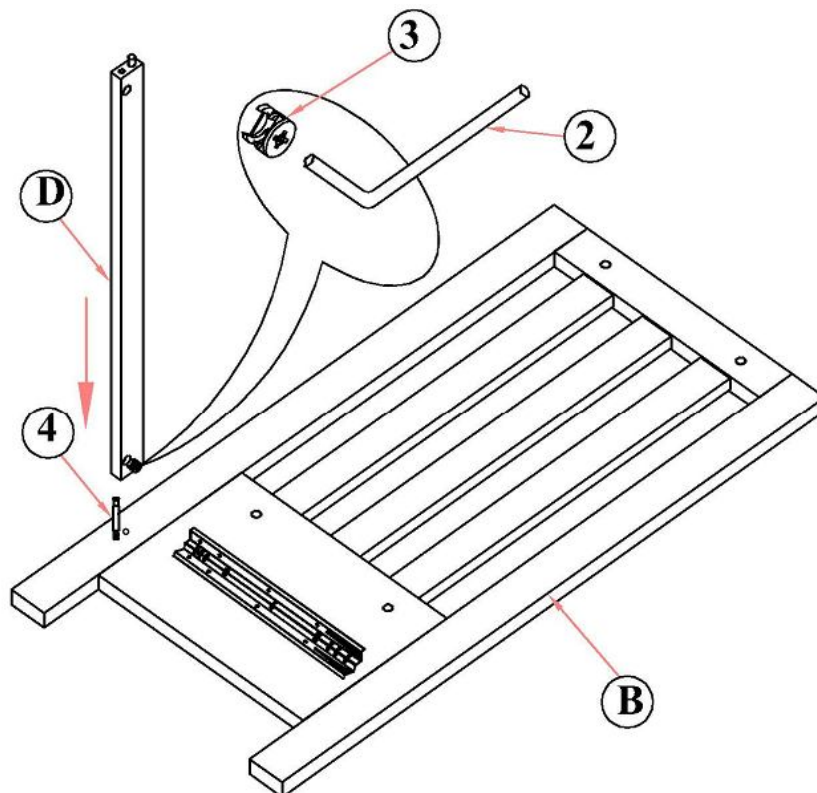

STEP 3

Attach the bottom self (C) to the side frames (B) with bolts (1), and washers (6) and (7). Tighten with Allen key (2).

Slide the back panel (E) into the grooves as shown below.

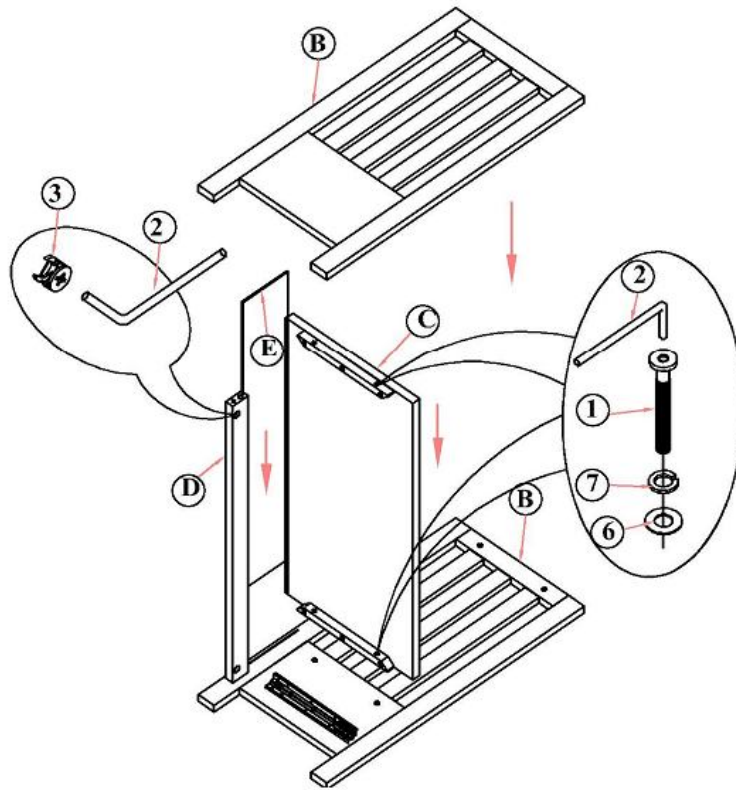

STEP 4

Attach Top (A) to the unit with bolts (1), and washers (6) and (7) as shown below. Tighten with Allen key (2).

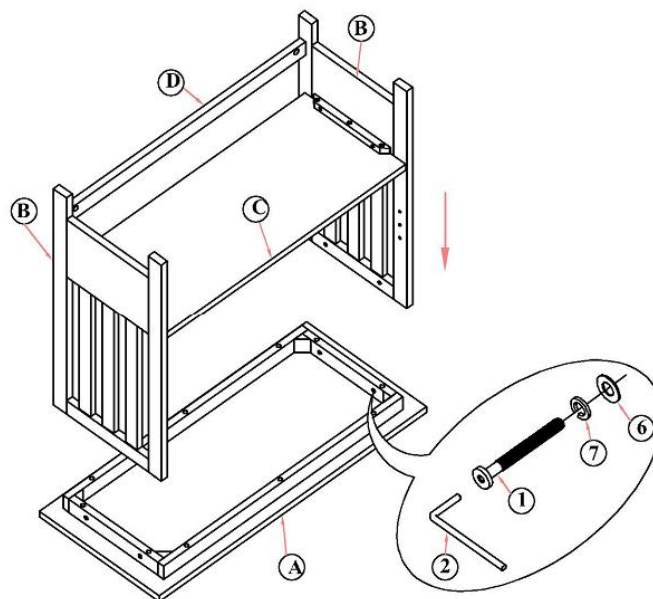

STEP 5

Attach drawers side panel (G) to the drawer front panel (F) with screws (5) as shown below. Tighten with a screwdriver.

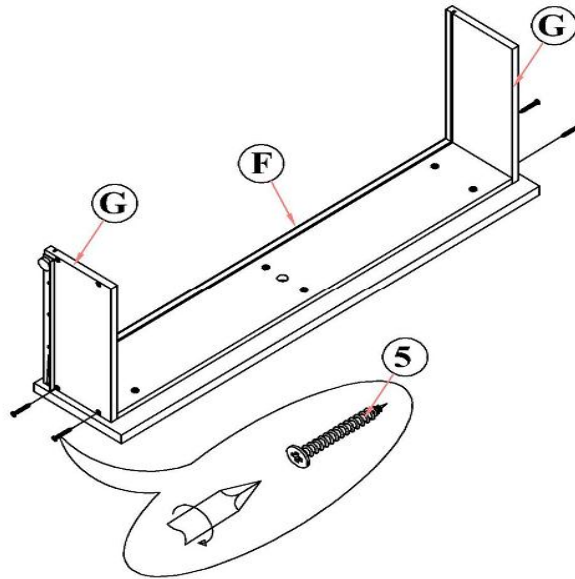

STEP 6

Slide the drawer bottom panel (I) into the grooves as shown below.

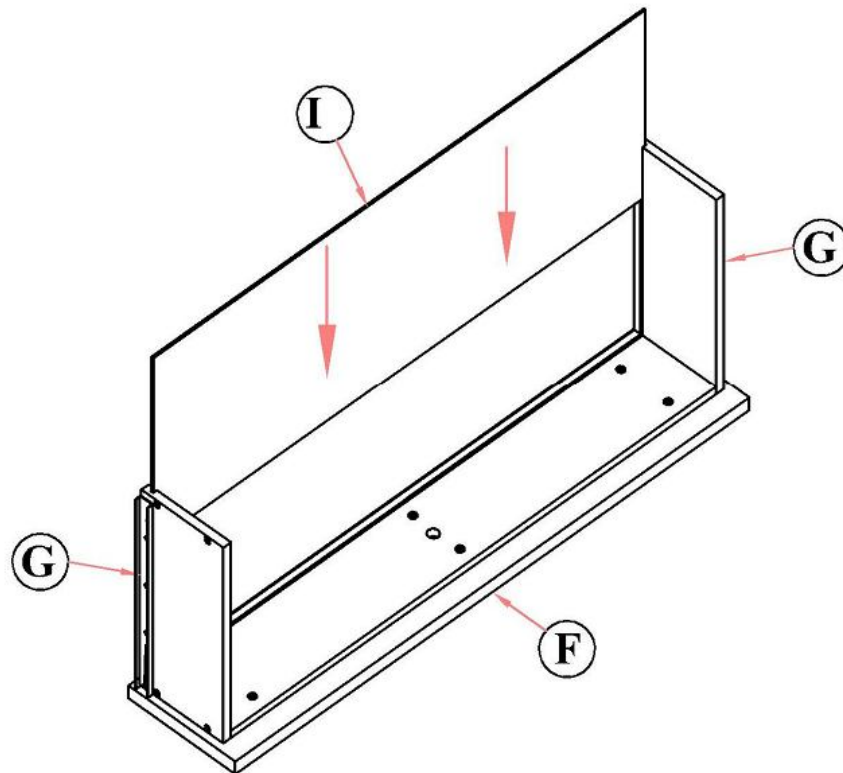

STEP 7

Attached the drawer back panel (H) to the drawer (from step 6) with screws (5) as shown below. Tighten with a screwdriver.

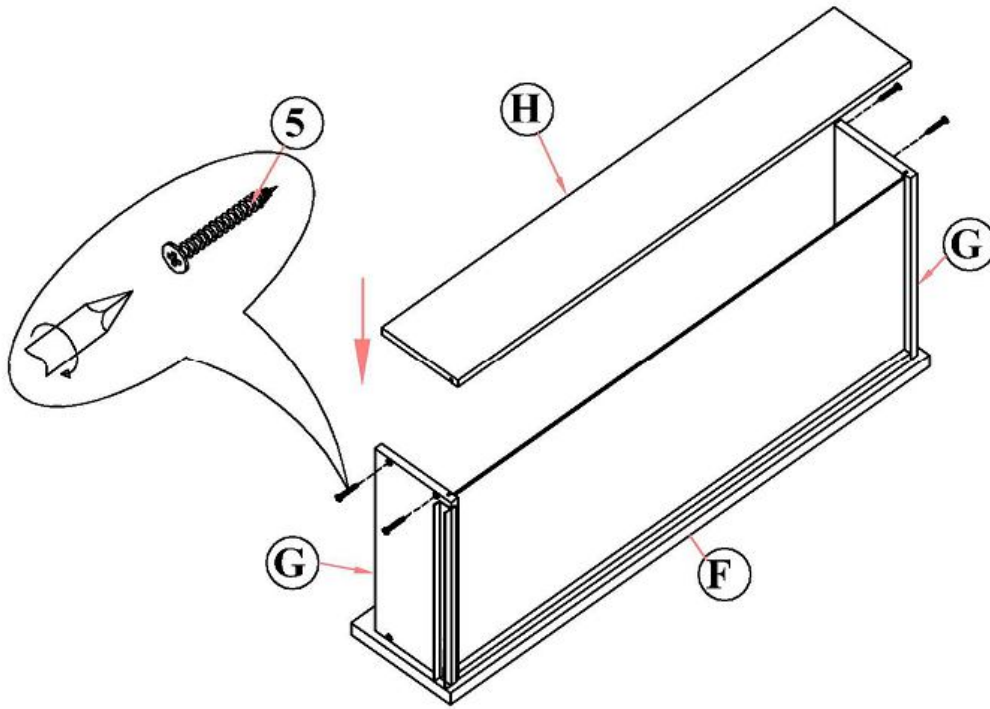

STEP 8

Attached the knobs (8) to the drawer front with Pan head screw (9). Tighten with a screwdriver.

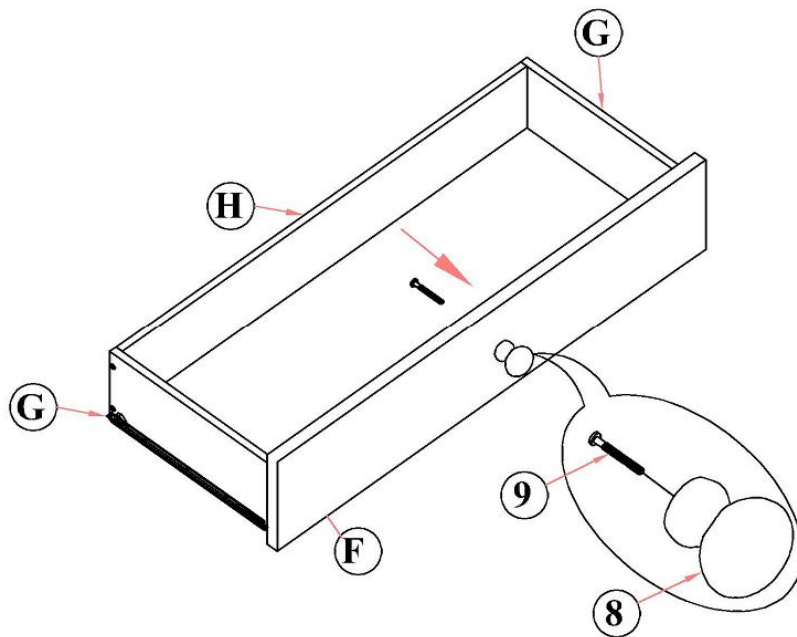

STEP 9

Insert the drawer into the unit as shown below.

