









ASSEMBLY INSTRUCTIONS

HARDWARE LIST

CARTON	NO.	SKETCH	DESCRIPTION	QTY
3-3	1		Bolt (1/4"x1-7/8")	6 PCS
	2		Bolt (1/4"x1-1/8")	4 PCS
	3		Bolt (1/4"x3/4")	8 PCS
	4		Spring Washer (1/4")	18PCS
	5		Washer(1/4")	18 PCS
	6		Allen wrench (4mm)	1 PC

PARTS LIST

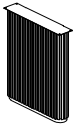
CARTON	NO.	SKETCH	DESCRIPTION	QTY
3-1	A		Table top	1 PC
3-2	B		Base Frame	1 PC
3-3	C		Leg	2 PCS

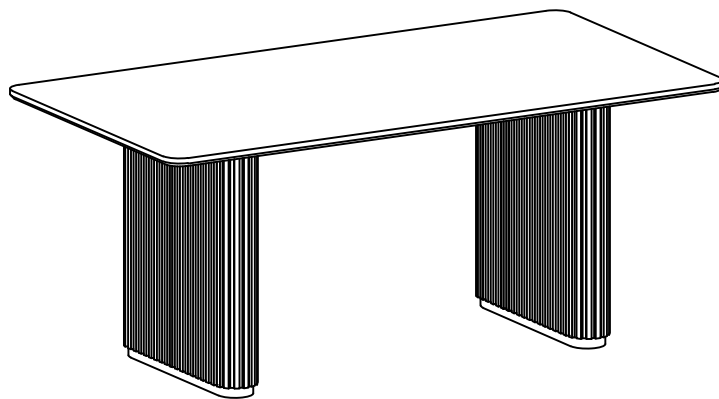

Notice:

- 1、 Follow the installation instructions. Please confirm all accessories are present before installation.
- 2、 Tighten the screws only after the screw holes of the components are perfectly aligned.
- 3、 If you encounter any issues during installation, please contact our customer service for assistance.
- 4、 Unbox the item from the side labeled "Open" and lay a protective mat or cloth on the floor to avoid scratches.

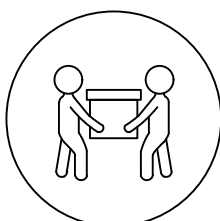

Recommended Assembly:
2 people

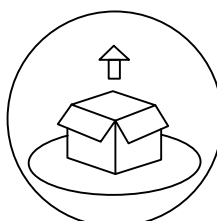

Lay a protective mat
of cloth

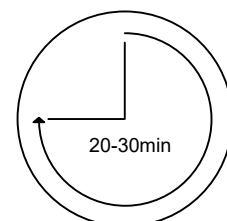

Estimate Installation time

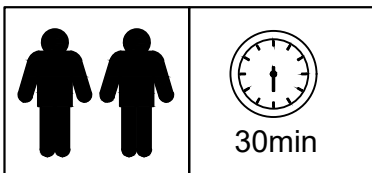

ASSEMBLY INSTRUCTIONS

Step 1

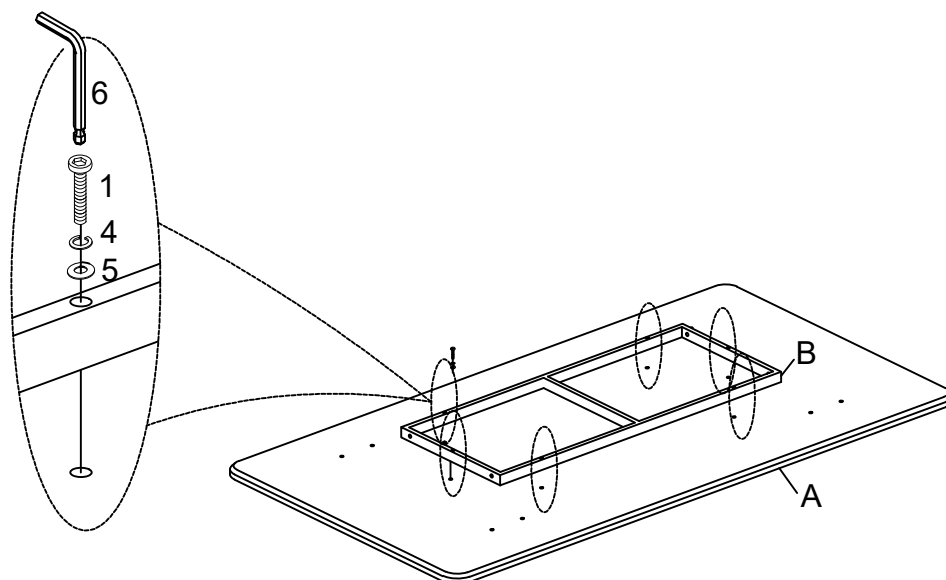

In this step, tighten the screws to 80%.
Note: Do not lock the screws.

Step 2

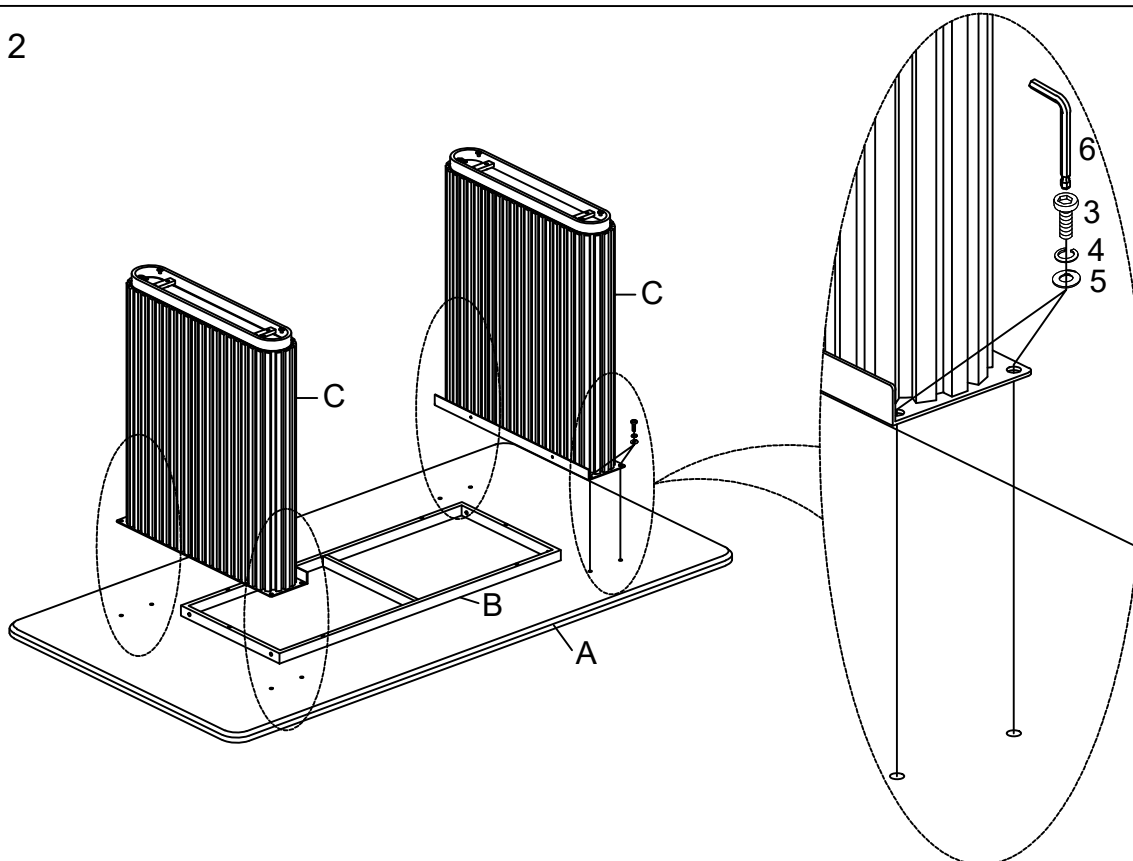

In this step, tighten the screws to 80%.
Note: Do not lock the screws.

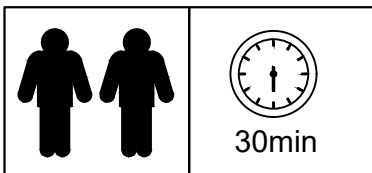

ASSEMBLY INSTRUCTIONS

Step 4

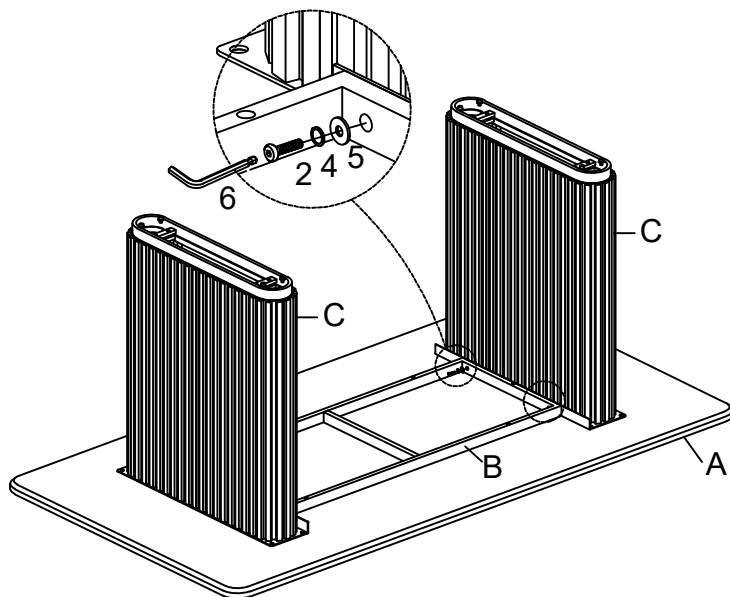

In this step, tighten the screws to 80%.
Note: Do not lock the screws.

Step 5

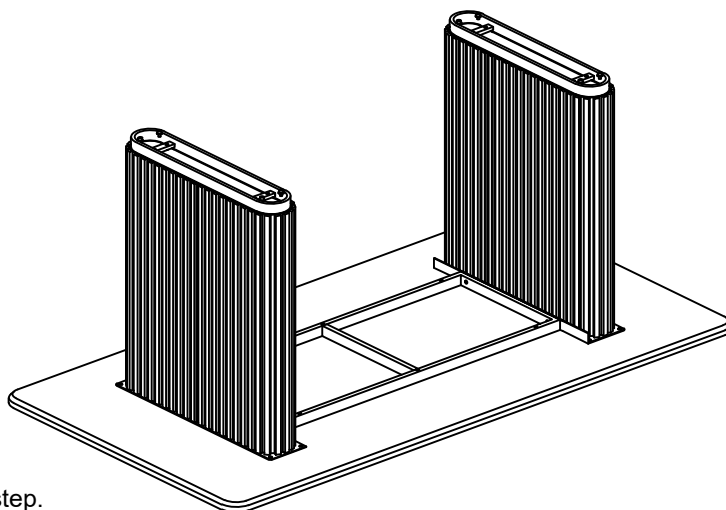

Note: Fully tighten all bolts at this step.

Step 6

