

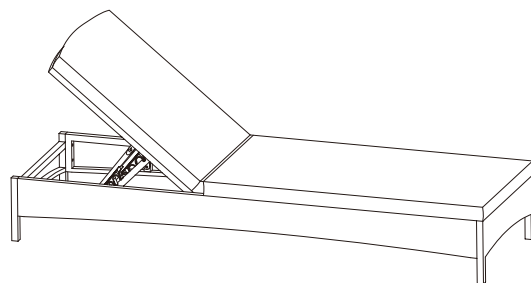

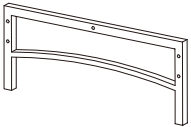

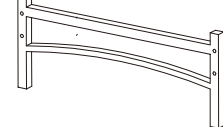

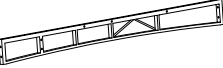
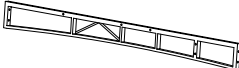
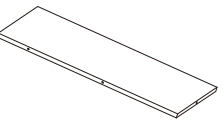
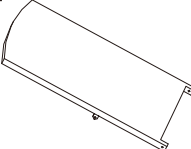

Outdoor Wicker Chaise Lounge

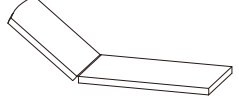

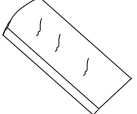

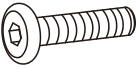
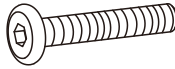

PART LIST

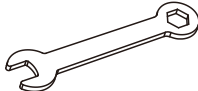
				
<p>Front Panel 1 PC</p>	<p>Back Panel 1 PC</p>	<p>Right side Panel 1 PC</p>	<p>Left side Panel 1 PC</p>	<p>Seat Panel 1 PC</p>
				
<p>Backrest Panel 1 PC</p>	<p>Bar 1 PC</p>	<p>U Bar 1 PC</p>	<p>Cover of Cushion * 1 PC</p>	<p>Core of Seat Cushion 1 PC</p>
	<p>*Please note cushion covers will ship separately.</p>			
<p>Core of Back Cushion 1 PC</p>				

HARDWARE LIST

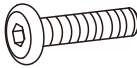
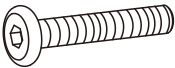
				
<p>#1 M6*20mm Short Bolt 6 PCS</p>	<p>#2 M6*45mm Bolt 15 PCS</p>	<p>#3 M6mm Nut 2 PCS</p>	<p>#4 M6mm Flat Washer 23 PCS</p>	<p>#5 Plastic Washer 4 PCS</p>
				
<p>#6 M6mm Allen Key 1 PC</p>	<p>#7 M6mm Wrench 1 PC</p>			

EXTRA HARDWARE LIST

				
<p>#1 M6*20mm Short Bolt 1 PC</p>	<p>#2 M6*45mm Bolt 1 PC</p>	<p>#3 M6mm Nut 1 PC</p>	<p>#4 M6mm Washer 1 PC</p>	<p>#5 Plastic Washer 1 PC</p>

Step 1. Lay the right side panel (part C) down on a soft flat surface, such as carpet, as shown below. Attach front panel (part A) to right side panel (part C) using bolts (part #2), washers (part #4) and allen key (part #6).

NOTE: Please do not fully tighten bolts until unit is fully assembled.

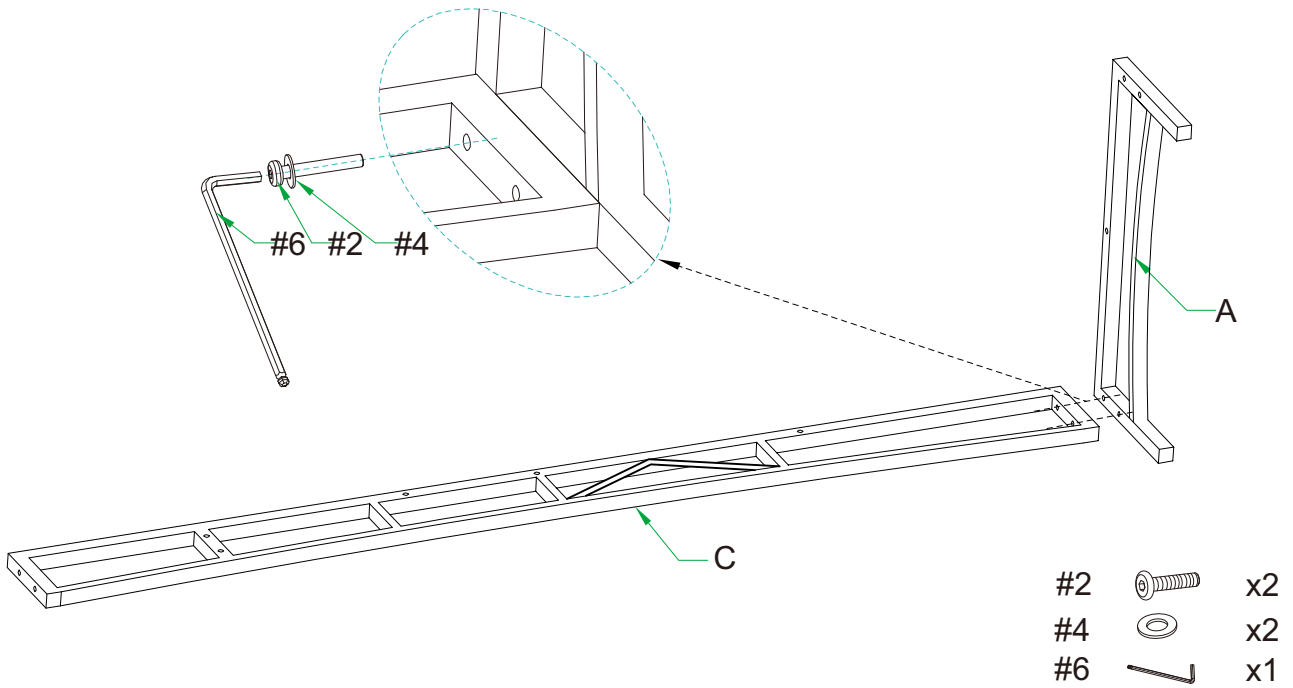

Step 2. Attach seat panel (part E) to right side panel (part C) and front panel (part A) using bolts (part #2), washers (part #4) and allen key (part #6).

NOTE: Please do not fully tighten bolts until unit is fully assembled.

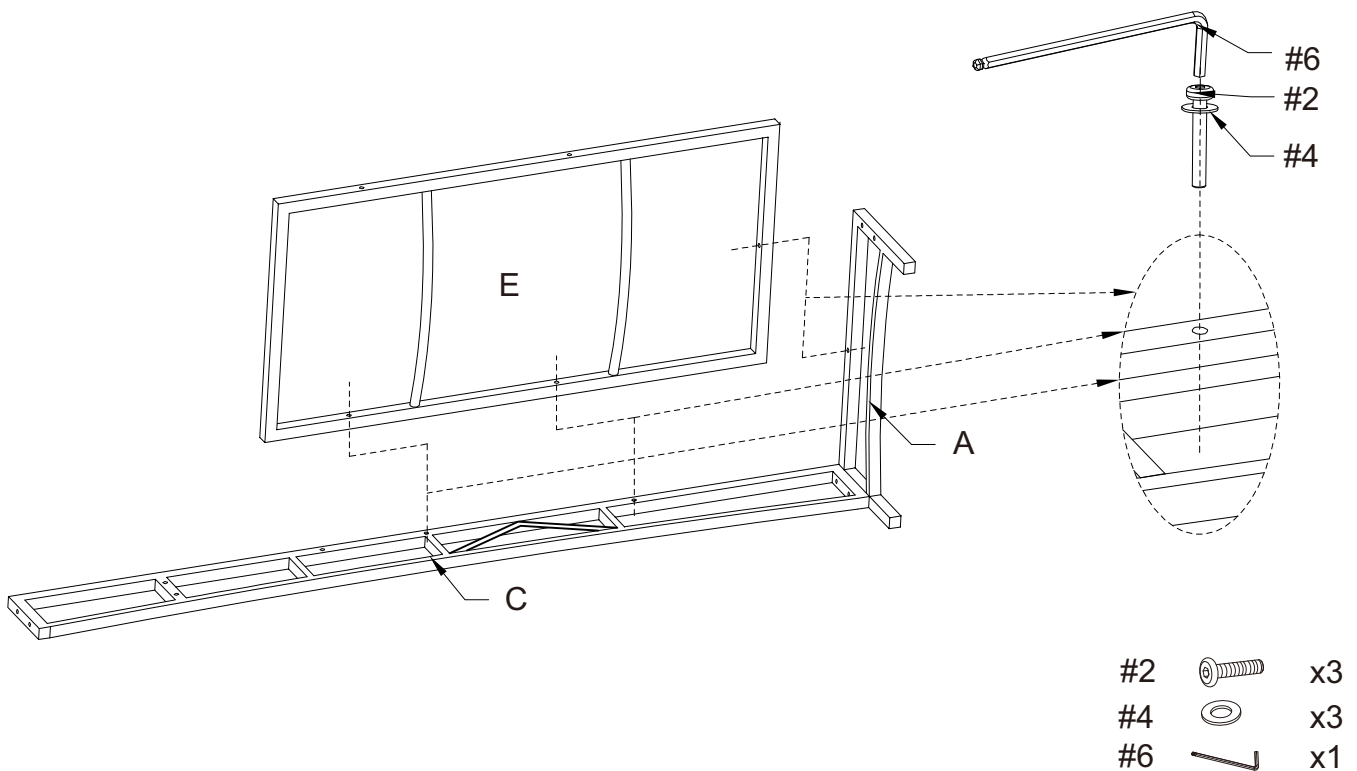

Step 3. Attach back panel (part B) to right side panel (part C) using bolts (part #2), washers (part #4) and allen key (part #6).

NOTE: Please do not fully tighten bolts until unit is fully assembled.

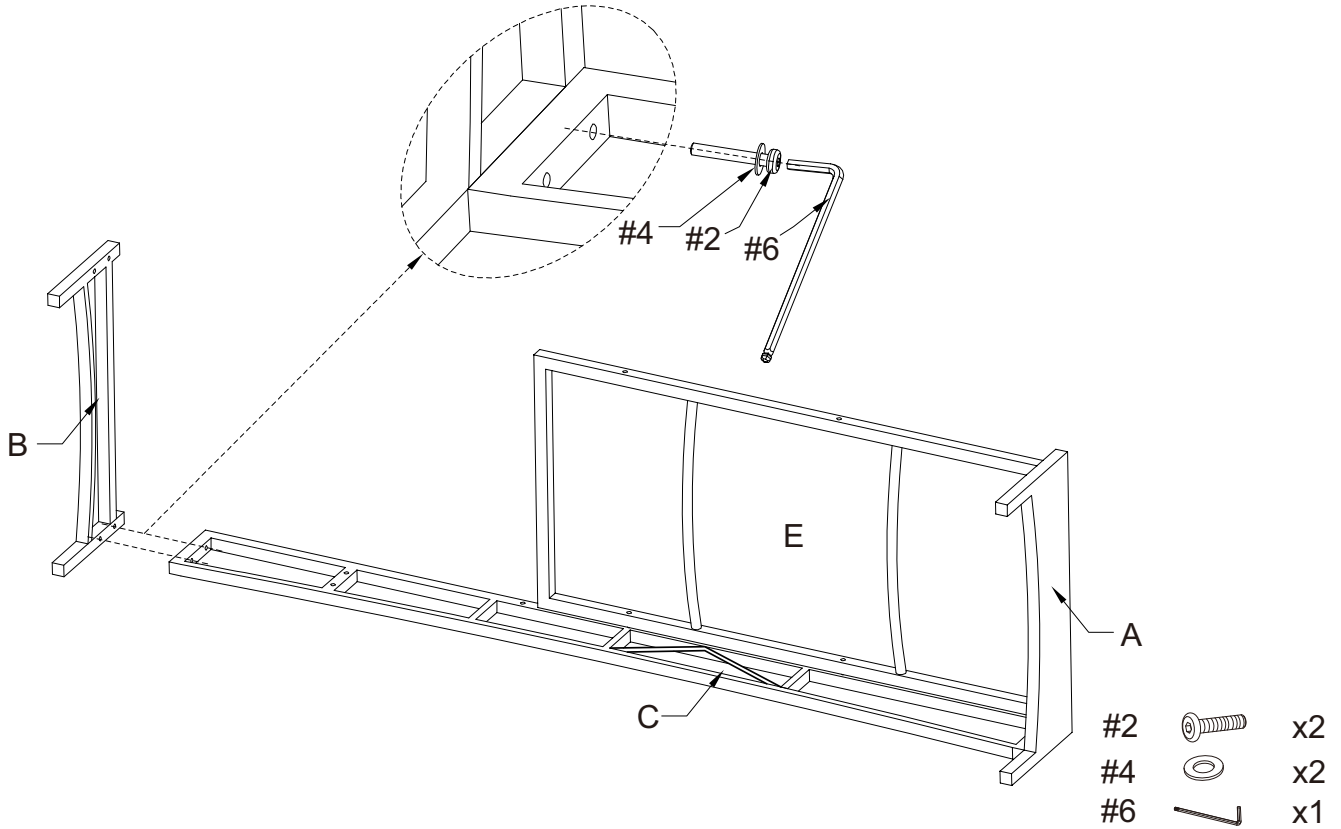

Step 4. Attach left side panel (part D) to front panel (part A), back panel (part B) and seat panel (part E) using bolts (part #2), washers (part #4) and allen key (part #6).

NOTE: Please do not fully tighten bolts until unit is fully assembled.

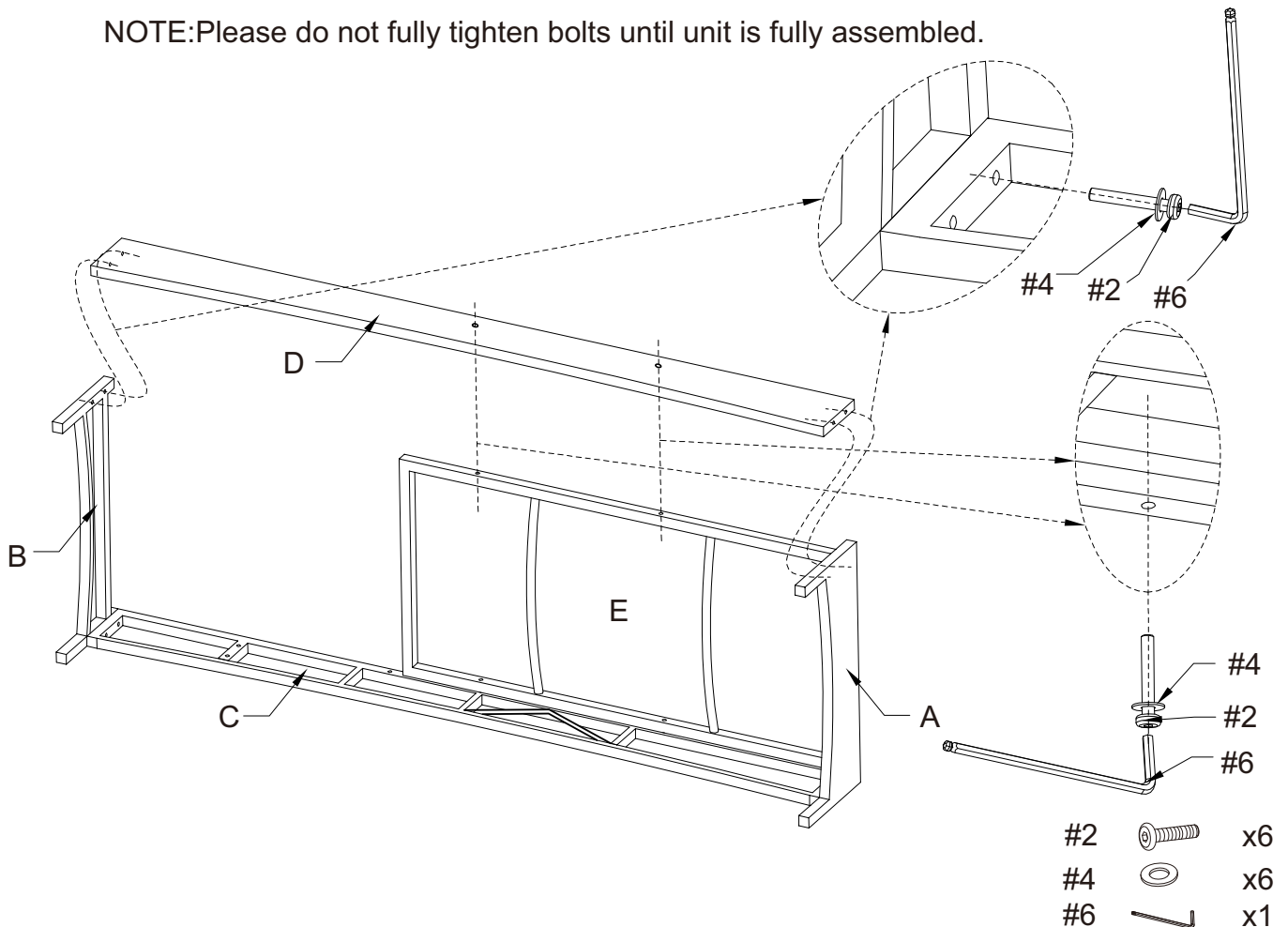

Step 5. Carefully turn assembled unit upright and attach bar (part G) to right side panel (part C) and left side panel (part D) using short bolts (part #1), washers (part #4) and allen key (part #6).

NOTE: Please do not fully tighten bolts until unit is fully assembled.

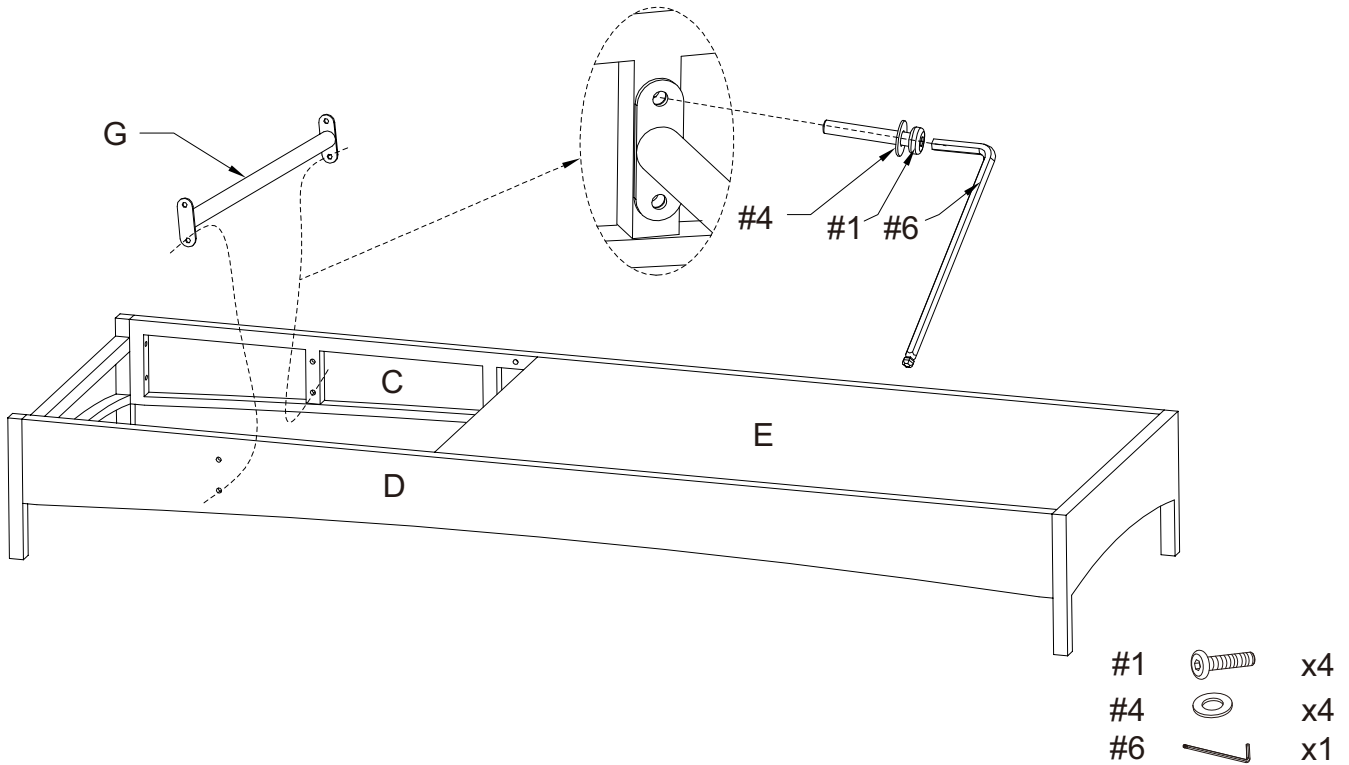

Step 6. Lay the backrest panel (part F) down on a soft flat surface, such as carpet, as shown below. Attach U bar (part H) to backrest panel (part F) using short bolts (part #1), washers (part #4), plastic washers (part #5), nuts (part #3), wrench (part #7) and allen key (part #6).

NOTE: Please do not fully tighten bolts until unit is fully assembled.

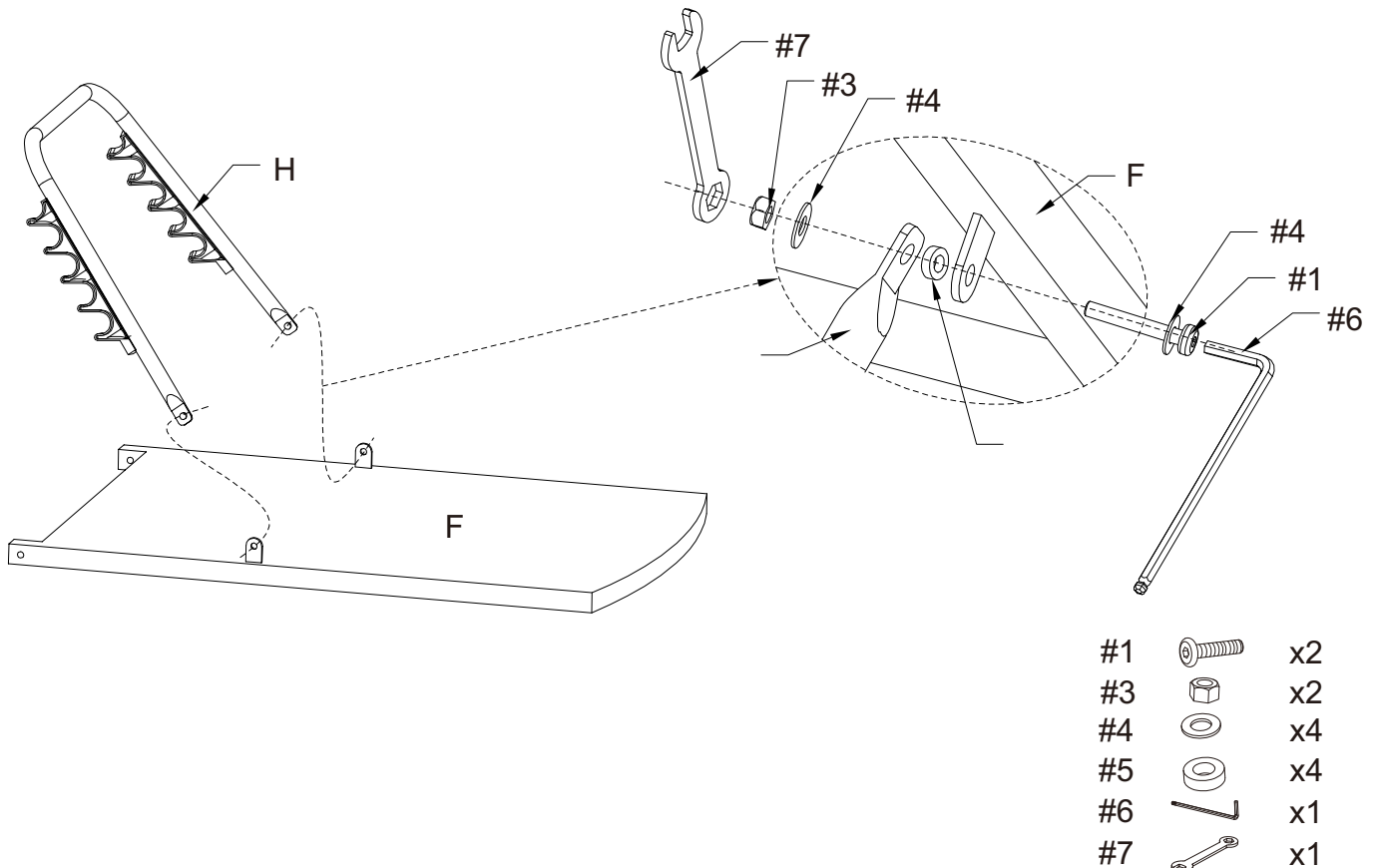

Step 7. Attach the assembled unit (parts F&H) to right side panel (part C) and left side panel (part D) using bolts (part #2), washers (part #4) plastic washers (part #5) and allen key (part #6).

NOTE: Please fully tighten all bolts at this time.

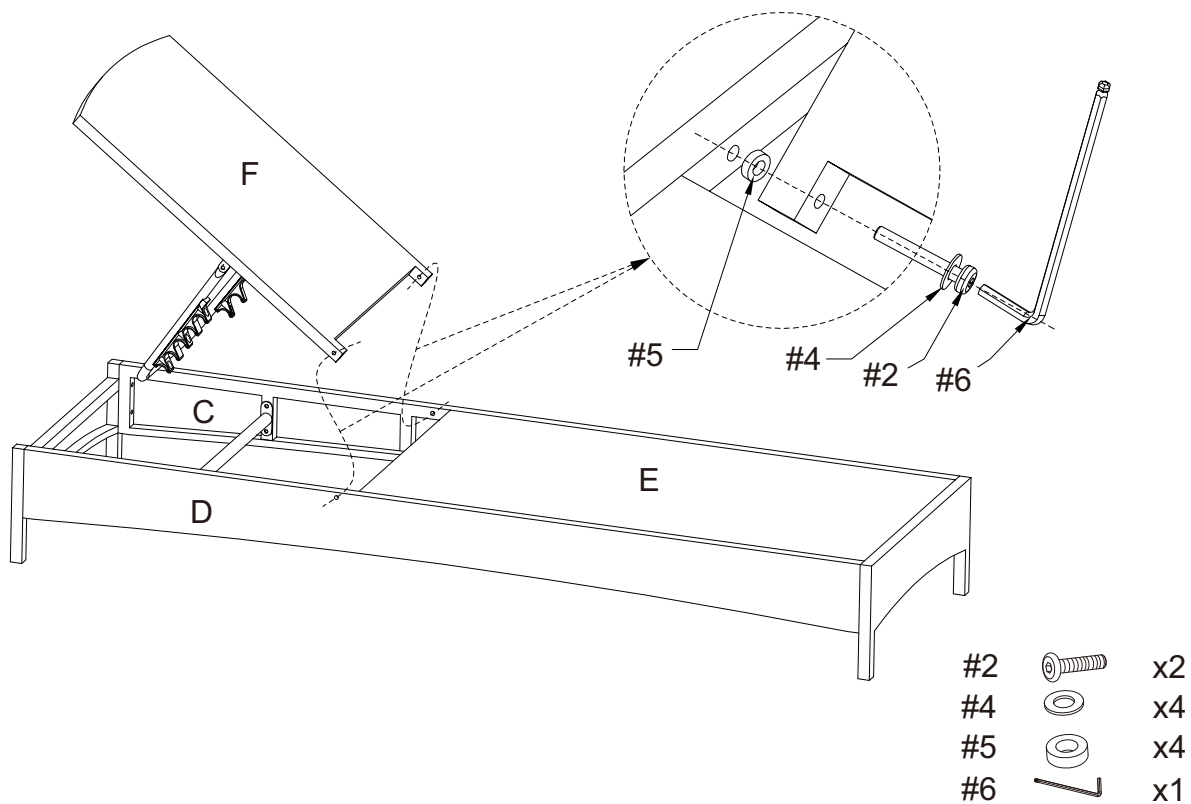

Step 8. Insert core of seat cushion (part J) into cover of cushion (part I).
Insert core of back cushion (part K) into cover of cushion (part I).

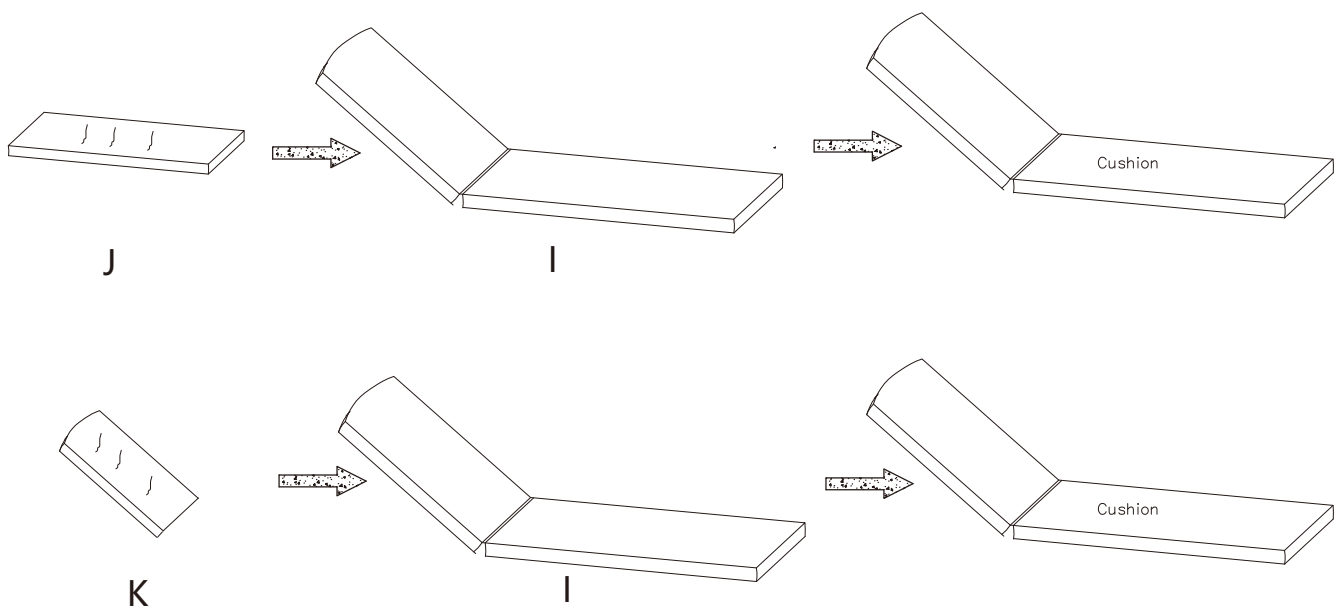

Step 9. Place the cushion (part I) on top of the lounge chair.

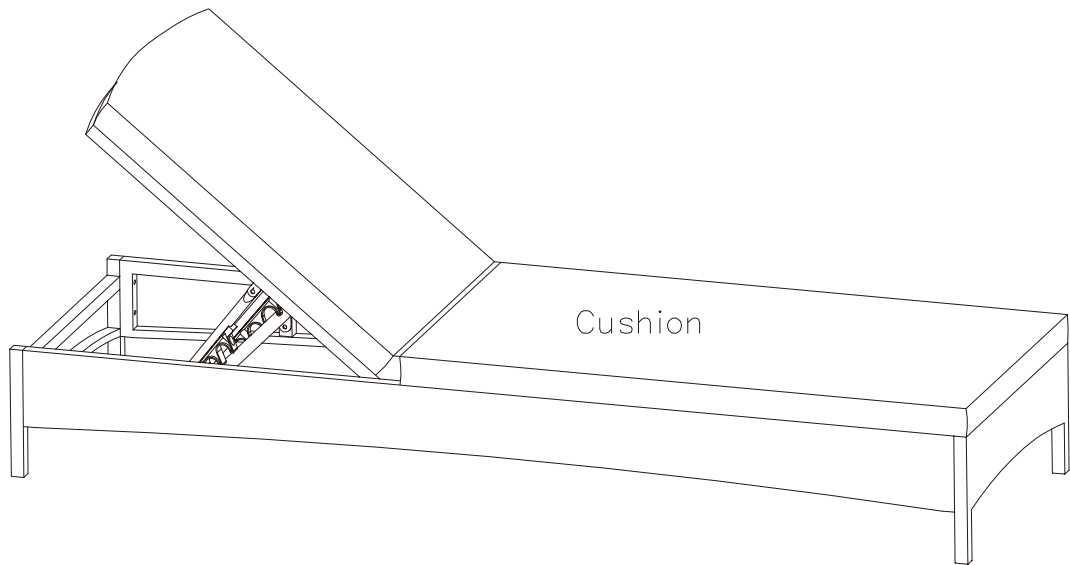

Warning: Please make sure U bar (part H) is fully engaged with bar (part G) before use.

