

# ASSEMBLY INSTRUCTION

## DINING SET

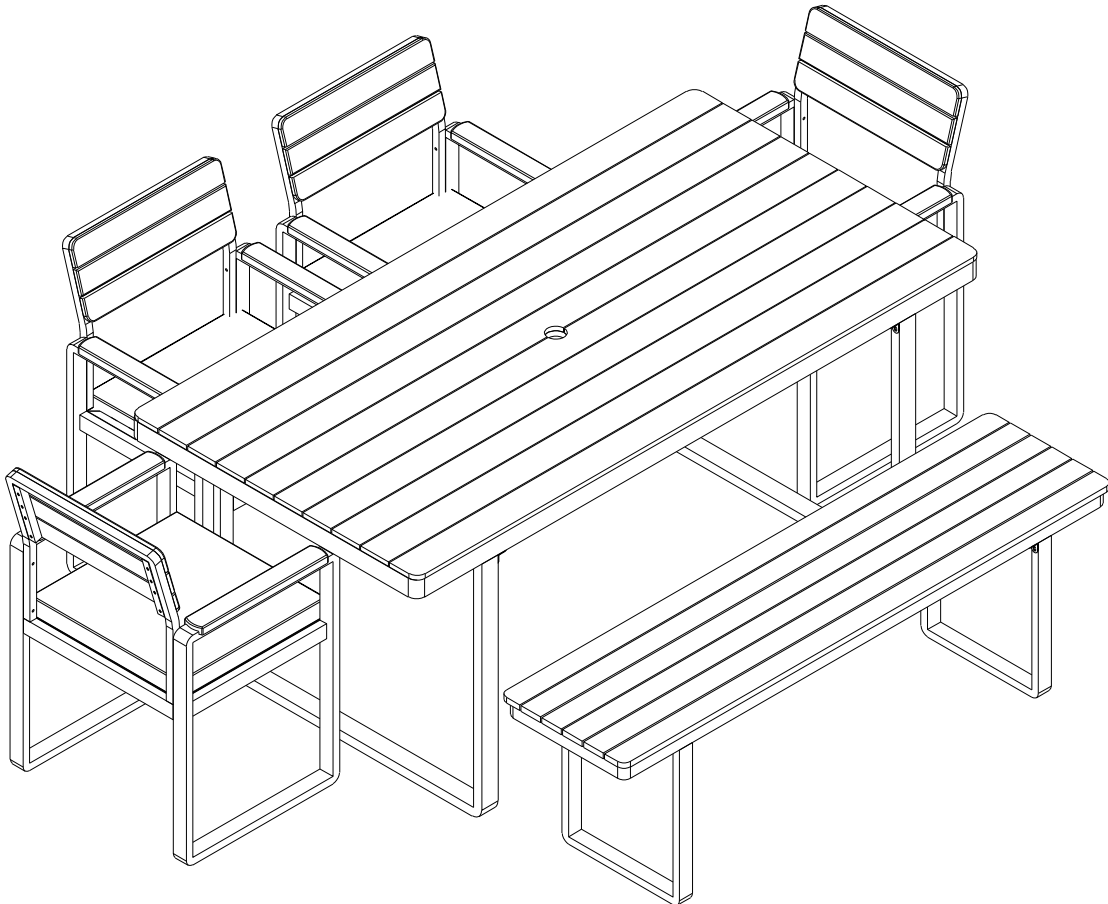

**Notice:**

- 1. 50% Tighten before fixing all screws, Allen wrench is recommended instead of an electric drill.**
- 2. Place the item on a flat ground to adjust and make sure it remains stable.**
- 3. Tighten up all screws with tools gradually.**
- 4. If the screws are not aligned with holes during assembly, please loosen all the other screws to 50% and continue the assembly process.**
- 5. If the item is not stable, please loosen all the screws, adjust it on a flat ground and tighten up all screws again.**
- 6. Note : If one or some screws are fully tightened during assembly, chances are the others will not be aligned with holes. In addition, all the holes are designed to be relatively larger to provide more space for the adjustment of the screws.**

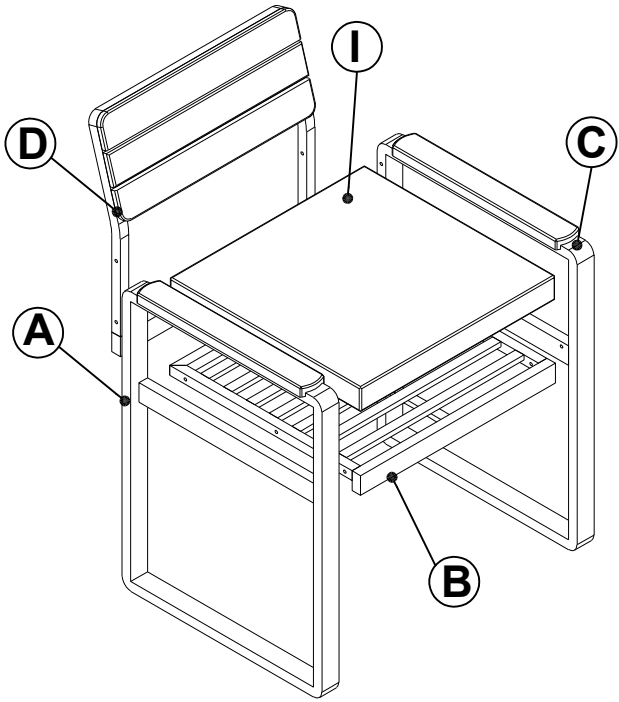

**x4**

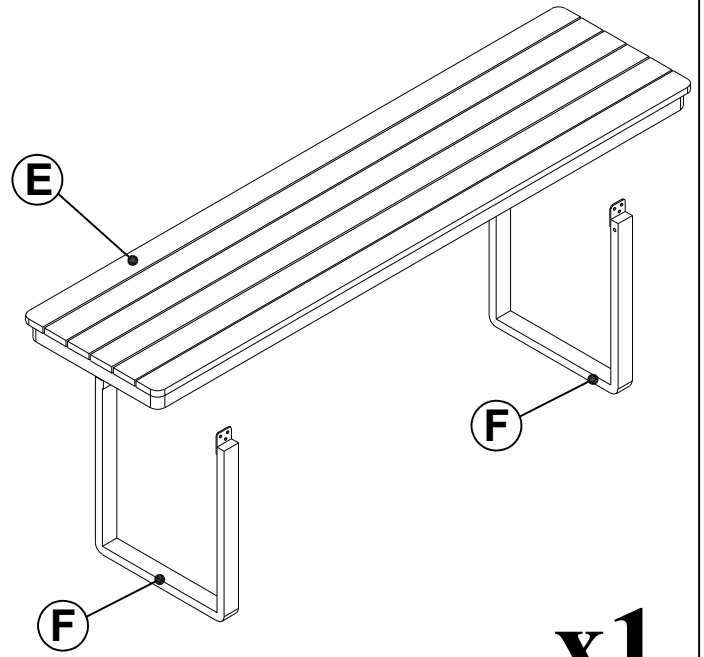



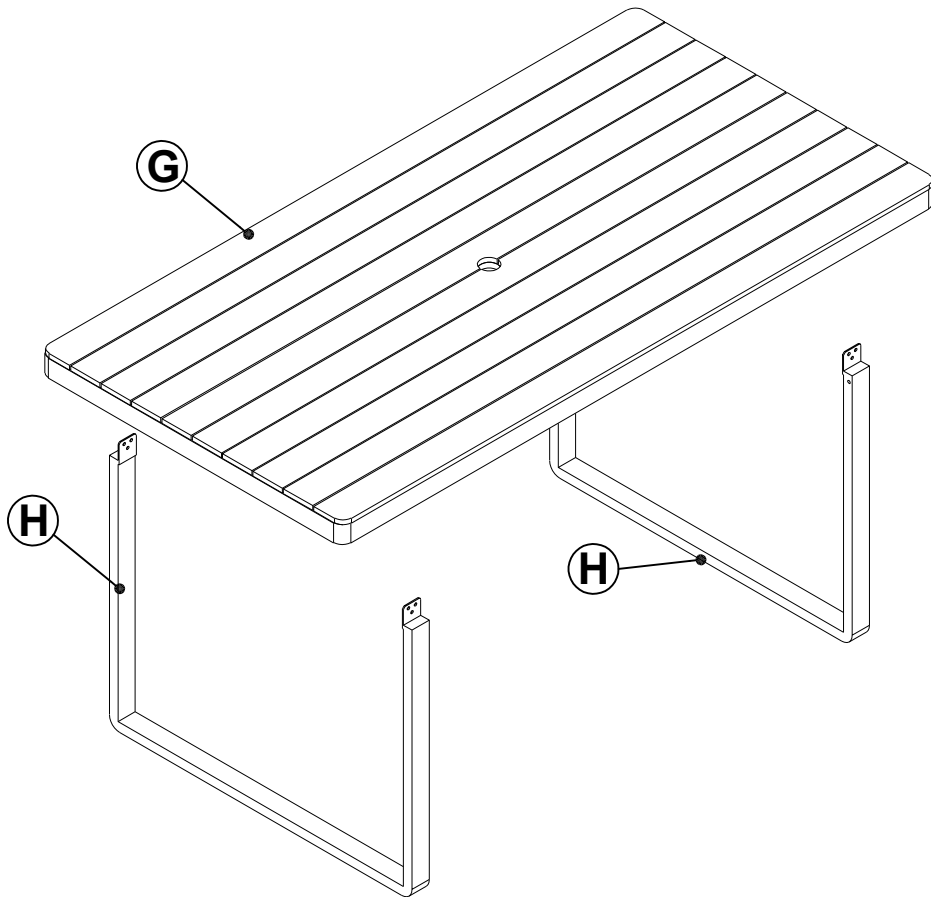

**x1**

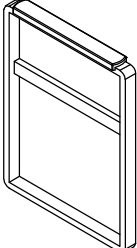
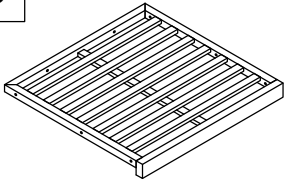
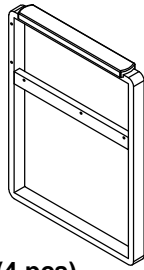
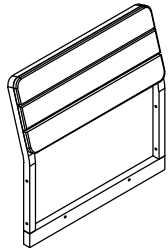
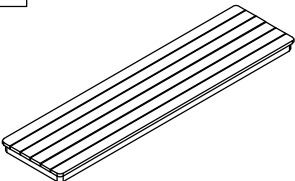
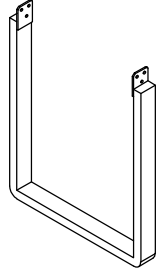
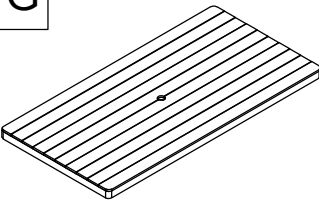
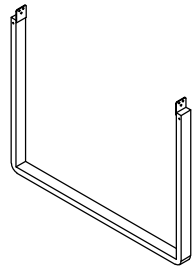
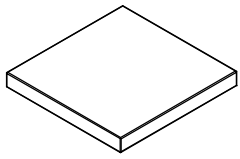

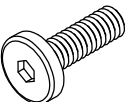
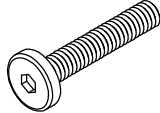
**x1**

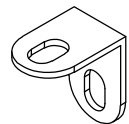
<p><b>A</b></p>  <p><b>Left Leg (4 pcs)</b></p>	<p><b>B</b></p>  <p><b>Seat Chair Frame (4 pcs)</b></p>	<p><b>C</b></p>  <p><b>Right Leg (4 pcs)</b></p>	<p><b>D</b></p>  <p><b>Back Chair Frame (4 pcs)</b></p>
<p><b>E</b></p>  <p><b>Stool (1 pc)</b></p>	<p><b>F</b></p>  <p><b>Stool Leg (2 pcs)</b></p>	<p><b>G</b></p>  <p><b>Table Top (1 pc)</b></p>	<p><b>H</b></p>  <p><b>Table Leg (2 pcs)</b></p>
<p><b>I</b></p>  <p><b>Seat Cushion (4 pcs)</b></p>			

<p><b>1</b> x 40 pcs</p>  <p>Extra 2 pcs BOLT M6 x 20MM</p>	<p><b>2</b> x 48 pcs</p>  <p>Extra 2 pcs BOLT M6 x 35MM</p>	<p><b>3</b> x 88 pcs</p>  <p>Extra 3 pcs Washer M6</p>	<p><b>4</b> x 8 pcs</p>  <p>L Bracket</p>
<p><b>5</b> x 2 pcs</p>  <p>Allen Wrench</p>			

## CARTON CONTENT:

E x1

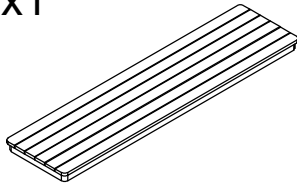

F x2

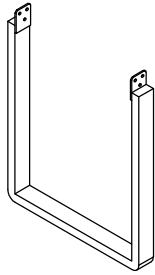

G x1

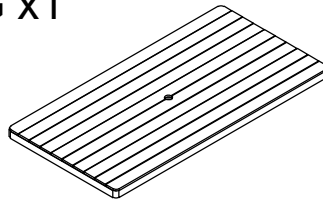

H x 2

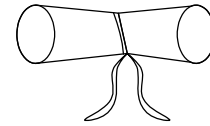
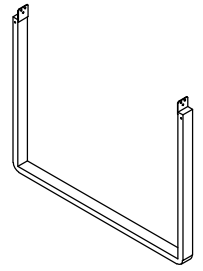

Hardware

Ax4

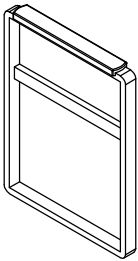

Bx4

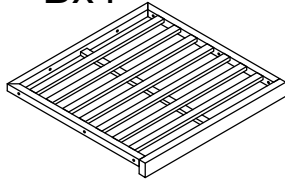

Cx4

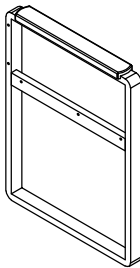

Dx4

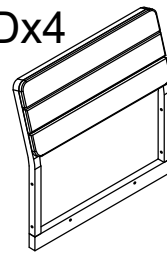

I x4

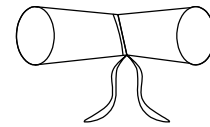
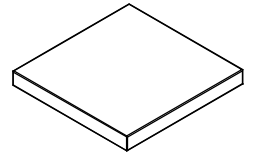

Hardware

## HARDWARE CONTENT

**1** x 40 pcs



Extra 2 pcs  
BOLT M6 x 20MM

**3** x 40 pcs

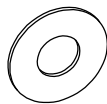

Extra 2 pcs  
Washer M6

**4** x 8 pcs

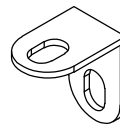

L Bracket

**5** x 1 pc



Allen Wrench

**2** x 48 pcs

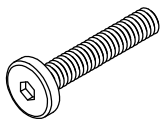

Extra 2 pcs  
BOLT M6 x 35MM

**3** x 48 pcs

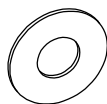

Extra 2 pcs  
Washer M6

**5** x 1 pc



Allen Wrench

**STEP 1**

<b>B</b>	<b>x1</b>
----------	-----------

<b>D</b>	<b>x1</b>
----------	-----------

<b>2</b>	<b>x2</b>
----------	-----------

<b>3</b>	<b>x2</b>
----------	-----------

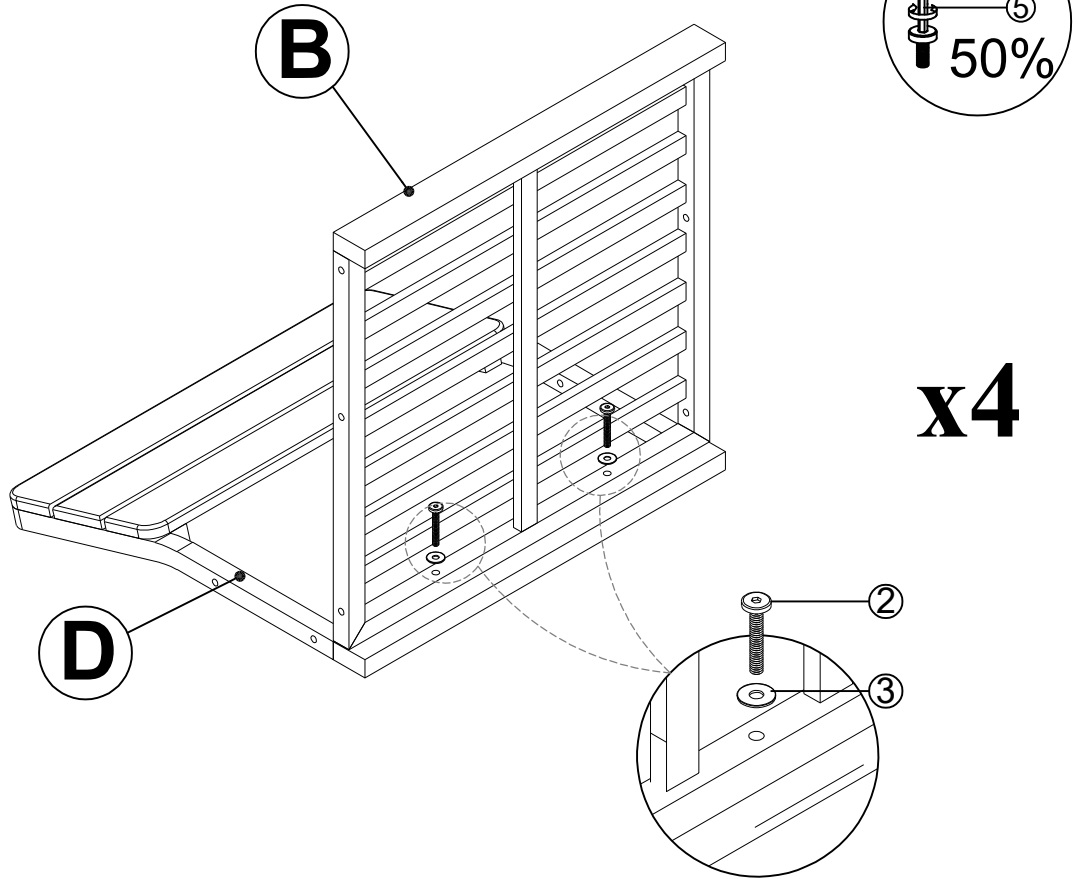

Connect Seat Chair Frame (B) & Back Chair Frame (D), Tighten Bolt (2) & Washer (3) with Allen Wrench (5).

**STEP 2**

<b>C</b>	<b>x1</b>
----------	-----------

<b>2</b>	<b>x3</b>
----------	-----------

<b>3</b>	<b>x3</b>
----------	-----------

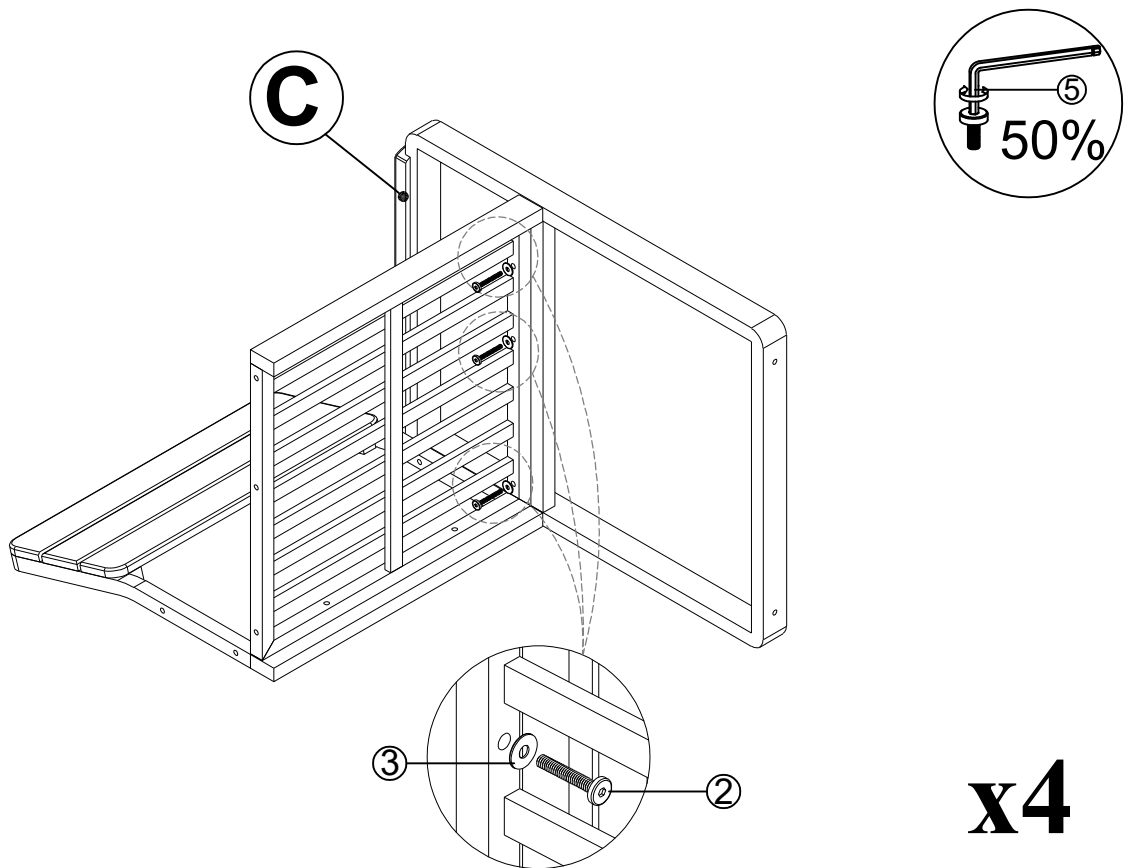

Connect the part from step 1 & Right Leg (C), Tighten Bolt (2) & Washer (3) with Allen Wrench (5).

### STEP 3

<b>A</b>	<b>x1</b>
----------	-----------

<b>2</b>	<b>x3</b>
----------	-----------

<b>3</b>	<b>x3</b>
----------	-----------

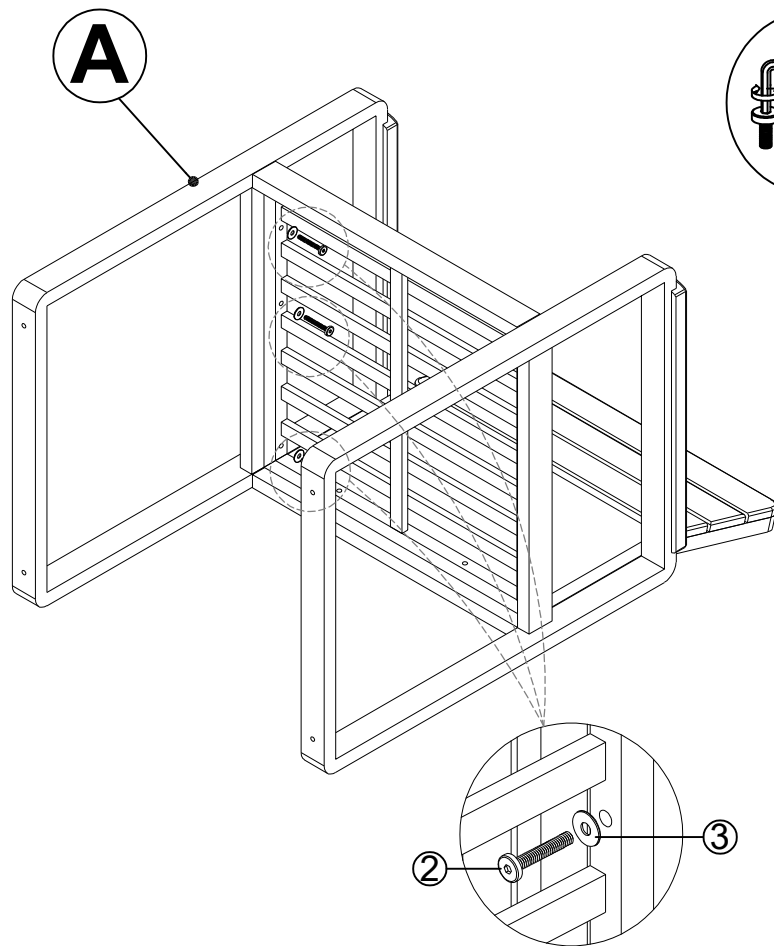

**x4**

Connect the part from step 2 & Left Leg (A), Tighten Bolt (2) & Washer (3) with Allen Wrench (5).

### STEP 4

<b>2</b>	<b>x4</b>
----------	-----------

<b>3</b>	<b>x4</b>
----------	-----------

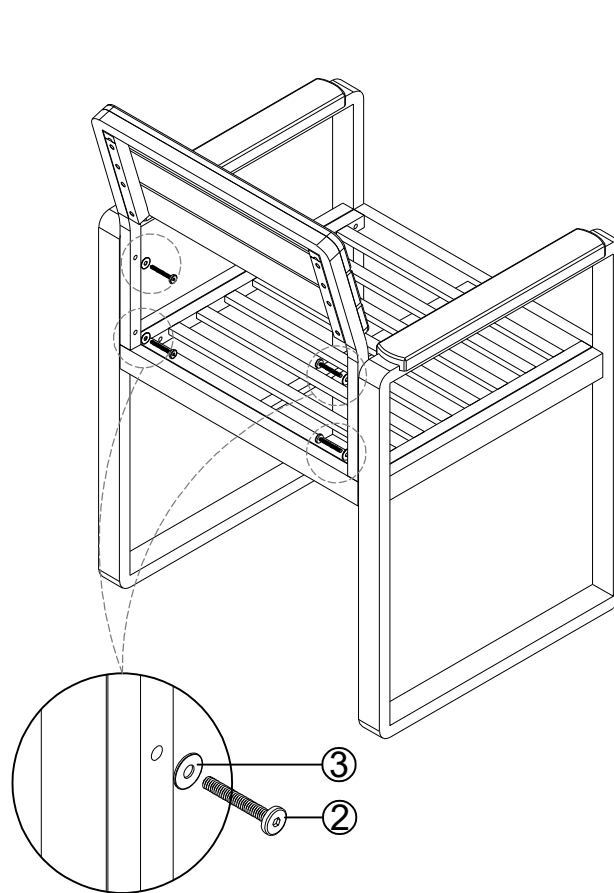

**x4**

Connect the part from step 3 Tighten Bolt (2) & Washer (3) with Allen Wrench (5).

## STEP 5

I	x1
---	----

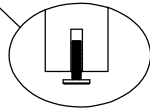
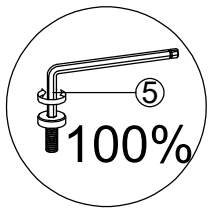
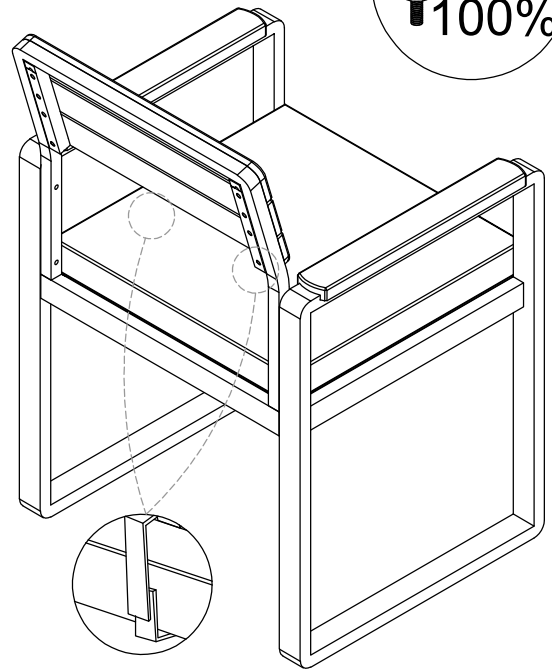
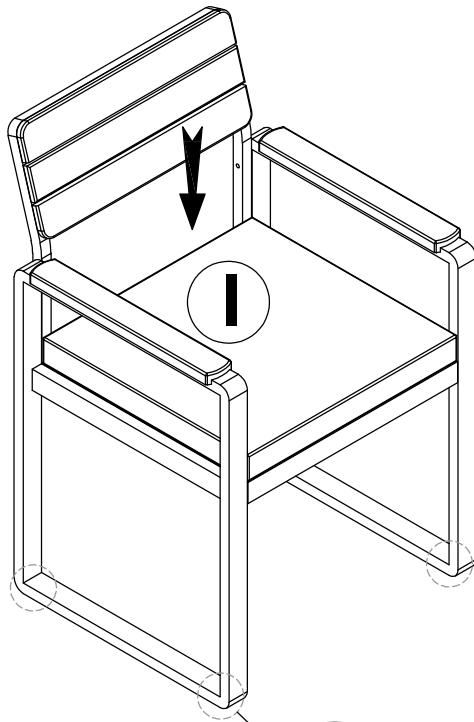

Twist and Adjust height for balance

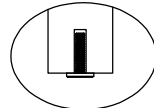

Adjust low for balance

Adjust Pre-installed Levellers height for balance

**x4**

Open all the bags, adjust the cushions & set up the Seat Cushion (I).

## STEP 6

E	x1
---	----

F	x2
---	----

1	x12
---	-----

3	x12
---	-----

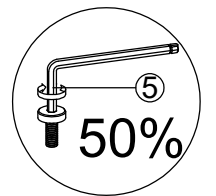
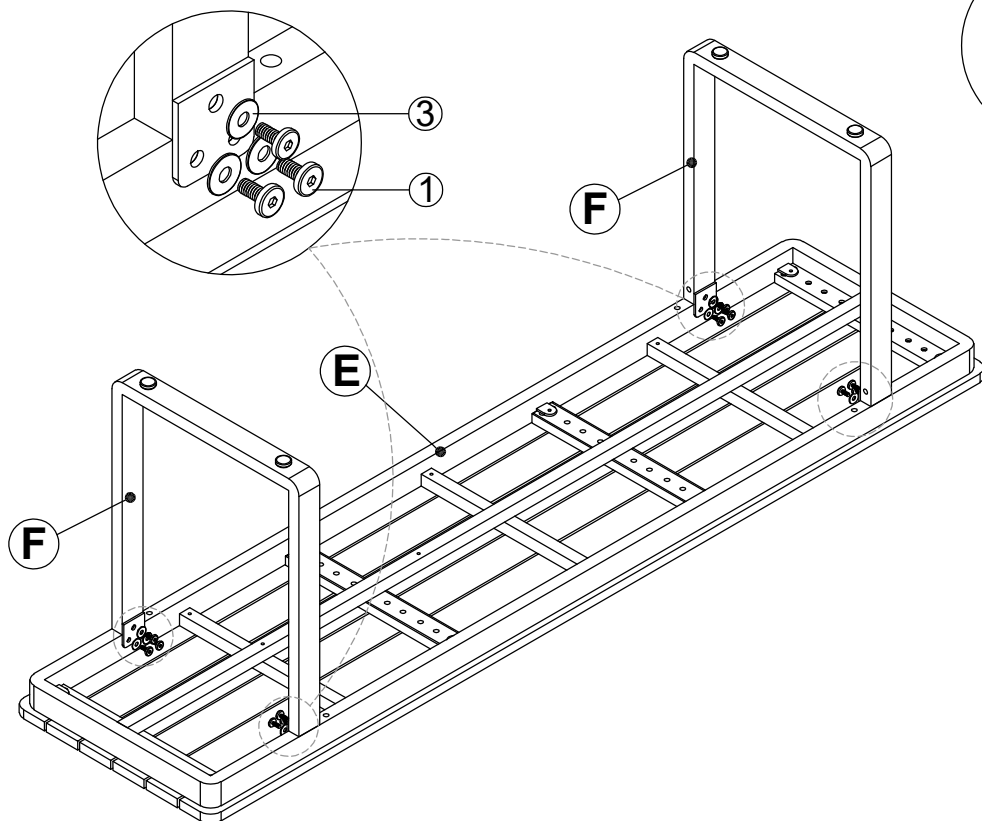

Connect Stool (E) & Stool Leg (F), Tighten Bolt (1) & Washer (3) with Allen Wrench (5).

## STEP 7

1	x8
3	x8
4	x4

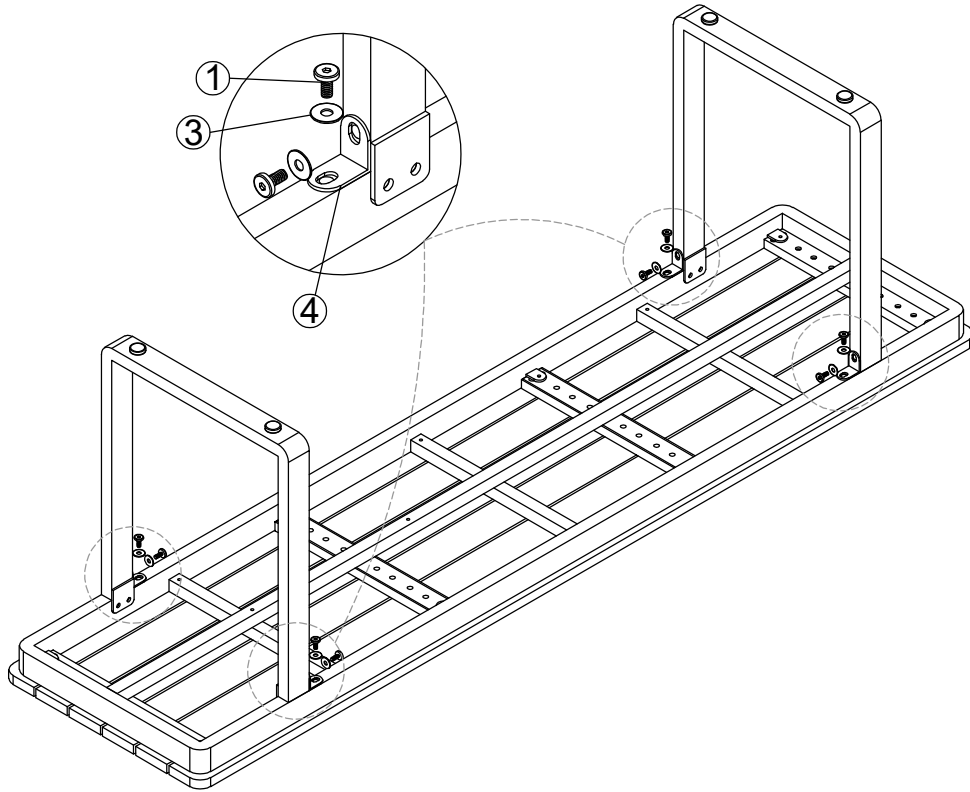

Connect the part from step 6 & L Bracket (4) with Tighten Bolt (1) & Washer (3) with Allen Wrench (5).

## STEP 8

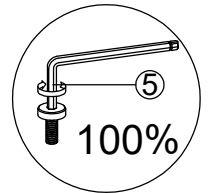
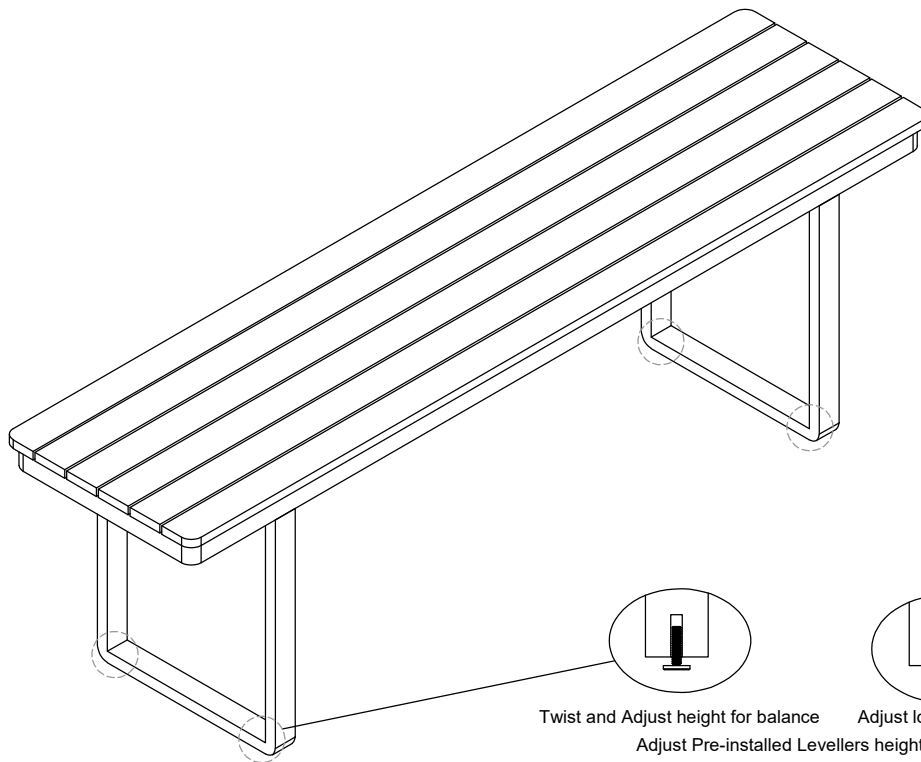

Finish Stool.

## STEP 9

<b>G</b>	<b>x1</b>
<b>H</b>	<b>x2</b>
<b>1</b>	<b>x12</b>
<b>3</b>	<b>x12</b>

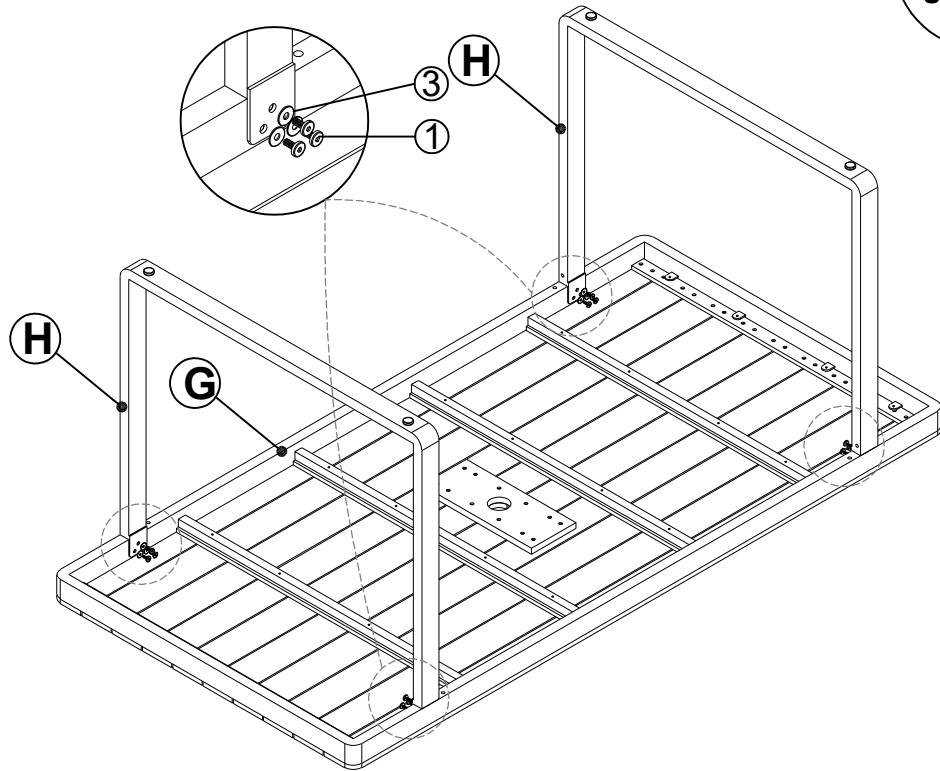

Connect Table Top (G) & Table Leg (H), Tighten Bolt (1) & Washer (3) with Allen Wrench (5).

## STEP 10

<b>1</b>	<b>x8</b>
<b>3</b>	<b>x8</b>
<b>4</b>	<b>x4</b>

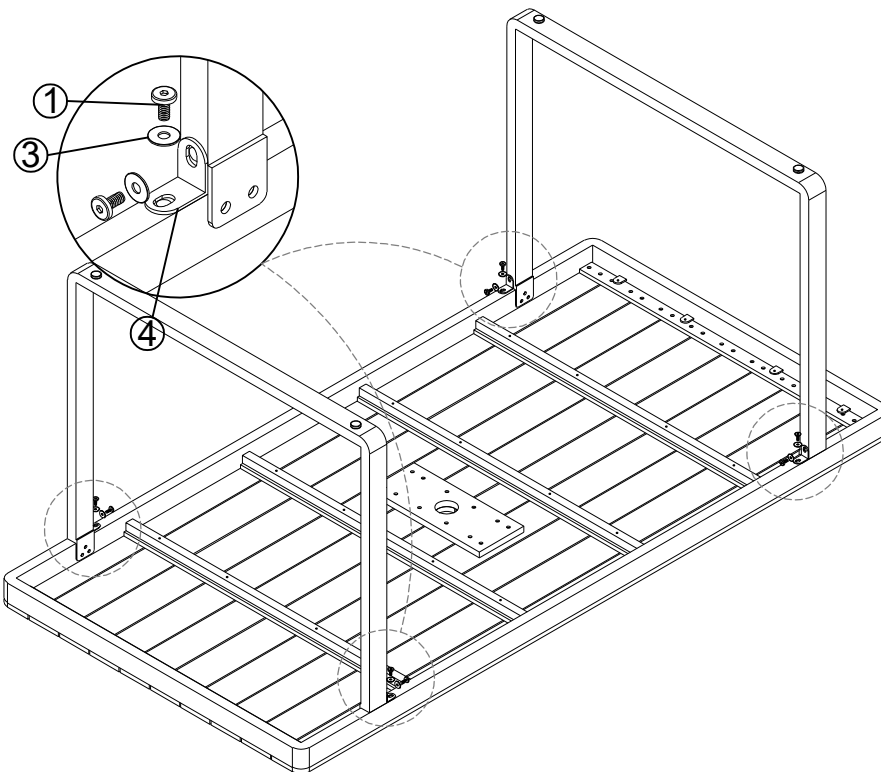

Connect the part from step 9 & L Bracket (4) with Tighten Bolt (1) & Washer (3) with Allen Wrench (5).

# STEP 11

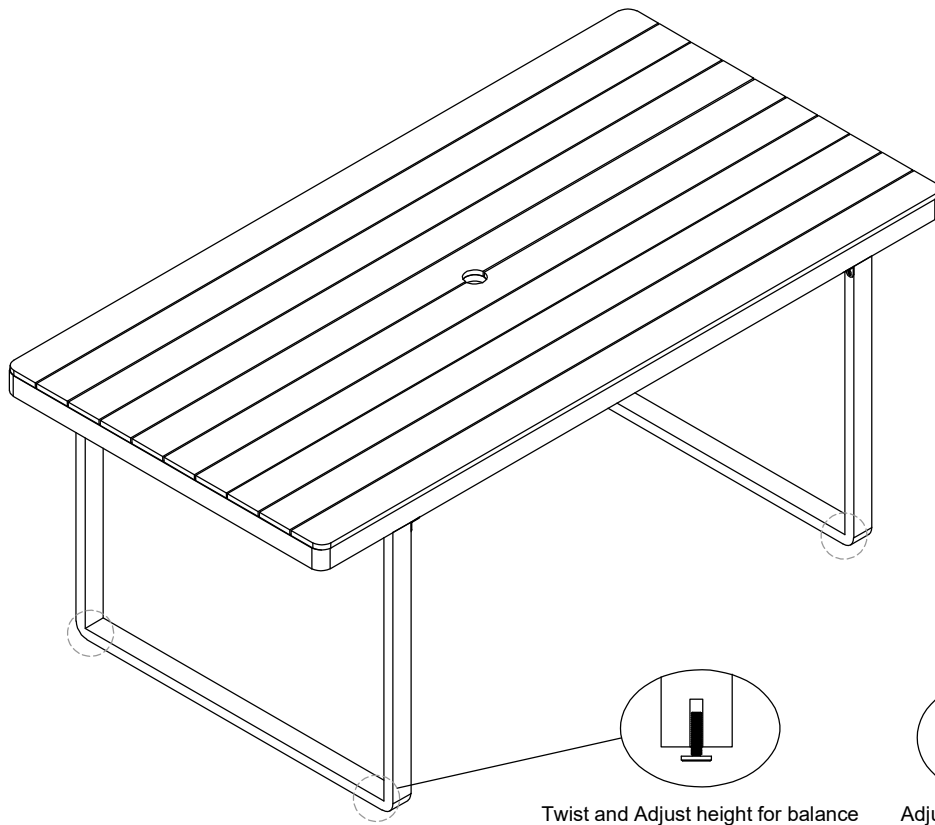
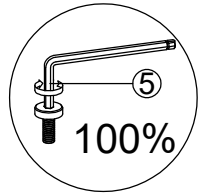

Twist and Adjust height for balance

Adjust low for balance

Adjust Pre-installed Levellers height for balance

Finish Table.

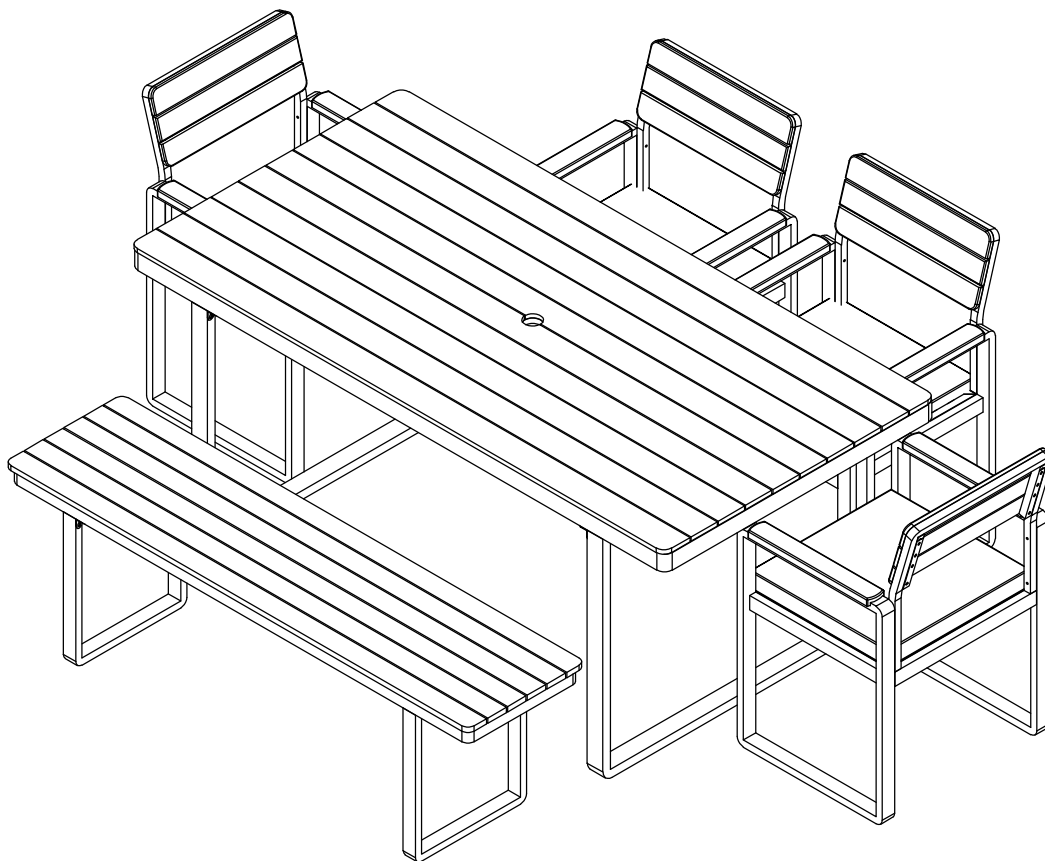

Finish.