

# Natural Expressions

## Sectional Conversation set

### Assembly Instructions

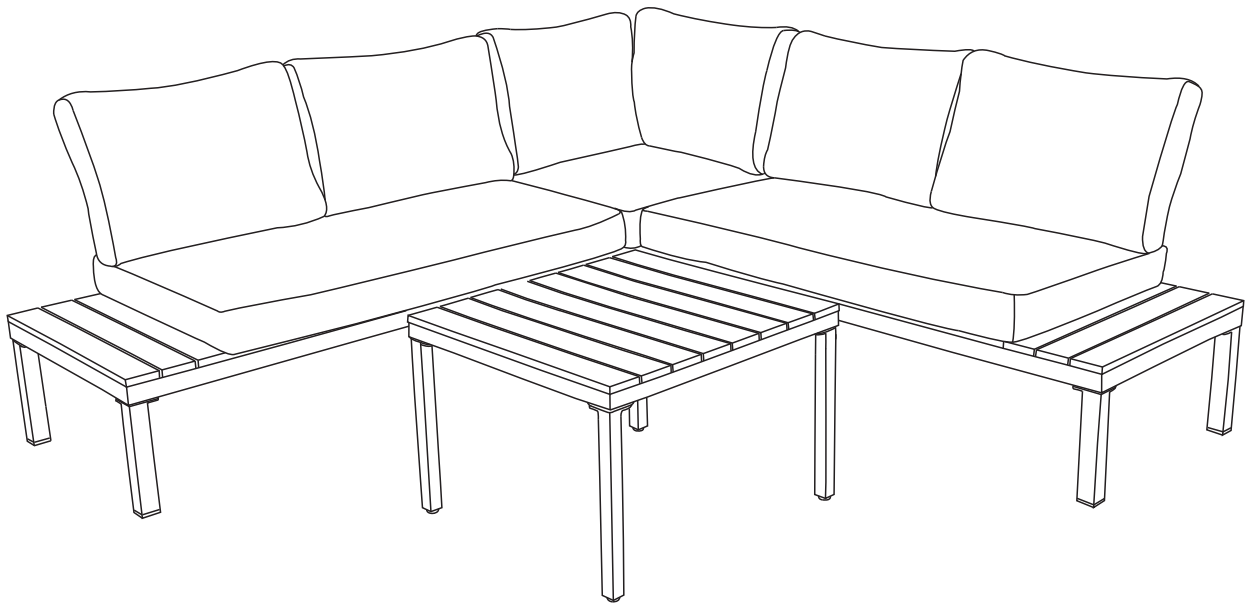







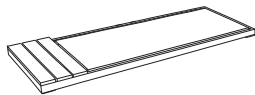
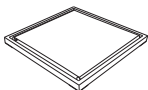

### WARNING

- 1. The 4pcs Sectional Conversation set including 3 boxes  
Please wait one more day if they are not arrive same time*
- 2. Please confirm all parts correct before assemble*
- 3. Do not tighten fastening fully until assembly is complete*
- 4. DO NOT USE POWER TOOLS. Power tools can overtighten screws and strip threads*

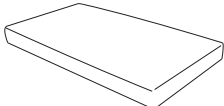
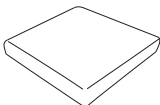
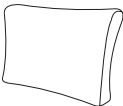
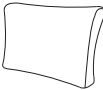
*If you have any questions ,feel free to contact us on amazon*

 **WARNING:** This product can expose you to chemicals including Di(2-ethylhexyl) phthalate (DEHP), which is known to the State of California to cause cancer, and birth defects or other reproductive harm. For more information go to [www.P65Warnings.ca.gov](http://www.P65Warnings.ca.gov).

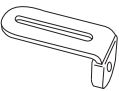
# PARTS LIST

CODE	PARTS	QTY.
A	 DOUBLE SEAT	2PCS
B	 SINGLE SEAT	1PC
C	 BACK	6PCS
D	 LEG (SHORT)	12PCS
E	 SEAT CUSHION-1	2PCS
F	 SEAT CUSHION-2	1PC
G	 BACK CUSHION (LONG)	5PCS
H	 BACK CUSHION (SHORT)	1PC
AA	 BOLT CAP(M6)	36PCS
BB	 BOLT(M6*15)	36PCS
CC	 WASHER(φ 6*12)	36PCS
DD	 SCREW	4PCS
EE	 STEEL PANEL	4PCS
FF	 PLASTIC WASHER (φ 28*5.5)	8PCS
GG	 ALLEN KEY	1PC

1

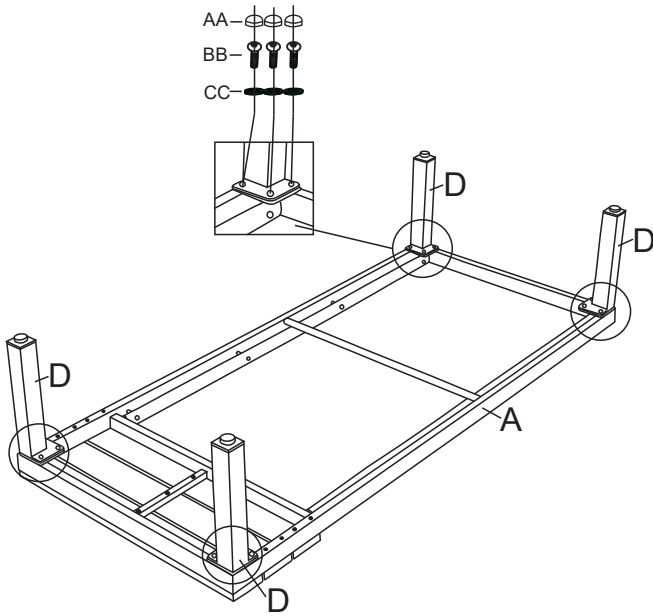

**ATTENTION: Not tighten down until all bolts put in.**

- Attach four seat Legs(D) to the Double Seat(A) by the following diagram and using 3pcs washer (CC), 3pcs bolt (BB), 3pcs bolt caps (AA) for each leg.

2

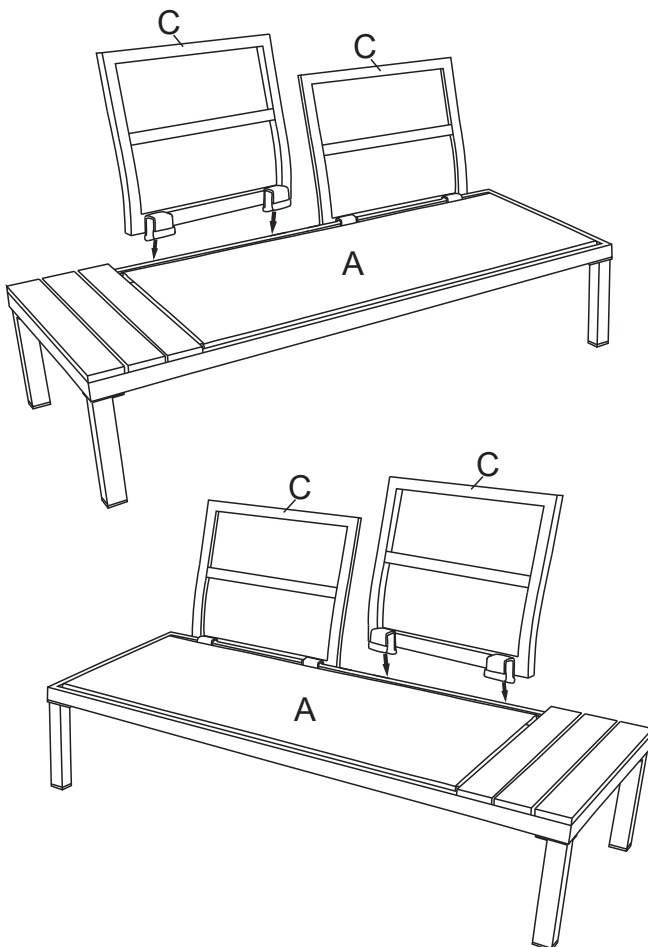

- Clip on two Back panels (C) to the Double Seat (A)

3

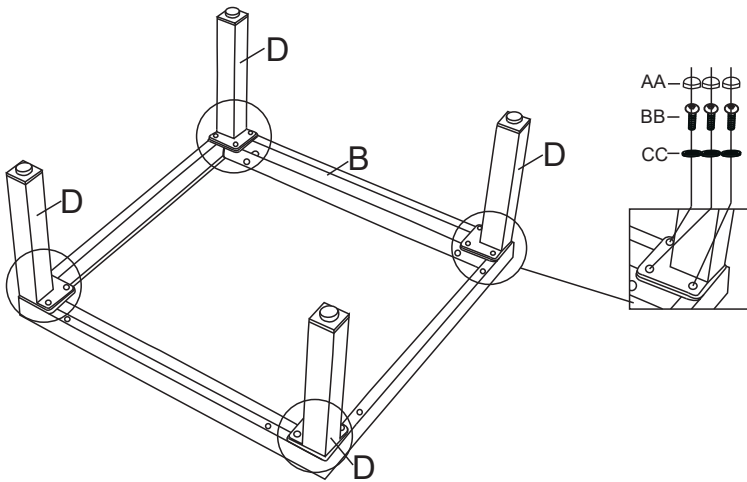

**ATTENTION: Not tighten down until all bolts put in.**

- Attach four Legs(D) to the Single Seat(B) by the following diagram and using 3pcs washer (CC), 3pcs bolt (BB), 3pcs bolt caps (AA) for each leg.

4

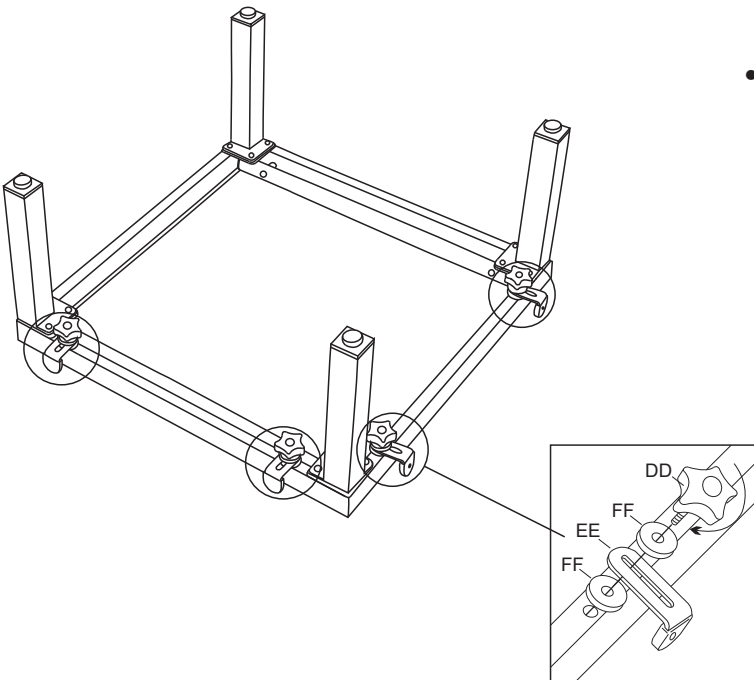

- Attach steel panel (EE), plastic washer (FF), screw (DD) on the seat tube near legs by the following diagram.

5

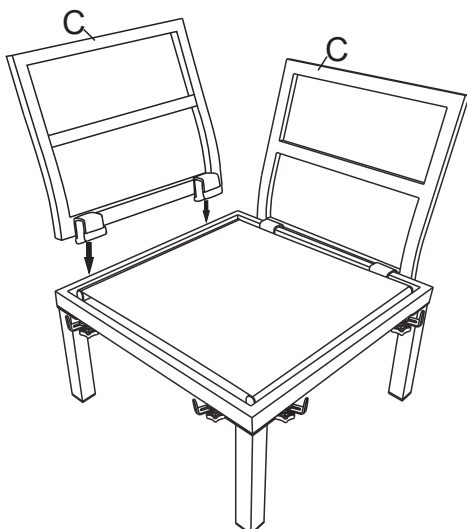

- Attach two Back panels (C) to the Single Seat(B)

1

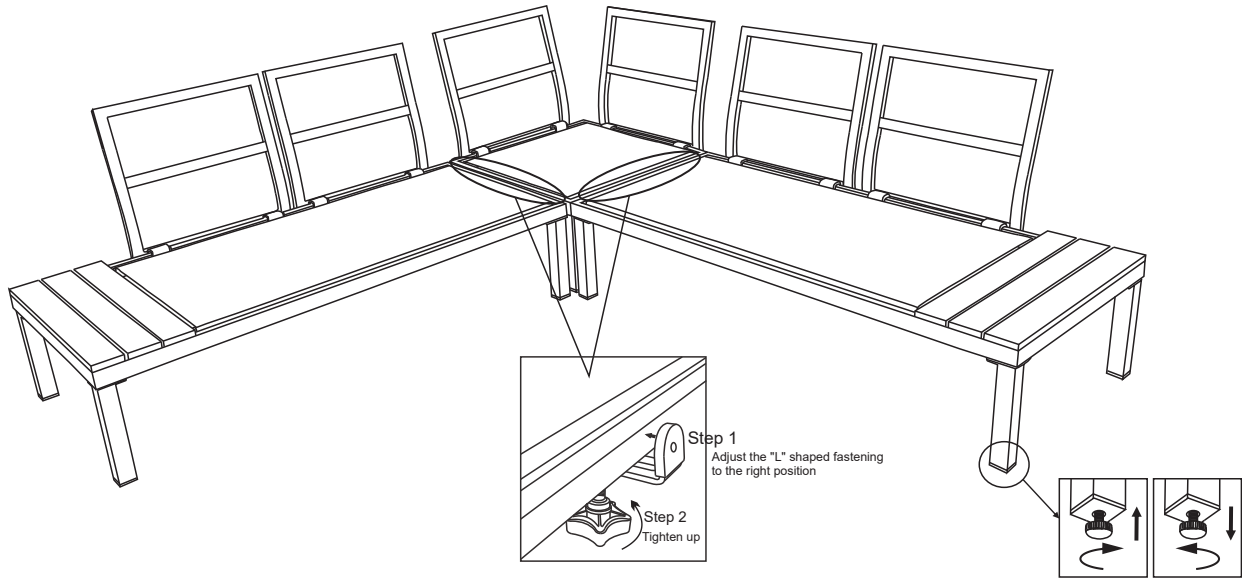



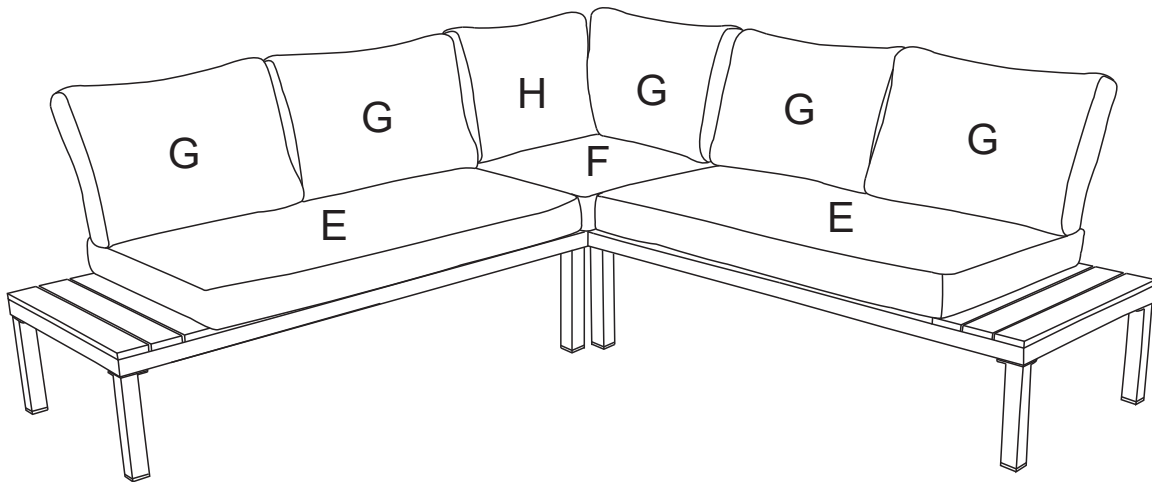

- Connect the Single Seat(B) with Double Seat(A),adjusting "L" shaped steel panel fastening to the right position and tighten the screw up.

2

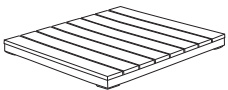

- Place cushions on the chair

# PARTS LIST

CODE	PARTS	QTY.	CODE	PARTS	QTY.
I	 TABLE TOP	1PC	BB	 BOLT(M6*15)	12PCS
J	 LEG (LONG)	4PCS	CC	 WASHER(φ 6*12)	12PCS
AA	 BOLT CAP(M6)	12PCS			

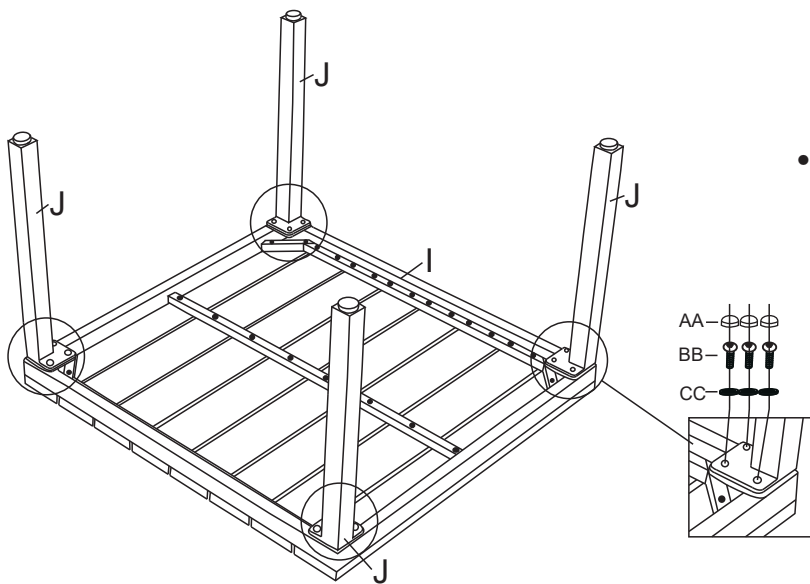

**ATTENTION: Not tighten down until all bolts put in.**

- Attach four table Legs (J) to the table top(I), using 3pcs washer (CC),3pcs bolt (BB), 3pcs bolt caps (AA) for each leg.

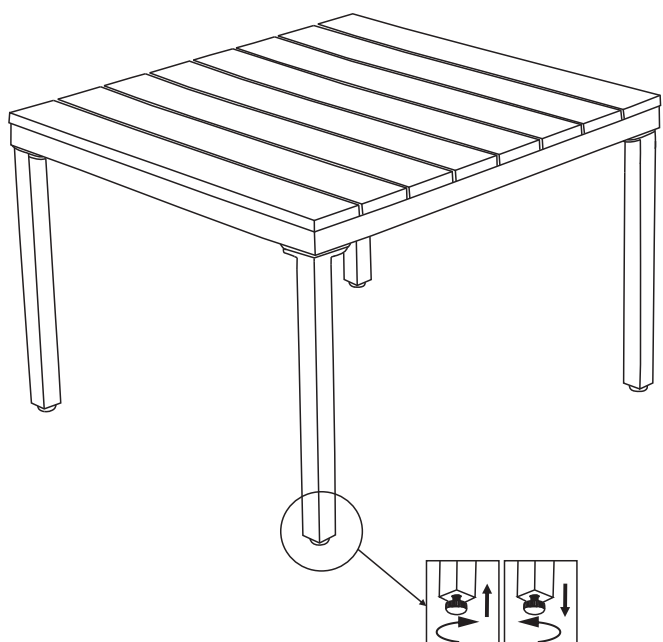

- Leveling table with adjustable foot caps.