

ASSEMBLY INSTRUCTIONS

201-917

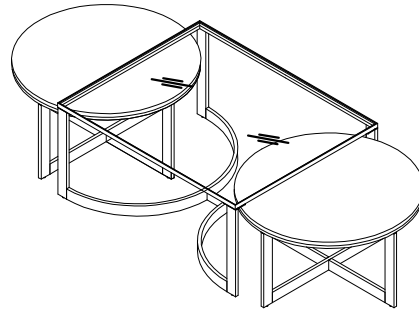

TOOLS REQUIRED:

- Allen Wrench (Provided, Part E)
- ScrewDriver (Not Provided)

BEFORE YOU START:

1. Check the parts against the parts list to make sure all items are present.
2. Assemble your furniture on a soft, flat surface to avoid scratching the finish.
3. **CAUTION:** Do not over tighten screws, nuts or bolts during assembly.
4. Your furniture may require occasional tightening.

INSTRUCTIONS:

NOTE: Assembly is the same for both the large and small table.

1. Turn the table upside down on a clean soft surface.
2. Attach four metal leg to the metal rail using Allen Bolt (B) and the Allen Wrench (E). As Shown in Figure 1. (Do not over tighten bolts during assembly)
3. Attach the metal legs to the top using Bolt (B)/(A), lock washer (C), flat washer (D) and the Allen Wrench (E). As Shown in Figure 2. (Do not over tighten bolts during assembly)
4. Tighten all bolts before setting table back upright.
5. Attach the plastic pad (F) on the top glass bracket. As show in Figure 3.
6. Install the top glass onto the top metal frame.

Figure 1

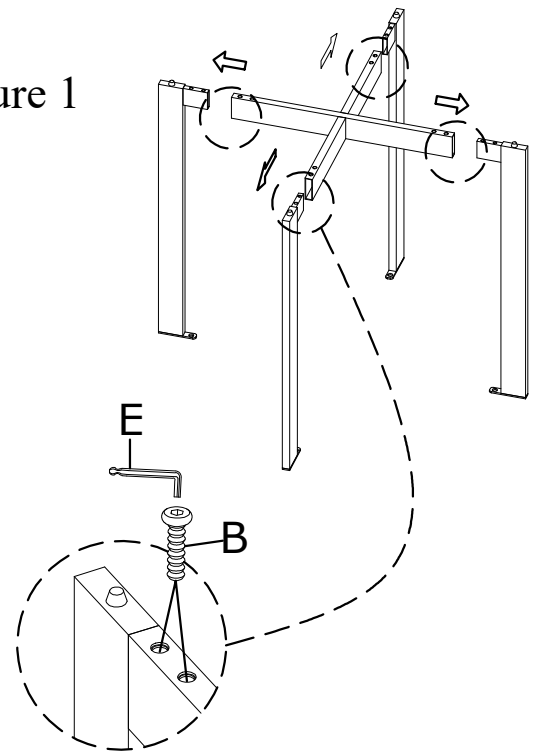
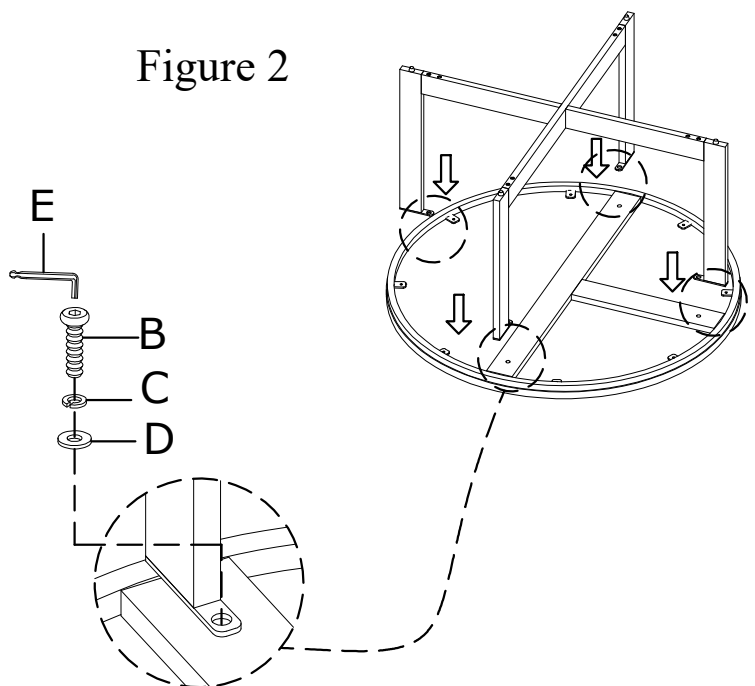

Figure 2



HARDWARE LIST

NO.	Drawing	Description	Q'TY
A		Countersink Bolt (Ø1/4" x 5/8")	12 pcs
B		Allen Bolt (φ1/4 x 5/8")	28 pcs
C		Lock Washer Ø1/4"	8 pcs
D		Flat Washer Ø1/4"*16mm	8 pcs
E		Allen Wrench	1 pc
F		Plastic pad	12 pcs

ASSEMBLY INSTRUCTIONS

201-917

TOOLS REQUIRED:

Allen Wrench (Provided, Part E)

ScrewDriver (No Provided)

BEFORE YOU START:

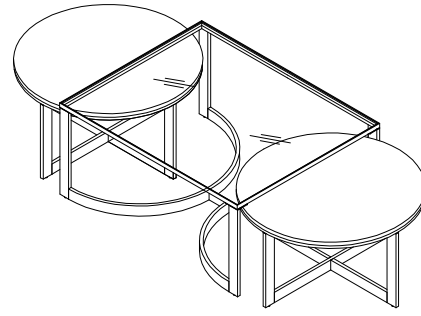

Figure 1

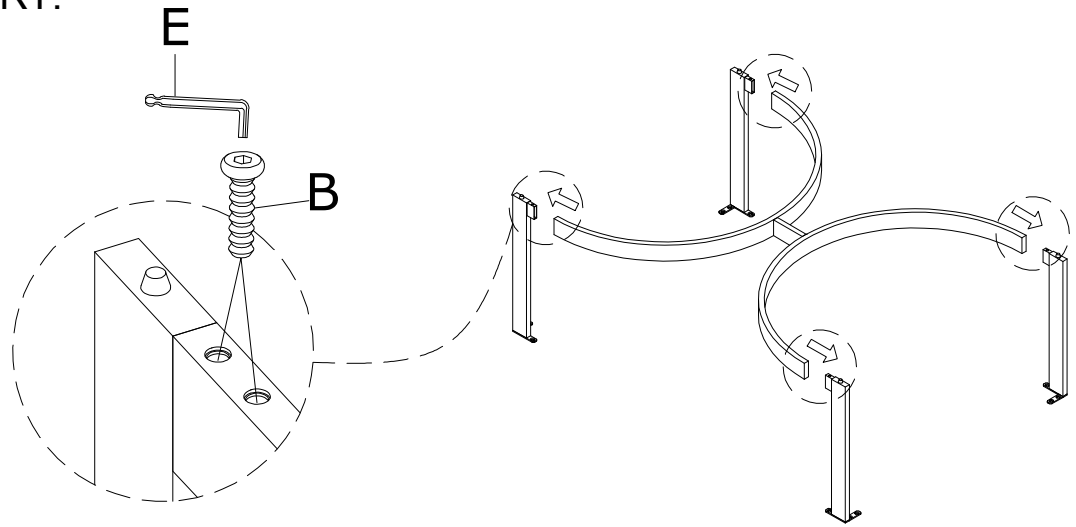

Figure 2

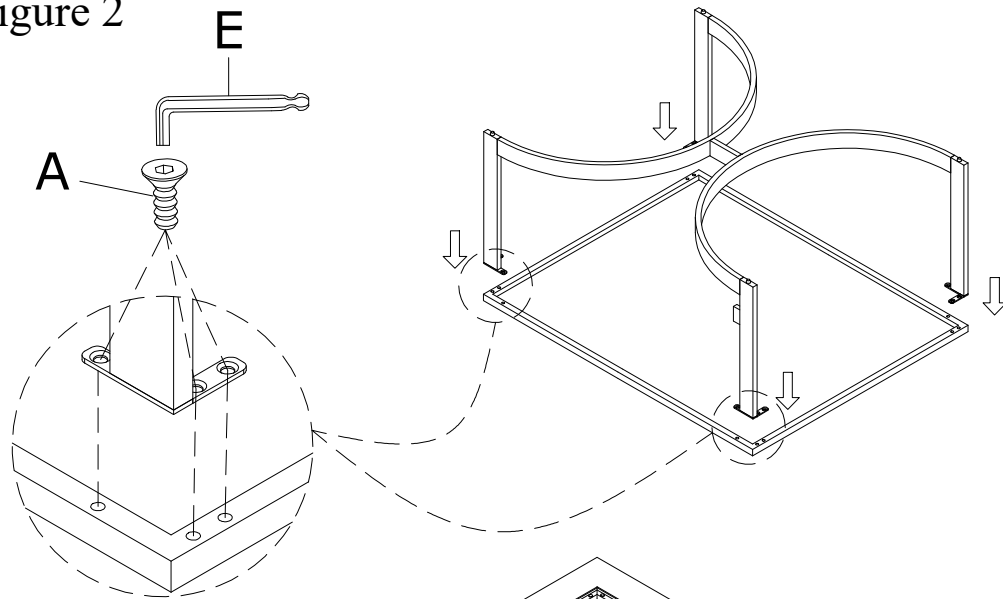

Figure 3

