

# ASSEMBLY AND INSTALLATION INSTRUCTIONS

**WARNING: TO AVOID RISK OF ELECTRICAL SHOCK, BE SURE TO SHUT OFF POWER WHILE INSTALLING OR SERVICING THIS FIXTURE.**

## NOTES:

1. Before installing, consult local electrical codes for wiring and grounding requirements.
2. Read and save these instructions.
3. Always switch off the electricity supply and allow to cool for 10 minutes before changing the light bulbs.

## 1-LIGHT WALL SCONCE

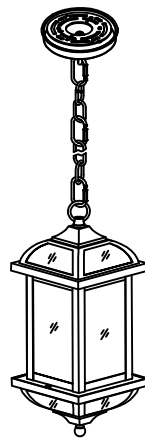

### TOOLS REQUIRED

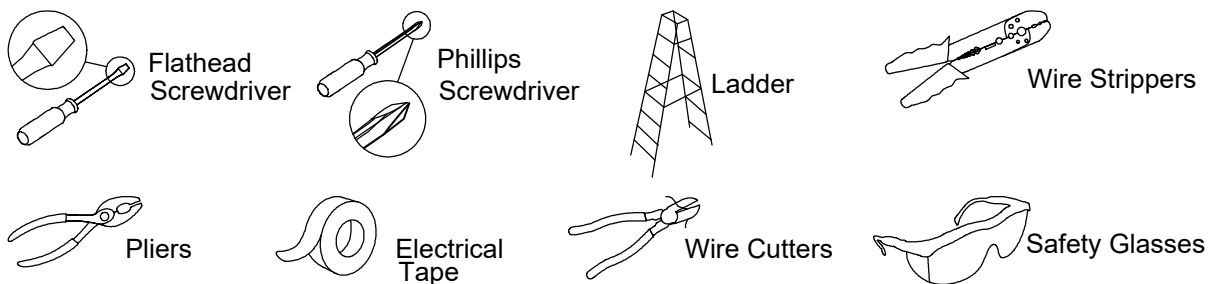

### PREPARATION

Before beginning assembly of product, make sure all parts are present. Compare parts with package contents list and hardware contents list. If any part is missing or damaged, do not attempt to assemble the product. When the lamp is not installed finish, please don't throw away the package, so as not to leave the parts in the package.

## PART LIST AND HARDWARE LIST

PIECE	DESCRIPTION	QUANTITY
A	Wire nut	3
B	Mounting plate	1
C	Green ground screw	1
D	Outlet box screw	2
E	Suction Disk	1
F	Decorative Nuts	2
G	Open Lock Ring	3
H	Chain Sling	1
I	Fixture body	1
L	Screw	2
M	Bottom	1

## INSTALLATION

1. Fix the installation board (B) onto the junction box with the outlet box screws (D).
2. Install A-type light bulbs with a maximum power of 60W on the lamp head (not included).
3. Attach the bottom cover (M) onto the clamp (I) and tighten it with two screws (L).
4. Use three open locking buckles (G) to connect the clamp (I), suspension chain (H), and suction cup (E) together.
5. Connect the grounding wire (green or bare copper wire) of the power supply circuit to the fixed grounding wire, with the black wire connected to (black) and the white wire connected to (white).
6. Insert the suction cup (E) into the mounting plate (B) and lock it with the decorative nut (F).

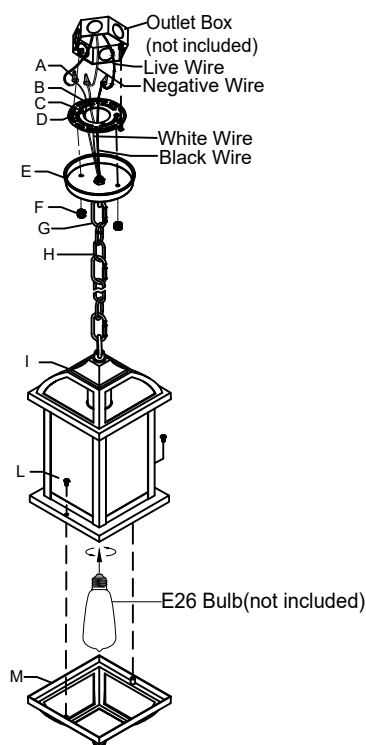

If you have any issues with use this product, please email us. Be sure to include your order number and photos of the issues. This will help us provide you with faster support and solve your problem.