

Weight capacity : 75 kgs/ 165 Lbs

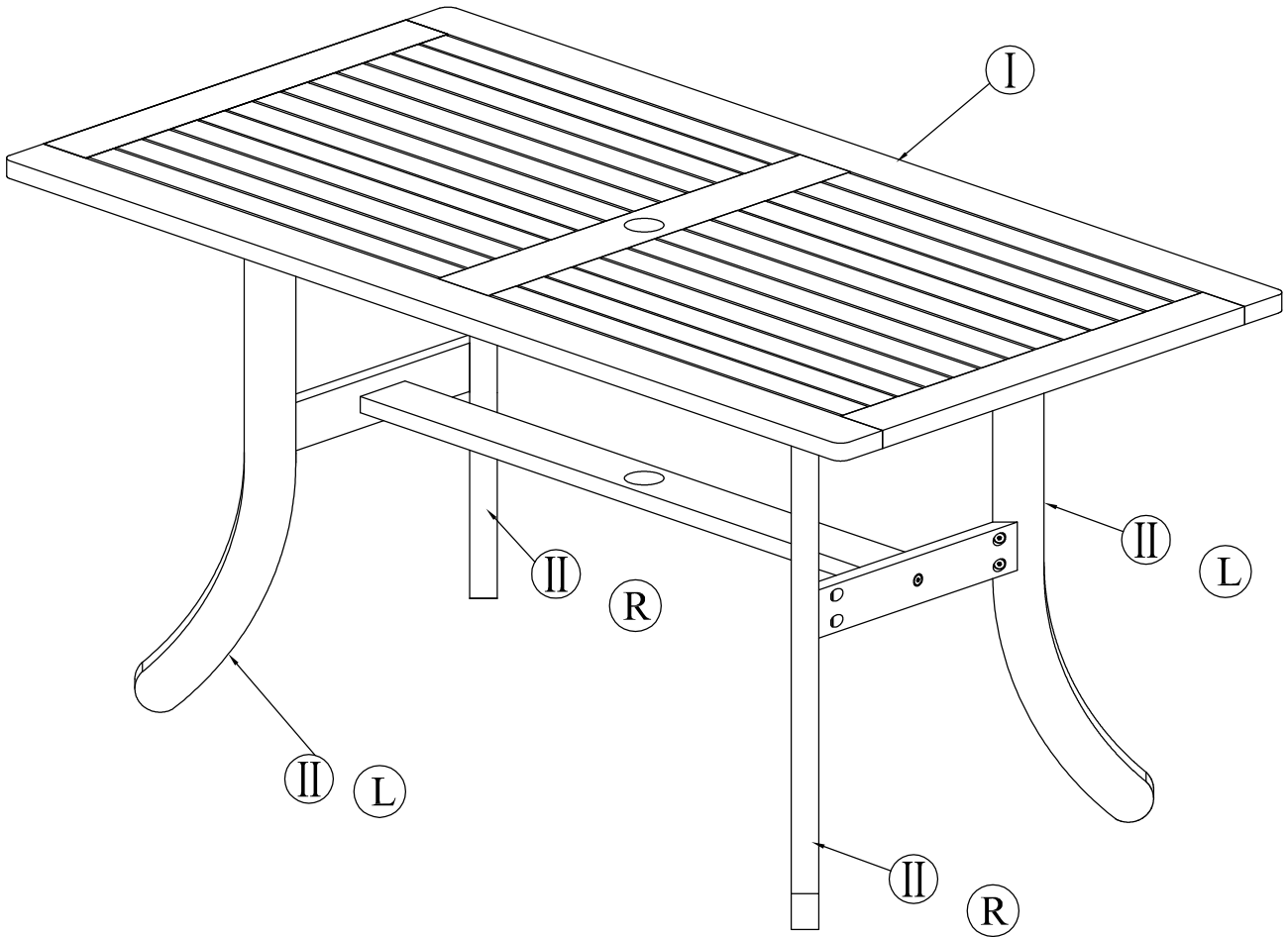





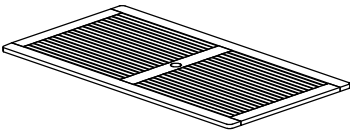
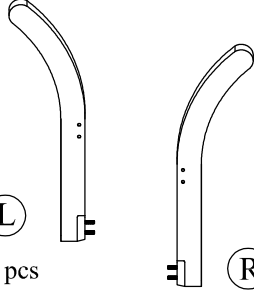
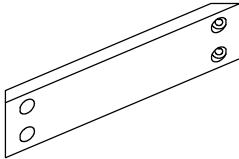
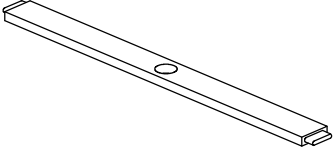

NOTE: 50% TIGHTEN BEFORE FIXING ALL BOLTS & SCREWS

COMPONENTS LIST

<p>Ⓘ</p>  <p>Q'TY 1</p>	<p>Ⓜ</p>  <p>Ⓛ 2 pcs</p> <p>Ⓡ 2 pcs</p> <p>Q'TY 4</p>	<p>ⓂⓂ</p>  <p>Q'TY 2</p>	<p>ⓂⓂⓂ</p>  <p>Q'TY 1</p>
---	--	--	--

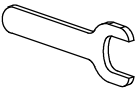
HARDWARE LIST

A		2	Screw 7 x 60	D		8	Washer
B		8	Screw 7 x 40	E		1	Spanner
C		8	Nut M8	F		2	Allen Key

Step 1

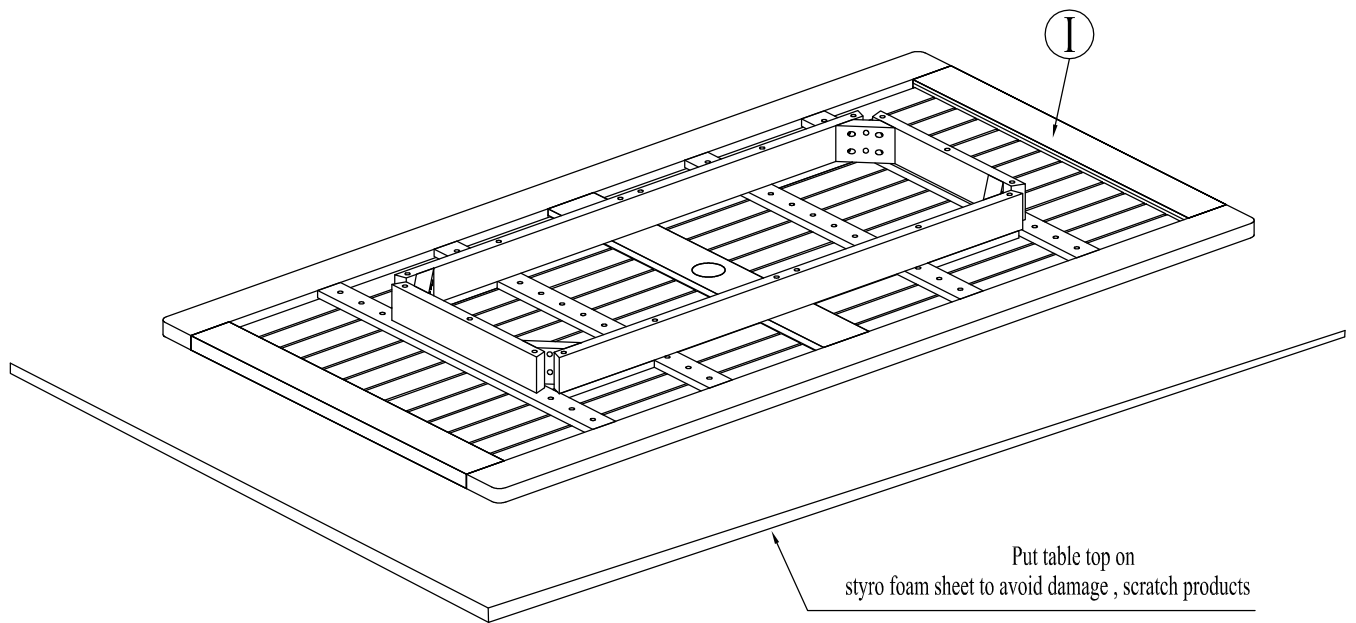

Step 2

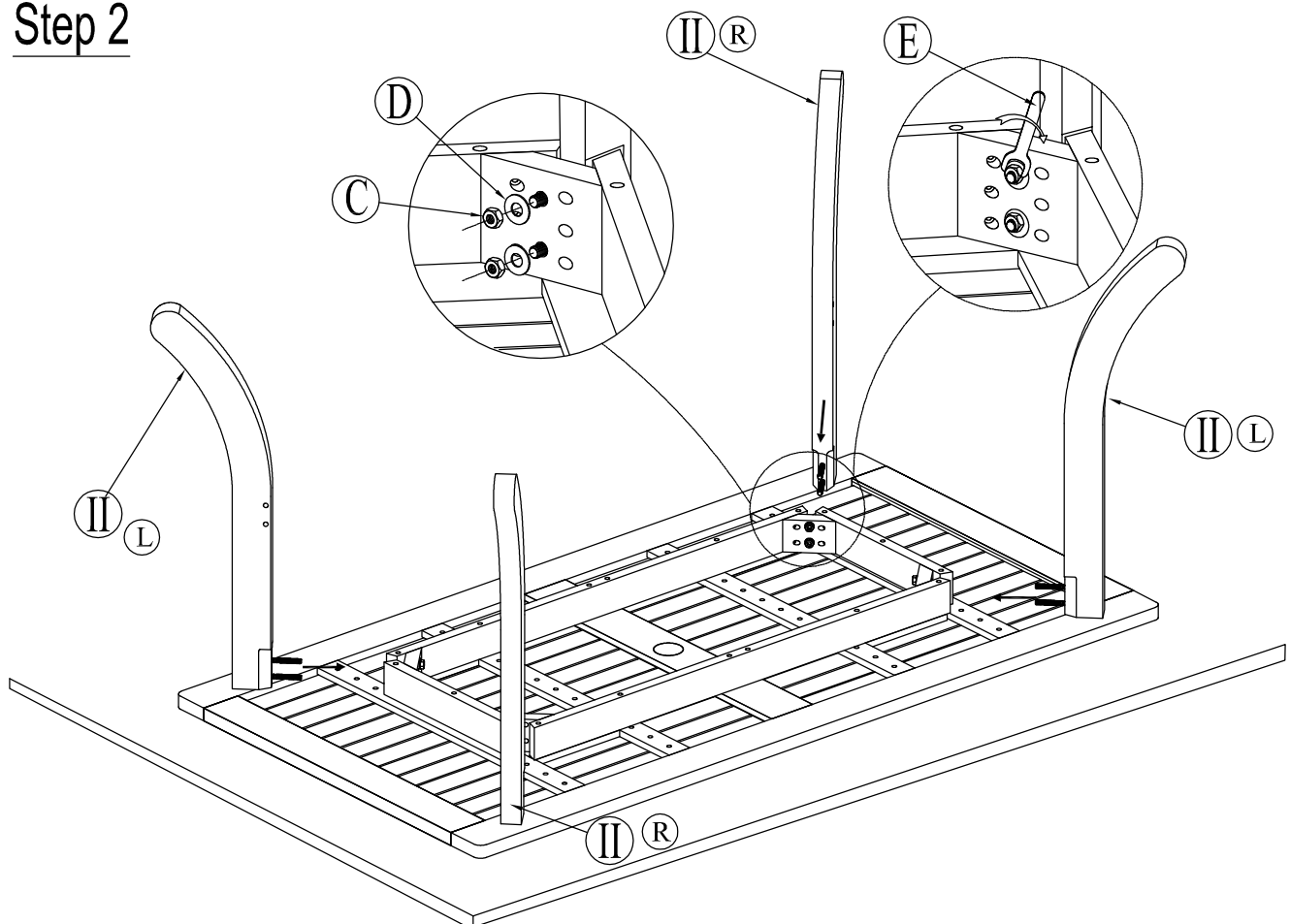

Step 3

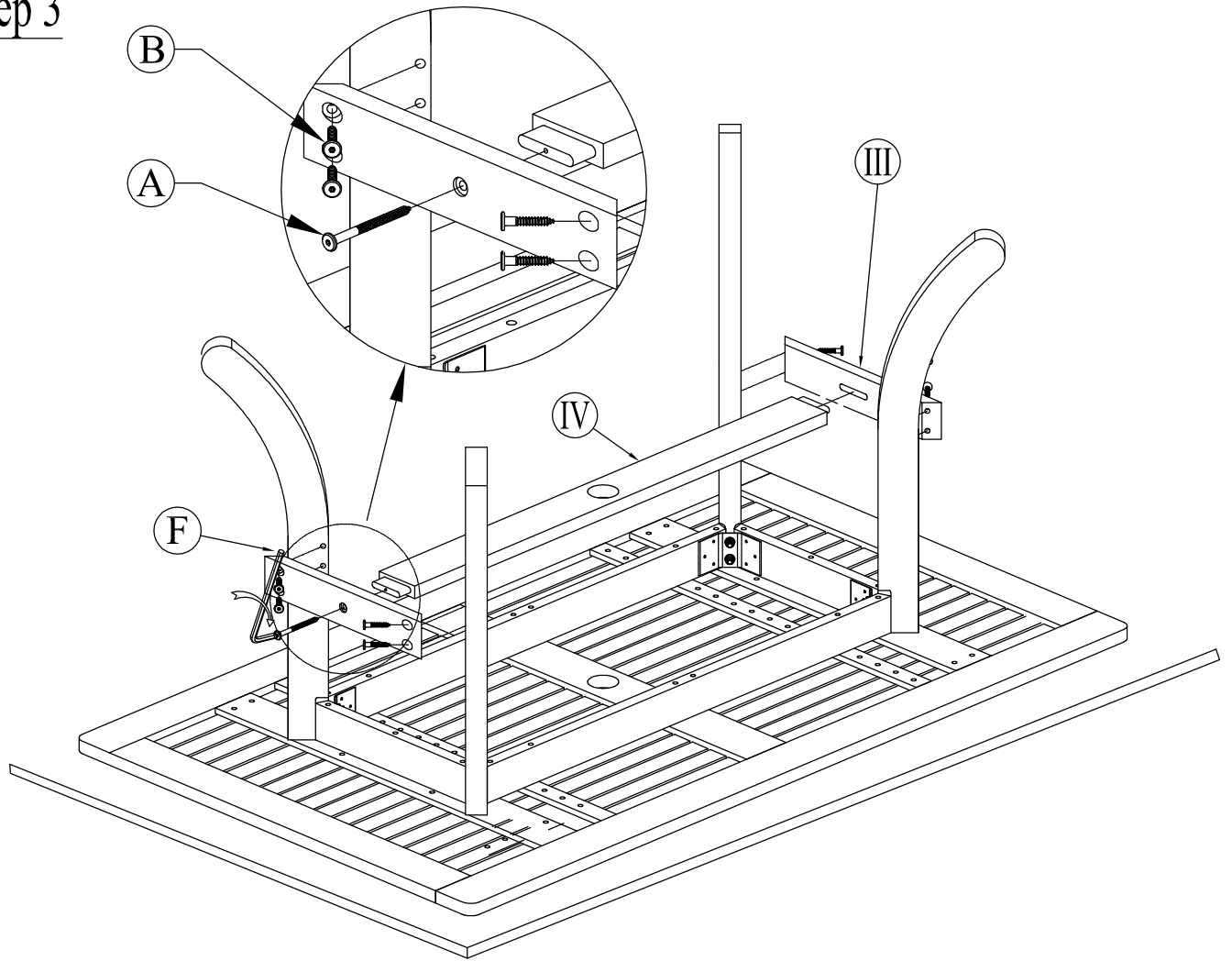

Step 4

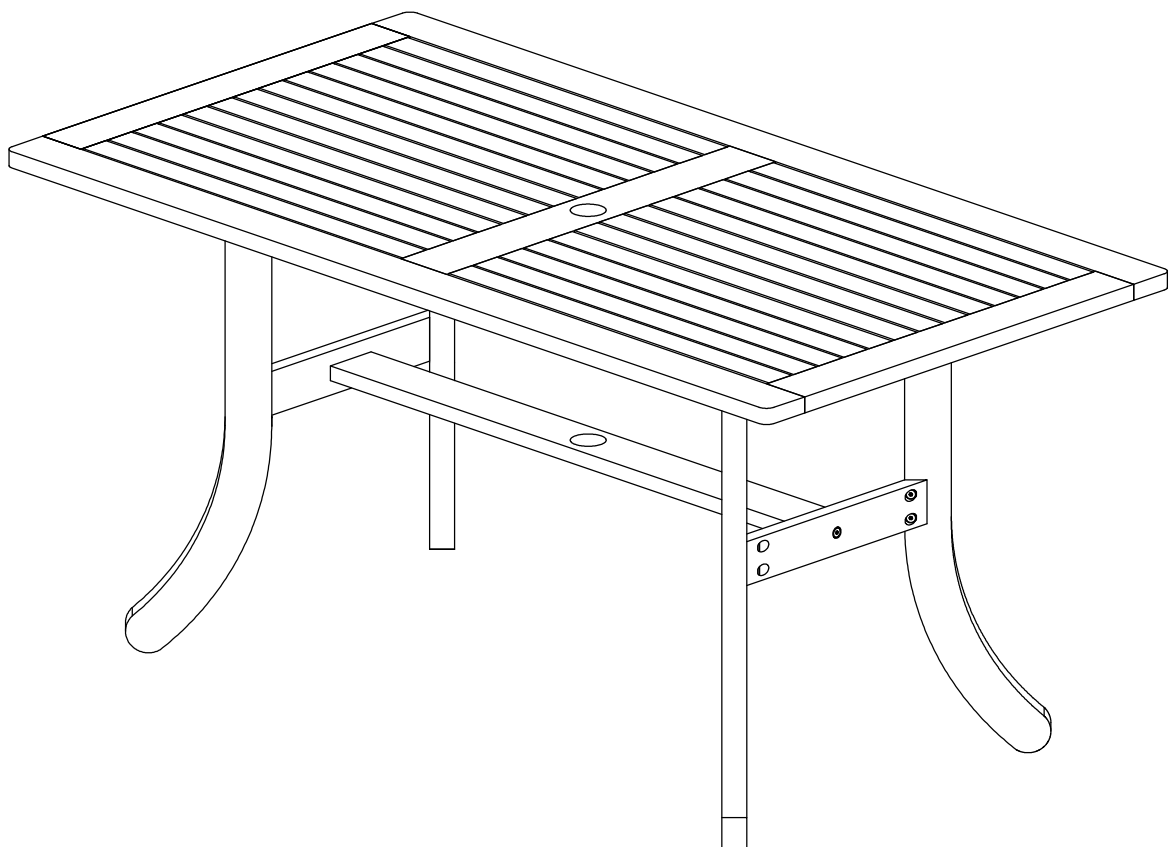

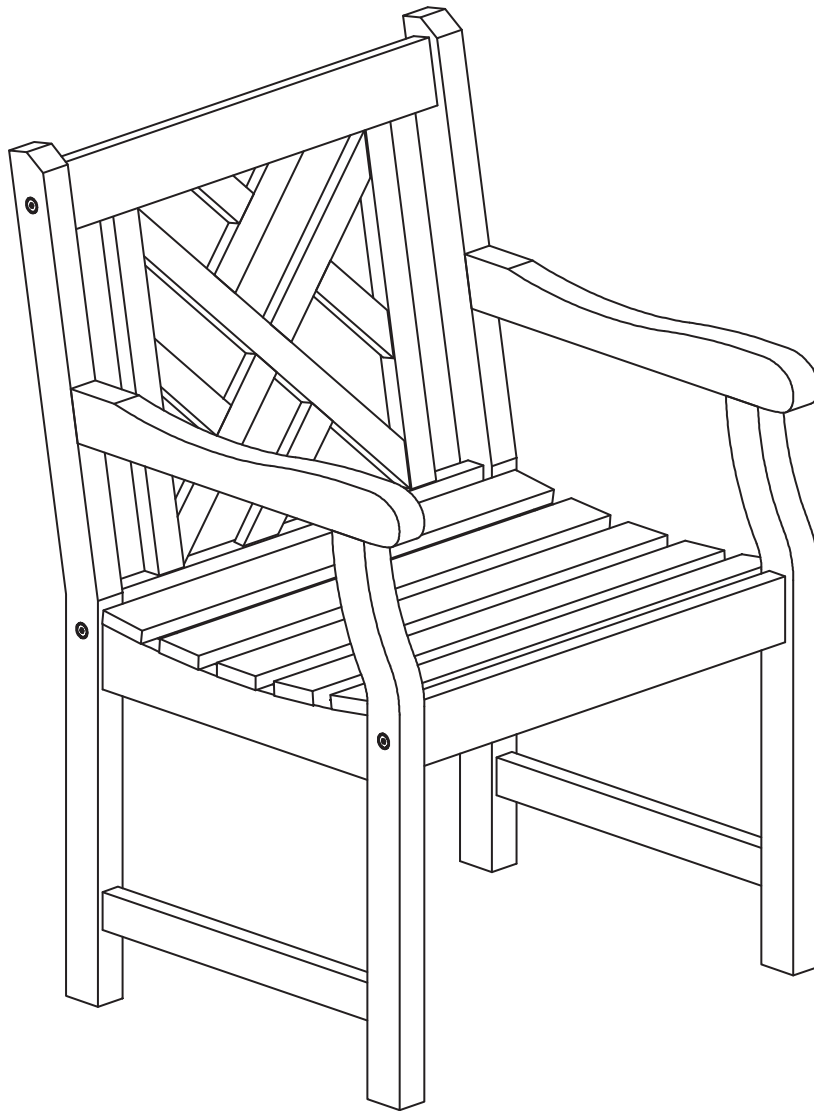

Maximum capacity : 110 kgs/242 Lbs



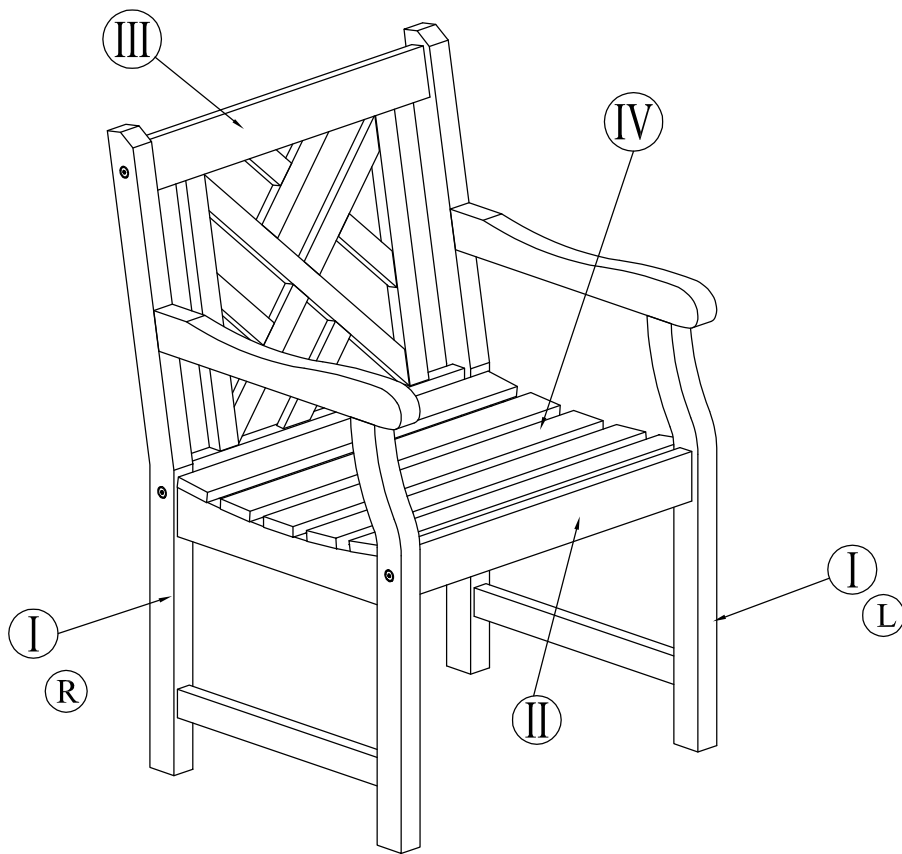

NOTE: 50% TIGHTEN BEFORE FIXING ALL BOLTS & SCREWS

COMPONENTS LIST

<p>ⓐ</p> <p>Ⓡ Ⓛ</p> <p>Q'TY 2 (Right & Left)</p>	<p>ⓑ</p> <p>QTY 1</p>	<p>ⓓ</p> <p>QTY 1</p>
<p>ⓒ</p> <p>QTY 1</p>		

HARDWARE LIST

A		6	Screw 7 x 90	C		2	Allen Key
B		2	Screw 7x40				

Step 1

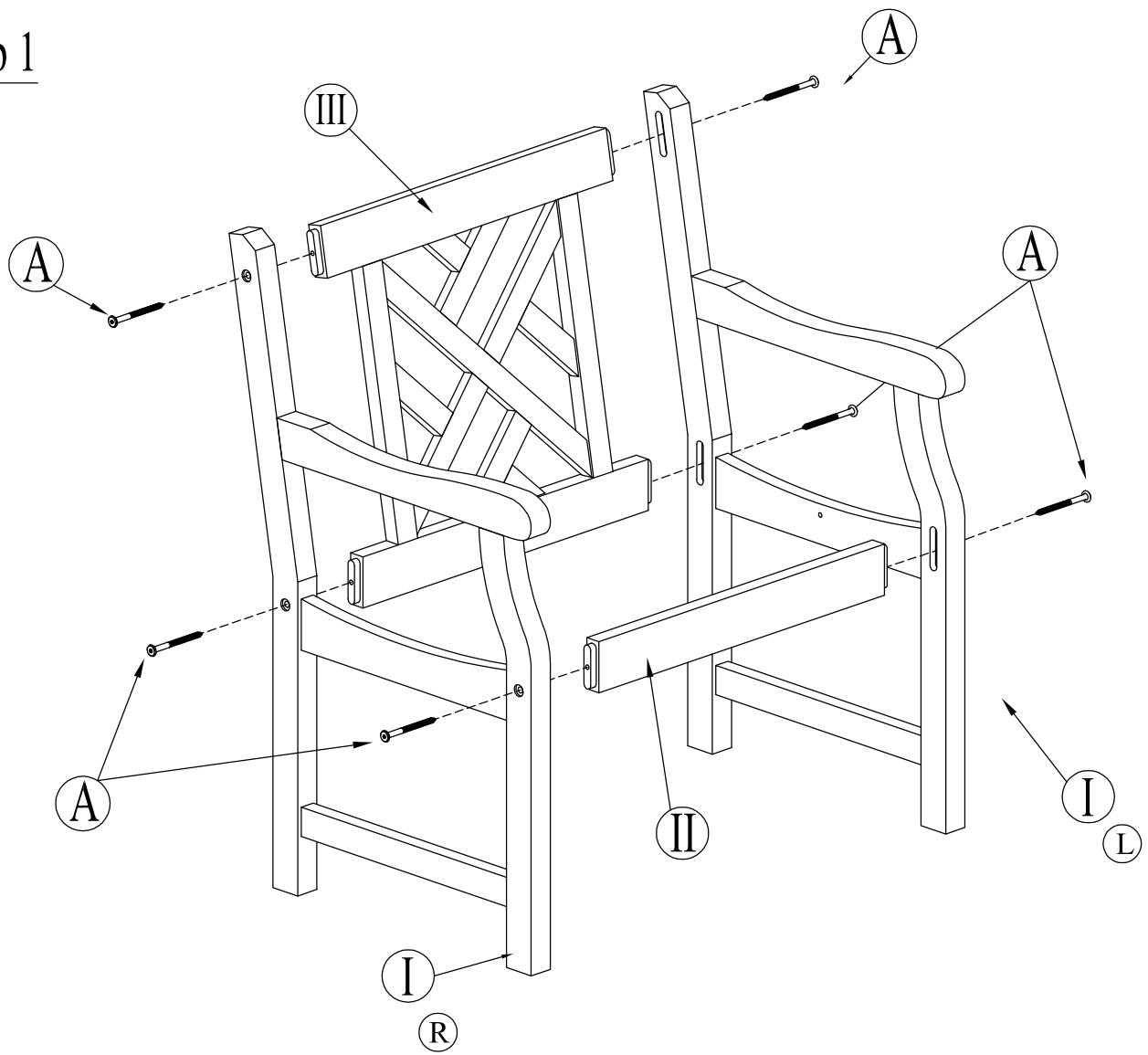

Step 2

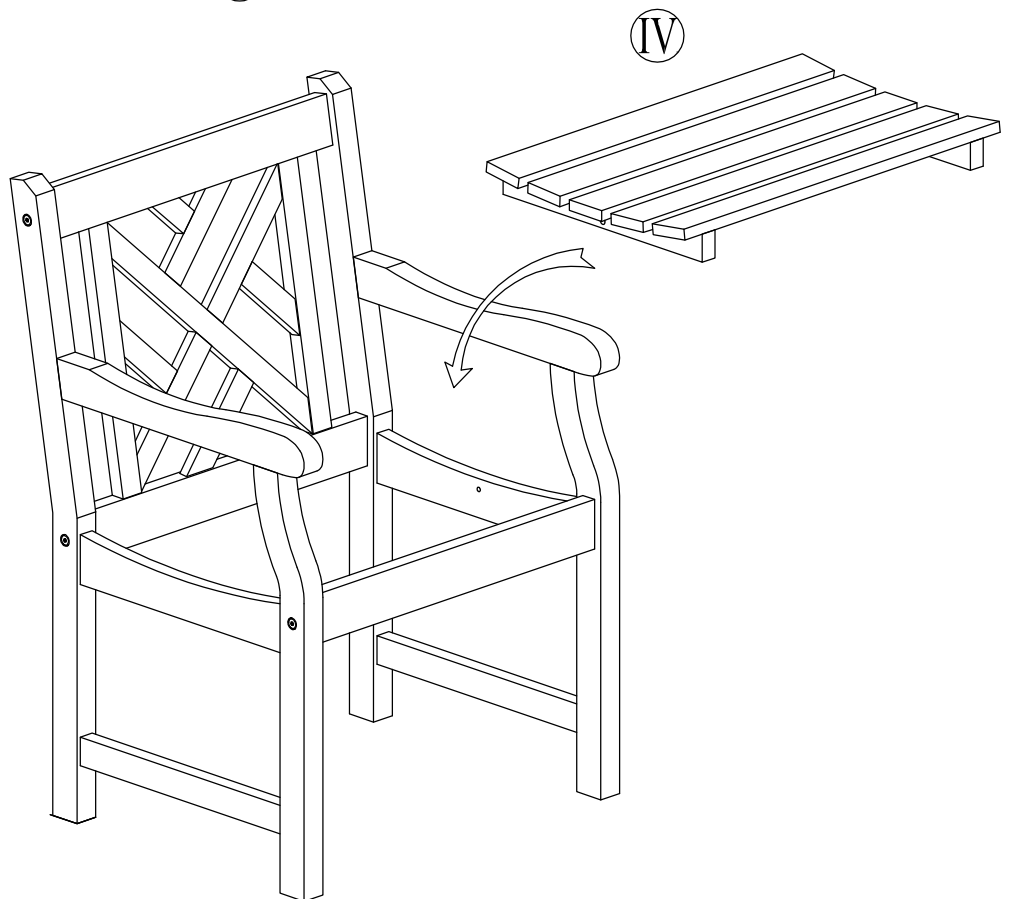

Step 3

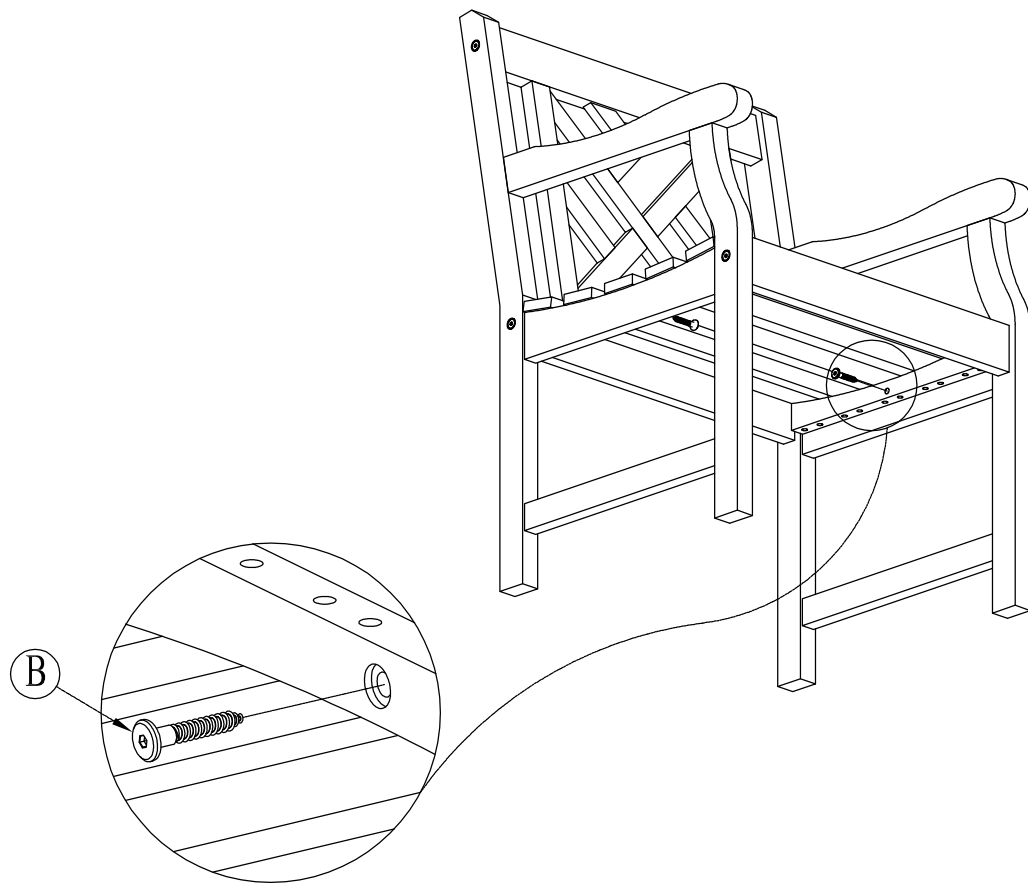

Step 4

