

ASSEMBLY INSTRUCTIONS

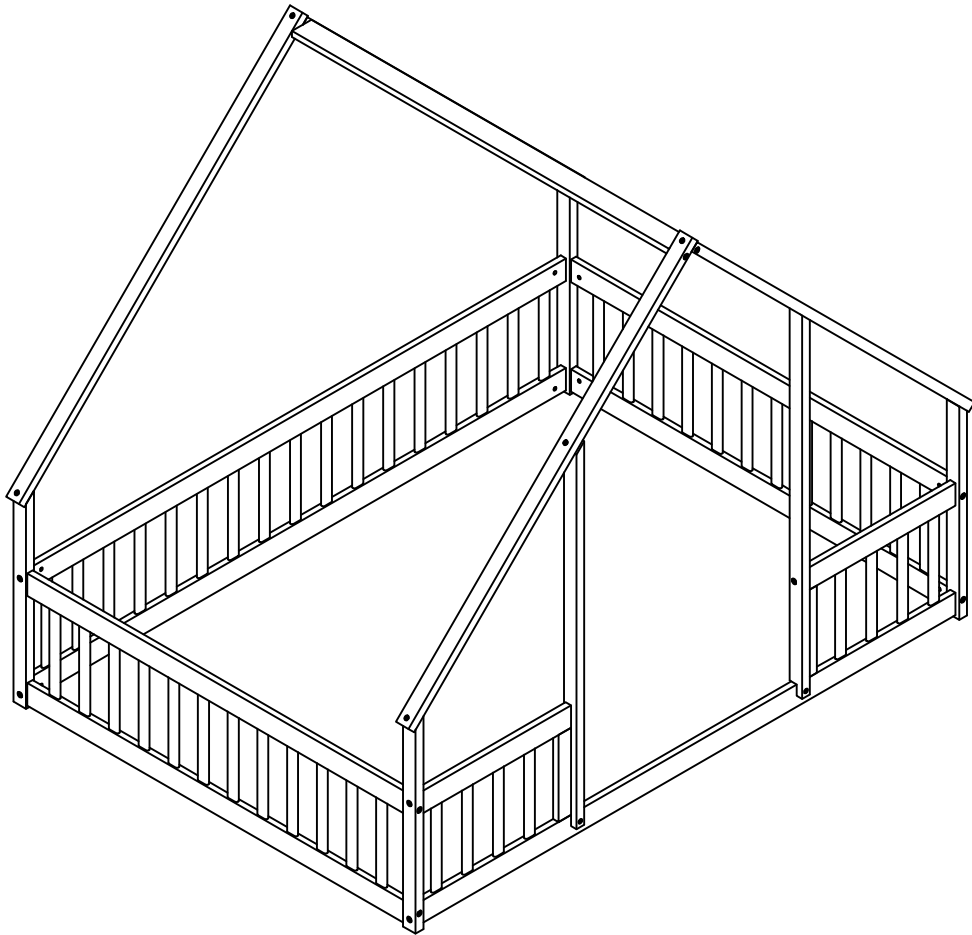

FULL HOUSE FLOOR BED

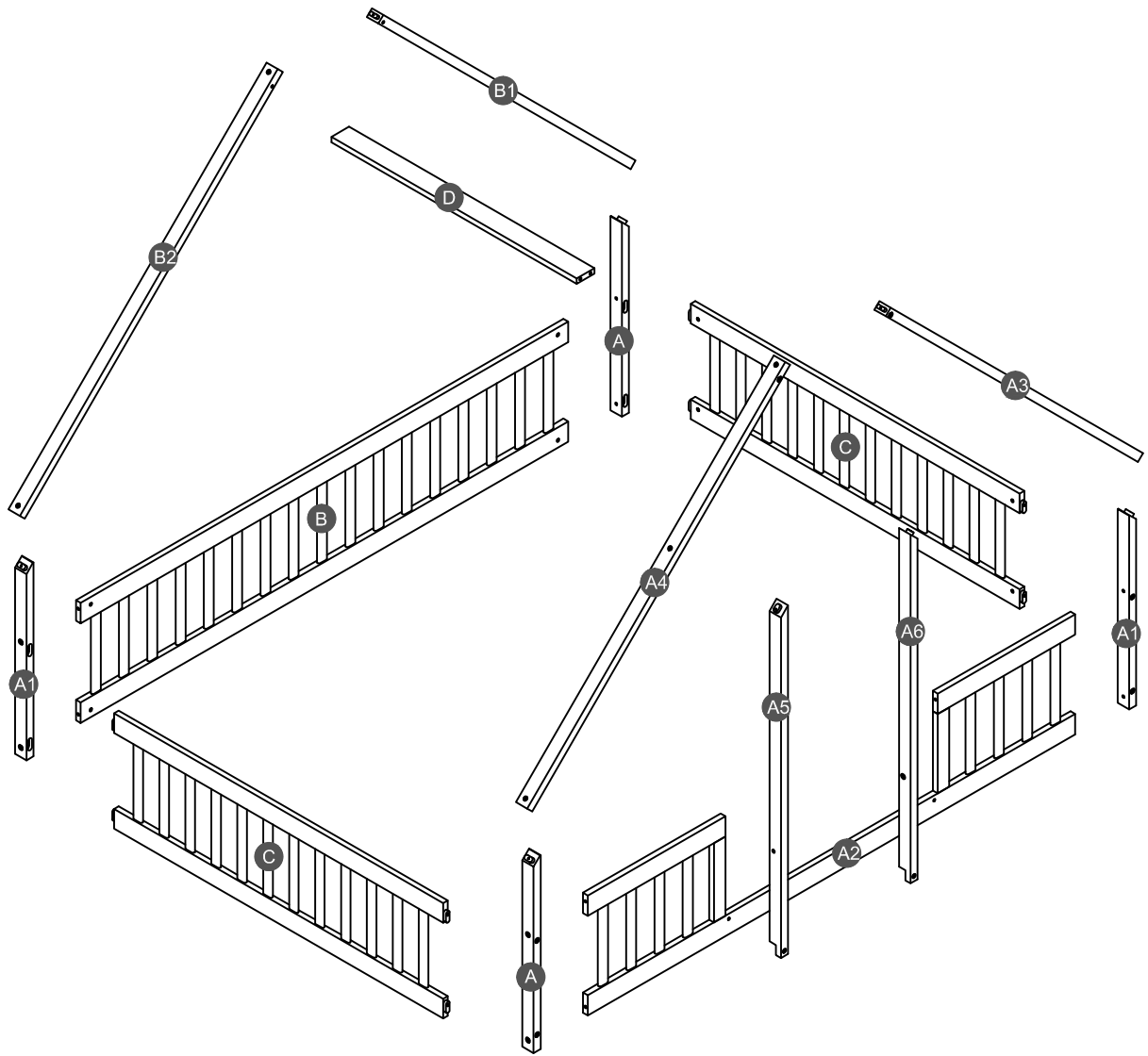



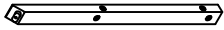
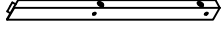

Detail View

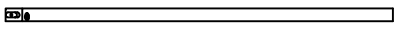
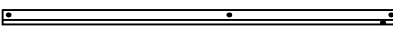
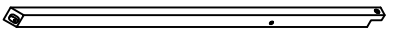
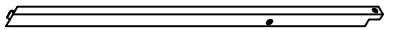
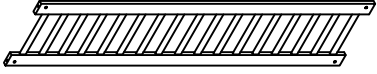
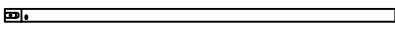
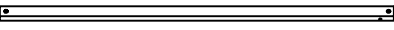
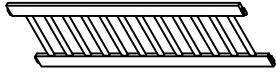
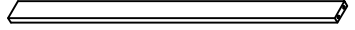

Part List

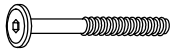
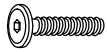
| | | |
|--|--|---|
| A  Leg (Left Front/Right Back) - 2pcs | A1  Leg (Left Back/Right Front) - 2pcs | A2  Guard rail (Front) - 1pc |
| A3  Horizontal bar (Right Front) - 1pc | A4  Horizontal bar (Left Front) - 1pc | A5  Vertical bar (Left Front) - 1pc |
| A6  Vertical bar (Right Front) - 1pc | B  Guard rail (Back) - 1pc | B1  Horizontal bar (Right Back) - 1pc |
| B2  Horizontal bar (Left Back) - 1pc | C  Guard rail HB/FB - 2pcs | D  Upper horizontal bar - 1pc |

Hardware List

| | | |
|---|--|--|
| 1  (Ø15)1/4"*80mm Hex-Head bolts (22pcs) | 2  (Ø12)1/4"*35mm Hex-Head bolts (2pcs) | 3  1/4"*15 (9.5mm) Horizontal-Hole bolts(22pcs) |
| 4  (Ø12)1/4"*40mm Hex-Head bolts (8pcs) | 5  (1/4")4.5*58mm Allen key (1pc) | |

ASSEMBLY TOOLS REQUIRED (NOT INCLUDED)

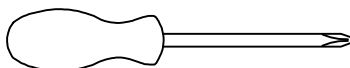

PLEASE BE CAREFUL DO NOT DAMAGE THE HOLE POSITION WHEN YOU USE POWER TOOLS !

STEP 1:

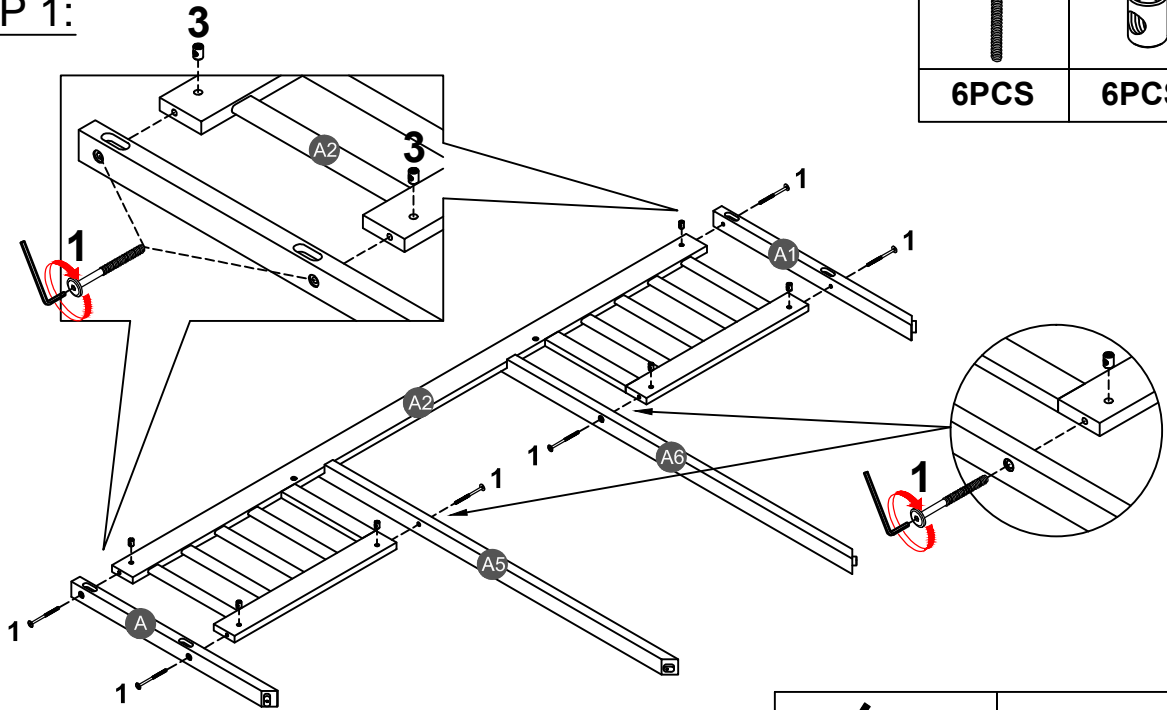

| | | | |
|-------------|--|-------------|--|
| 1 | | 3 | |
| 6PCS | | 6PCS | |

Note: Part 3 will face up with the "x" mark on it, otherwise it cannot be tightened

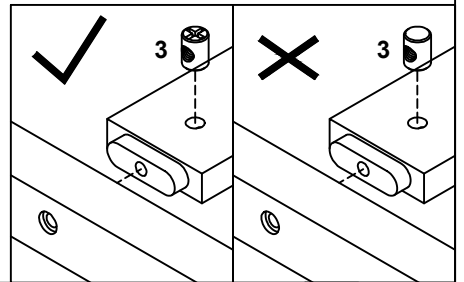

STEP 2:

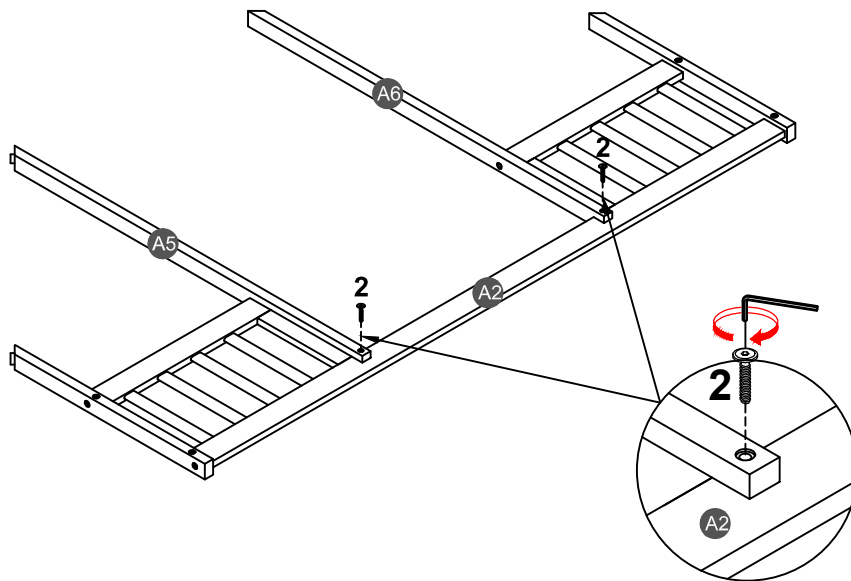

| | |
|-------------|--|
| 2 | |
| 2PCS | |

STEP 3:

4



5PCS

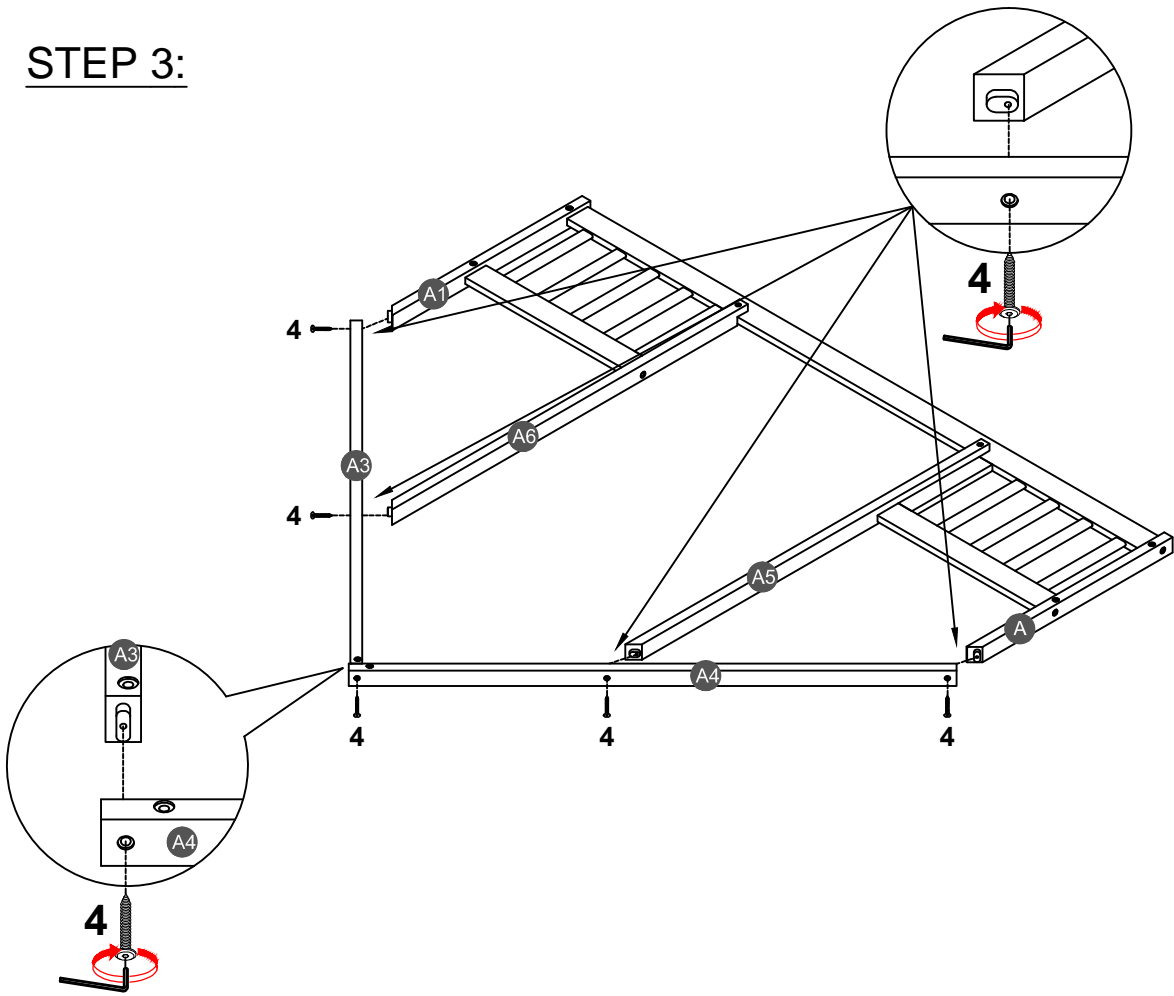

STEP 4:

1



4PCS

3



4PCS

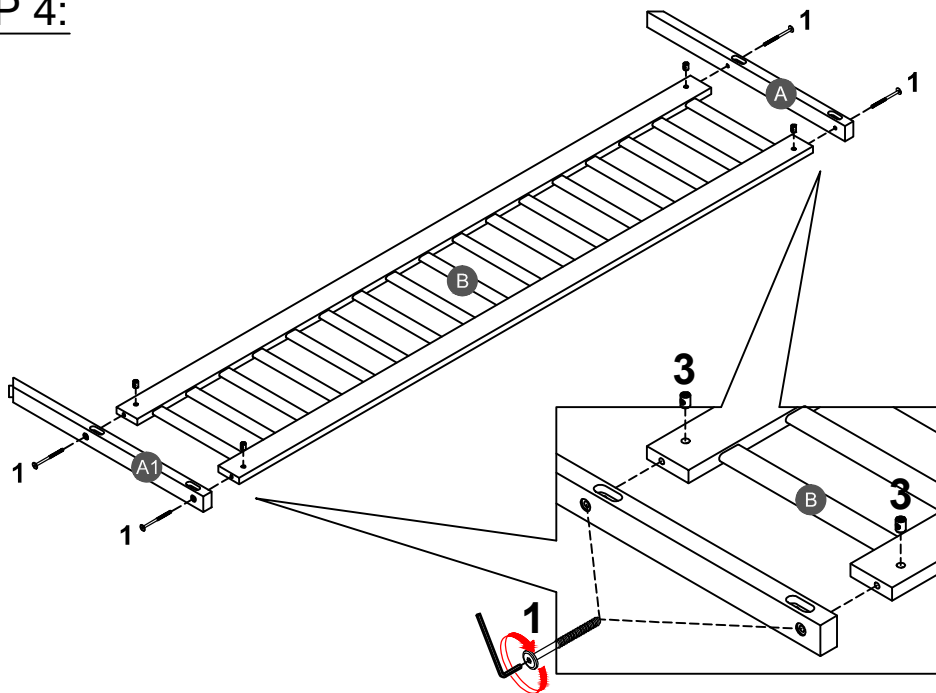

STEP 5:

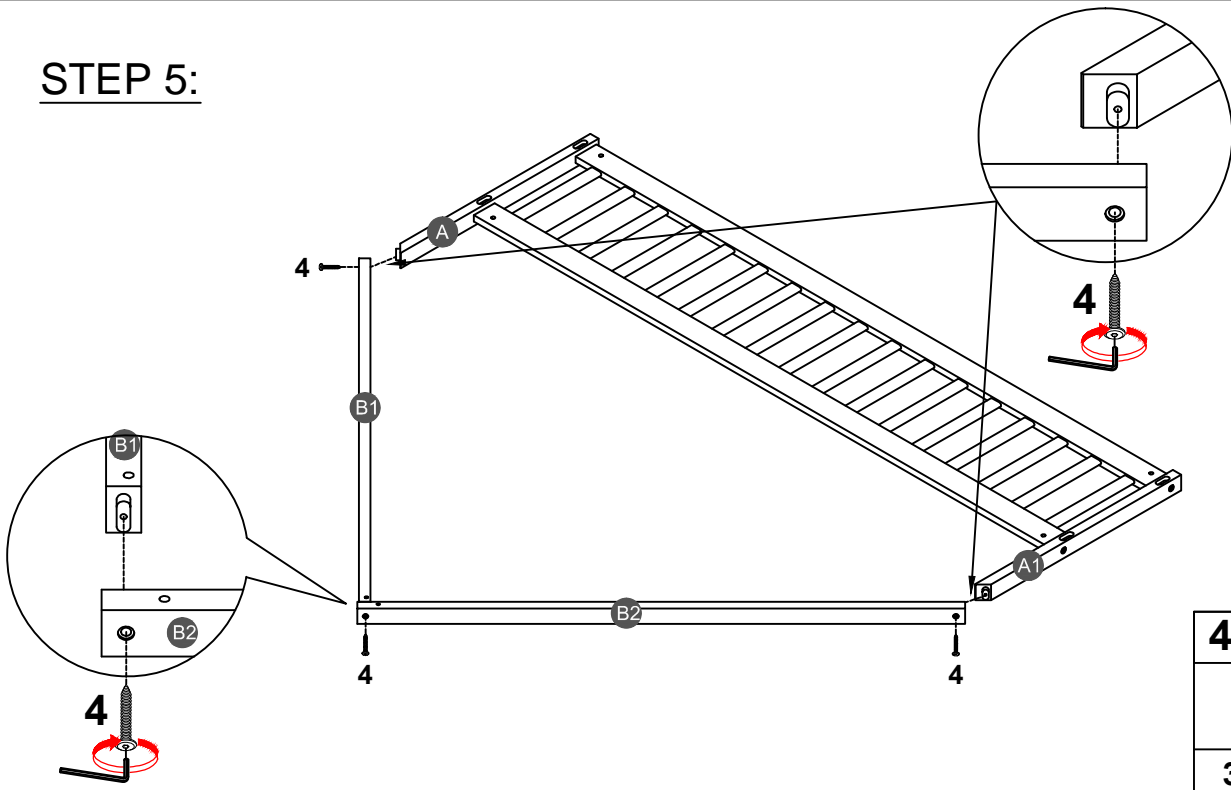

STEP 6:

