

WARNING: Risk of Shatter Associated with Glass Furniture

Please note that in rare instances, glass furniture that is damaged by chips or scratches may break, seemingly of its own accord. Damage to the glass (not always visible) can get worse over time until it reaches a critical point when it may shatter. In the event of damage, this product is designed to shatter into lots of small granular pieces rather than large shards. This is a safety feature to reduce the risk of injury.

To reduce the risk of damage, we recommend the following:

- During assembly do not lay the glass directly onto hard or rough surfaces. Lay the glass on a blanket or cardboard.
- When lifting or moving the product, ask for someone to lend a hand. Trying to move a product on your own can lead to accidents.
- Do not use the furniture if any parts are missing or broken.
- Do not place very hot or very cold items directly on the glass surface; we recommend using a trivet. Extreme temperature differences over small areas can cause damage, which could in turn lead to shattering.
- Do not sit or stand on the glass surface.
- Do not strike the glass with hard or pointed items, or use the glass as a chopping surface.
- Do not drag rough or heavy objects over the top of the glass.

Assembly Instructions

Caution : You must read this before you proceed



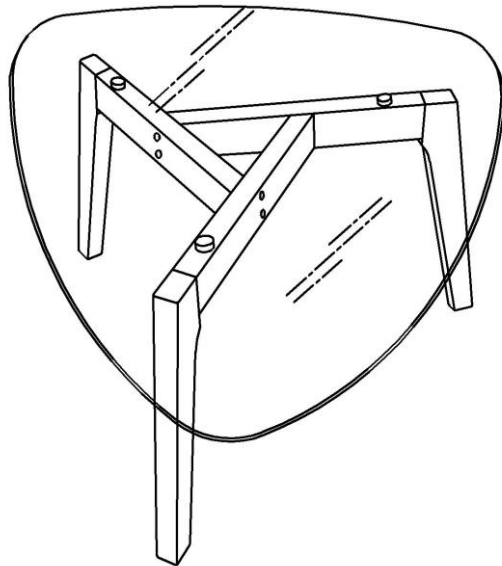

GLASS COFFEE TABLE





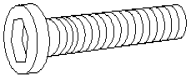

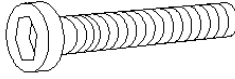

Parts List

| Label | Picture | Description | QTY |
|-------|---------|-------------|-----|
| A | | Table Top | 1 |
| B | | Table Leg | 3 |

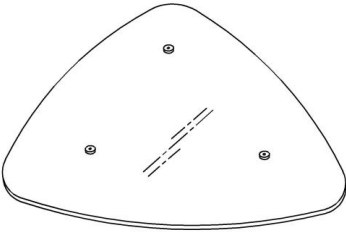
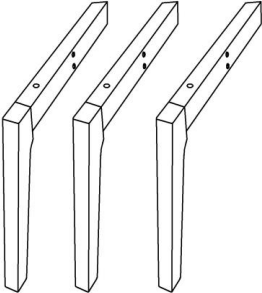
Hardware

| Label | Picture | Description | QTY |
|-------|---|---------------------------------------|-----|
| ① |  | Allen Key (4mm) | 1 |
| ② |  | Bolt (Φ 1/4"x2") | 7 |
| ③ |  | Spring Washer (Φ 1/4") | 11 |
| ④ |  | Flat washer (Φ 1/4"xΦ 12x1.5mm) | 11 |
| ⑤ |  | Bolt (Φ1/4"x2-1/2") | 4 |
| ⑥ |  | Wooden cover (Φ 14mm) | 6 |

Assembly Preparation

| | | |
|-----------------------------------|--|---|
| <p>Before Beginning Assembly:</p> |   |  X 1 PC  X 7 PCS  X 11 PCS  X 11 PCS  X 4 PCS  X 6 PCS |
|-----------------------------------|--|---|



- Read instructions, cover to cover-



- Have 2 adults on hand for assembly-



- Do not assemble on flooring or carpet-



- Assemble on a clean non-marring surface (packing foam)-



- Save all packaging until finished-

Assembly Steps

Overview

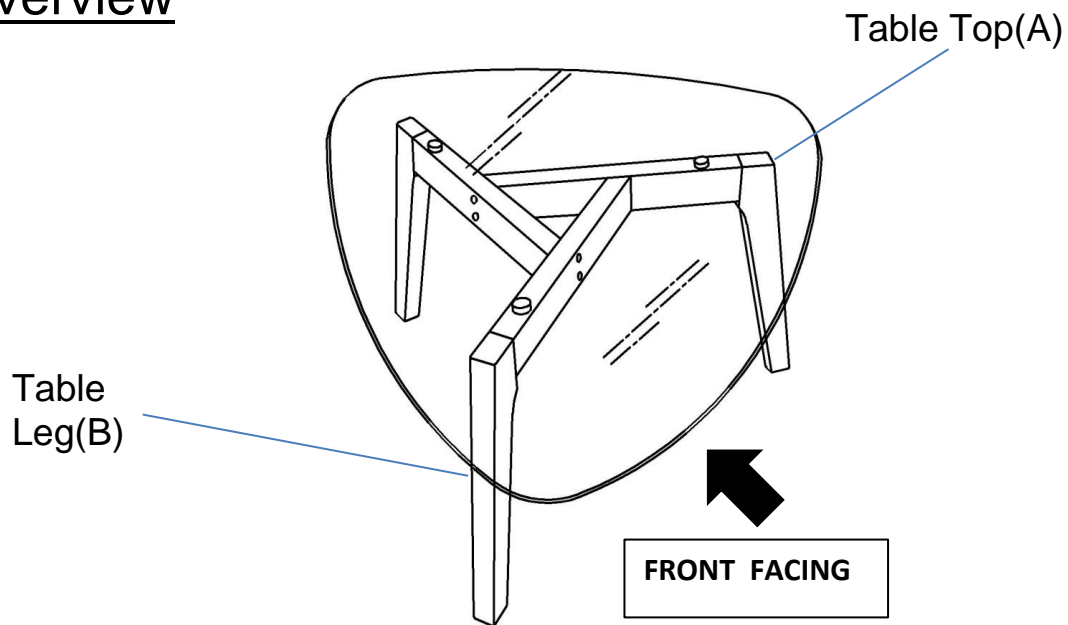

This table has multiple parts and may require up to some 30 minutes to assemble. To give you an overview of the table parts, the above picture is to help you put the various parts into perspective. Please read through the instructions below to familiarise yourself with the parts and steps before assembly.

Step 1

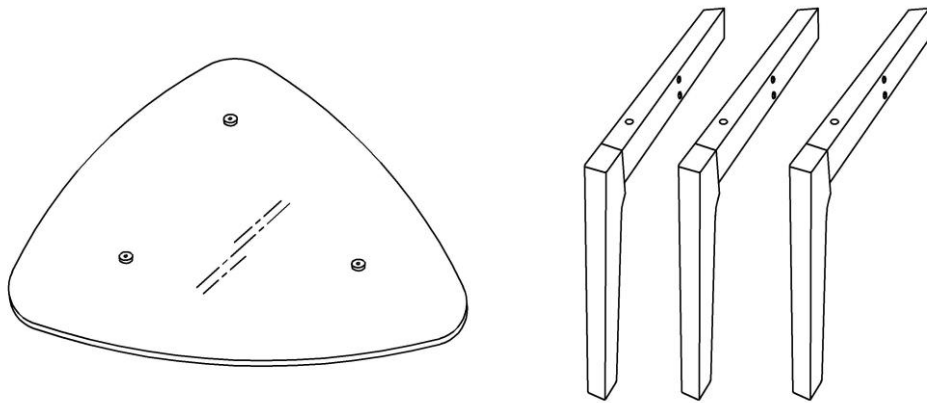

Unpack and place all parts on a clean, non-marring surface.

Step 2

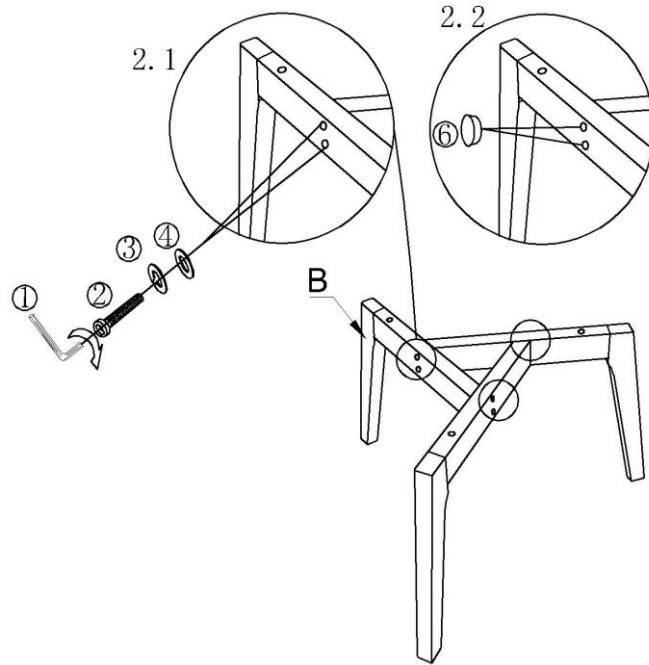

Tighten the Table leg (B) with Bolts ((2)), Spring washers ((3)), Flat washers ((4)), and the Allen key ((1)), as shown in Figure (2.1), then cover with the Wooden cover ((6)), as shown in Figure (2.2).

Step 3

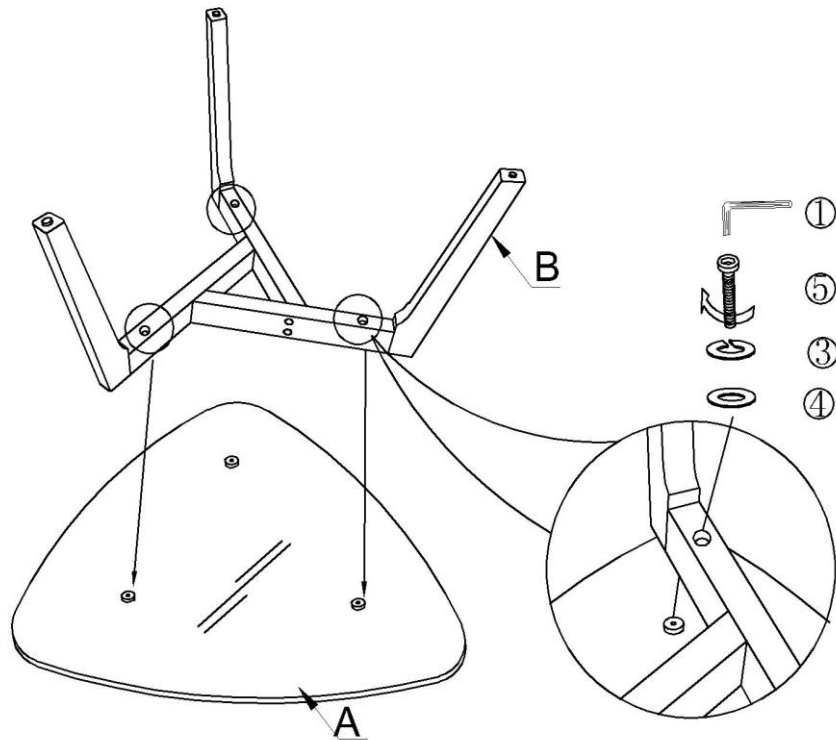

Place the Table top (A) face down and legs up.
Place on a clean soft surface to avoid scratches or damage to the product.
The Table top (A) and Table leg (B) are affixed using the Allen key (①) Bolts (⑤), Spring washers (③), and Flat washers (④) as shown.

Step 4

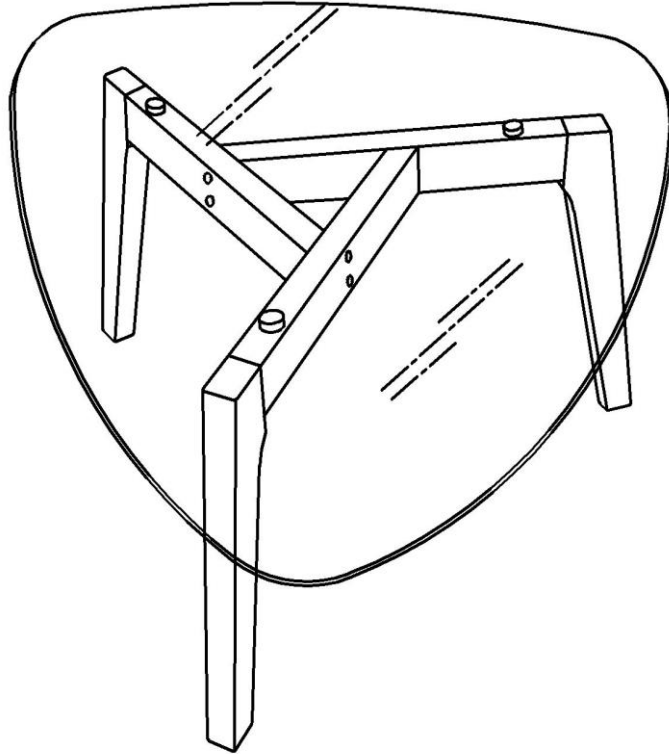

CAUTION 1: When tightening these bolts, tighten sequentially.
If there are any wobbles after tightening, loosen the bolts and execute this same process.

Ensure all bolts are fully locked into position.

Caution 2: This can only be used on a flat, level surface.

Your Table is ready for use.

This Table can only be used on a flat, level surface.

Care & Maintenance



- Furniture may scratch floors. We recommend using furniture pads to protect your floors.



- Do not put hot items directly on furniture surface.



- Do not clean furniture with harsh cleansers or polish.



- Do not place furniture under direct sunlight.



- Do not place furniture near heating or cooling vents.



- Do not write on furniture without a padded barrier to protect the surface.



- Do not place furniture outside . For indoor use only.



- Not for commercial use. For residential use only.



- Stains may be removed with mild soap solution and damp cloth.



- Children should not climb or jump on the furniture.



- Dust and pick-up spills using a clean, non-colored, lint-free cloth.