

End Table

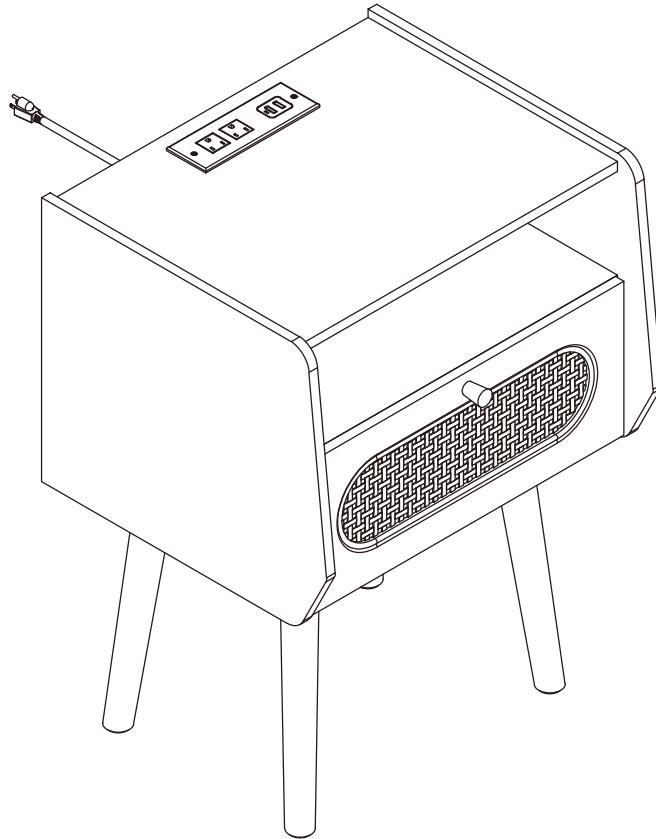

Please make sure to read the instruction manual carefully before installing the product.

Do Not Return This Product!

Contact our customer service team
for help first.



WARNING

- Unit can tip over causing severe injury or death.
- Anchor unit to stud in wall (if instructed to)
- Do Not allow children to climb on unit.
- put heavy items on lower shelves or drawers.

**PEOPLE NEEDED
FOR ASSEMBLY: 1**

HELPFUL HINTS

PEOPLE NEEDED FOR ASSEMBLY: 1
ESTIMATED ASSEMBLY TIME: 1 HOUR

- Open your item in the area you plan to keep it to avoid excessive heavy lifting.
- Identify, sort and count the parts before attempting assembly.
- Back panel must be used to make sure your unit is sturdy.
- Do NOT use harsh chemicals or abrasive cleaners on this item.
- Never push,pull,or drag your furniture.





BEFORE YOU START

- Read through each step carefully and follow the proper order
- Separate and count all your parts and hardware
- Give yourself enough room for the assembly process
- Have the following tools:Flat Head Screwdriver,#2 Phillips Head Screwdriver and Hammer
- Caution: IF using a power drill or power screwdriver for screwing,please be aware to slow down and stop when screw is tight.Failure to do so may result in stripping the screw.

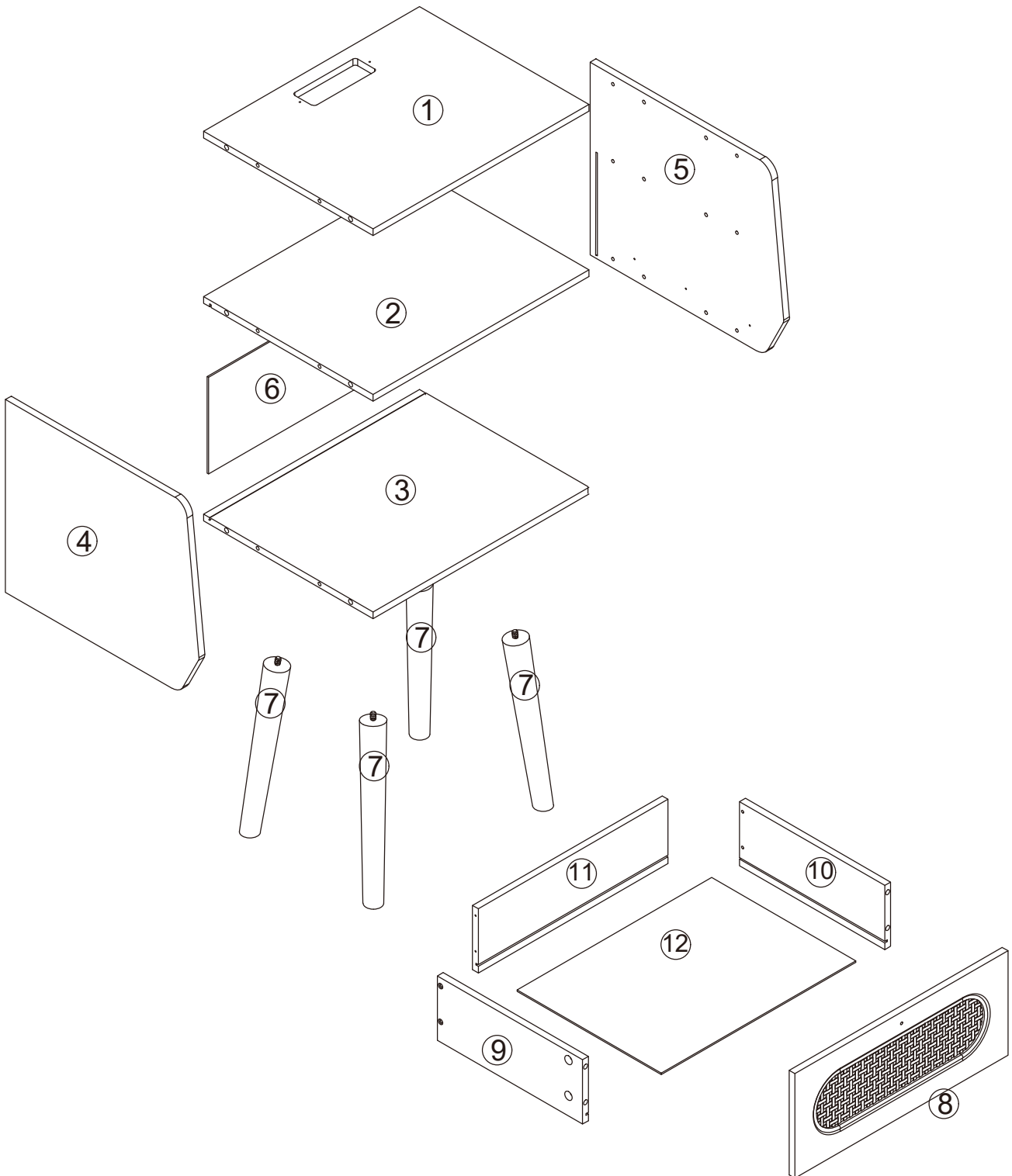



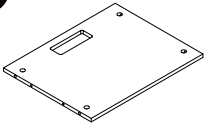
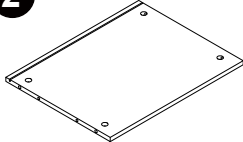
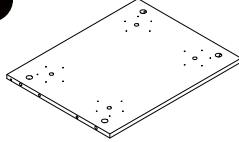
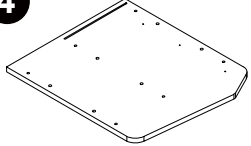
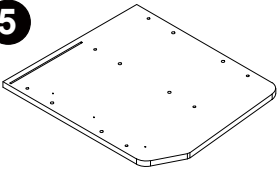
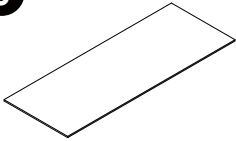

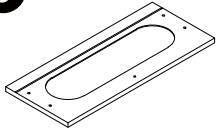
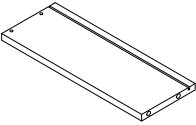
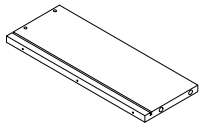
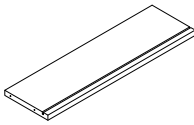
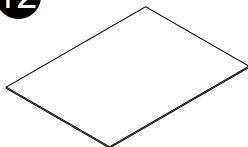



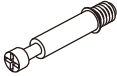



BOARD IDENTIFICATION



BOARD IDENTIFICATION

1  1PC	2  1PC	3  1PC	4  1PC
5  1PC	6  1PC	7  4PCS	8  1PC
9  1PC	10  1PC	11  1PC	12  1PC

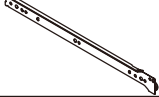
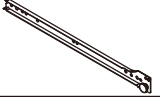
THE HARDWARES

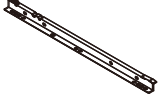
A Ø6x35mm  Cam Bolt 16PCS	B Ø15x10mm  Cam Lock 16PCS	C Ø6x30mm  Wood Dowel 12PCS	D Ø4x35mm  Screw 4PCS	E Ø3x12mm  Screw 12PCS
F Ø3x14mm  Backplane Buckle 4PCS	G  Angle Bracket 4PCS	H Ø4x12mm  Screw 20PCS	I  Handle and Screw 1PCS	J  Row insertion 1PCS
K  Screw 2PCS	L  Hole sticker 8PCS	M  Foot pad 4PCS	CL 250mm  Slide rail 1PCS	CR 250mm  Slide rail 1PCS
DL 250mm  Slide rail 1PCS	DR 250mm  Slide rail 1PCS			

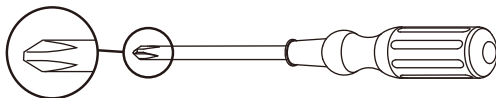

Phillips Screwdriver Power Tool NOT Recommended

IMPORTANT :

1. Do not tighten bolts / screws completely until all bolts / screws are lined up and inserted into holes.
2. Do not over tighten screws and bolts to avoid stripping.
3. Please use hand tools to assemble this product. Do not use power tools.
4. Must need 1 people to assemble this product.



CAM LOCK FASTENING SYSTEM

This Cam Lock Fastening System will be used throughout the assembly process.

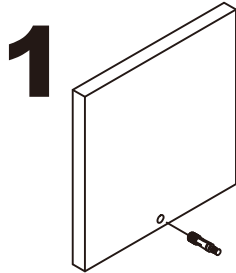

1 Press CAM BOLT into hole.

2

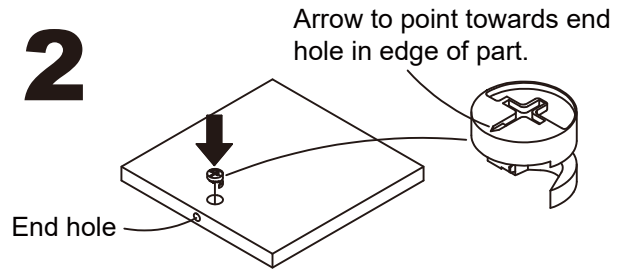

Press CAM LOCK into hole.

3

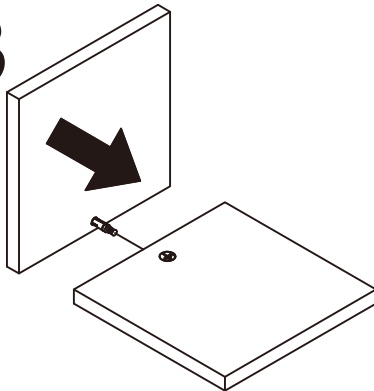

Press parts together so CAM BOLT inserts into edge hole.

4

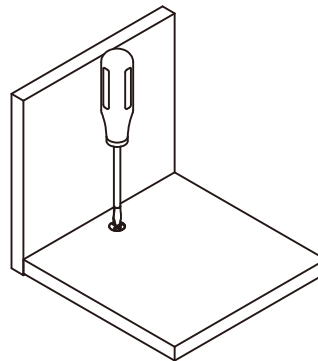

Using a screwdriver, turn the CAM LOCK clockwise to lock the CAM LOCK and CAM BOLT into their holes and fastening parts together.

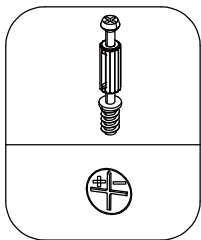

Notice: Proper orientation of CAM LOCK

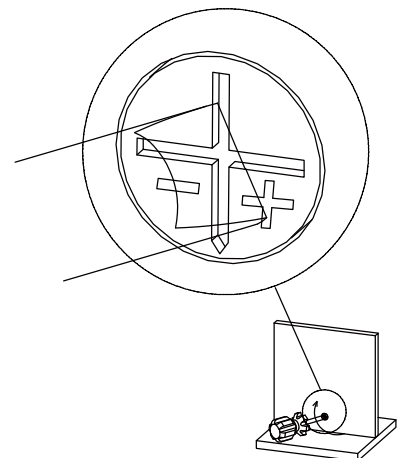
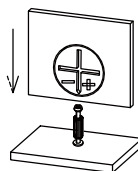
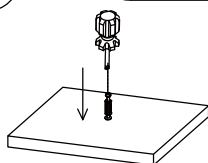
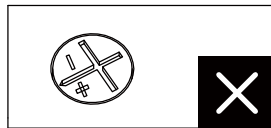
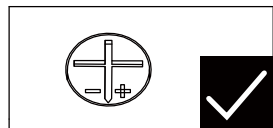

INSTALLATION STEPS

STEP 1

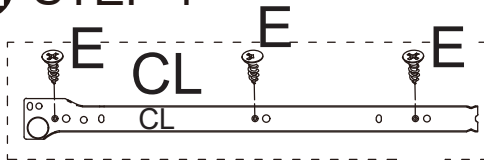

IMPORTANT : DO NOT INSTALL THE SCREWS INTO THE WRONG HOLES.

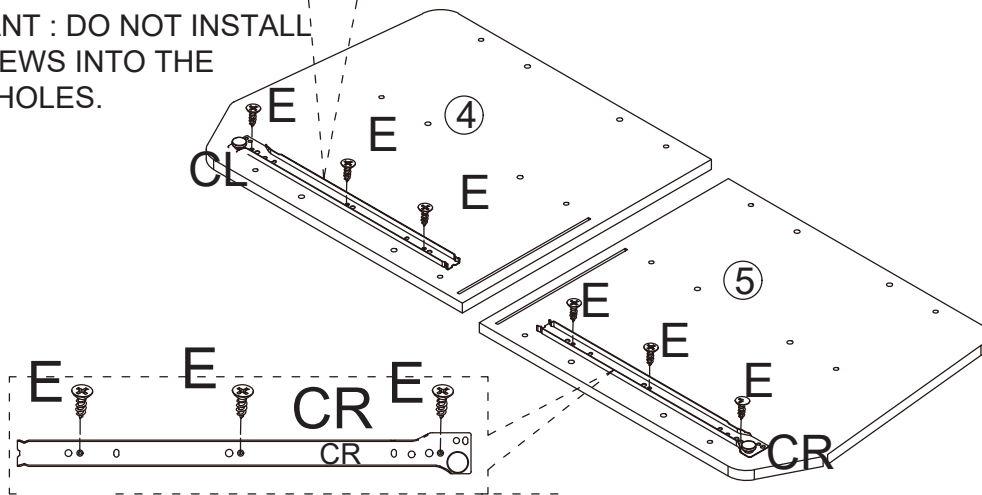

IMPORTANT : DO NOT INSTALL THE SCREWS INTO THE WRONG HOLES.

STEP 2

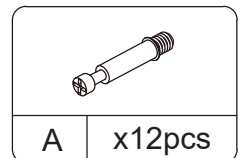
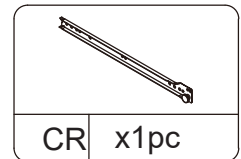
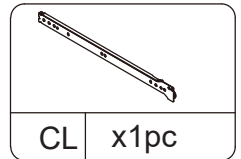
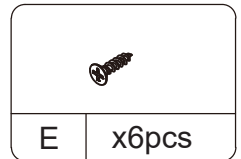
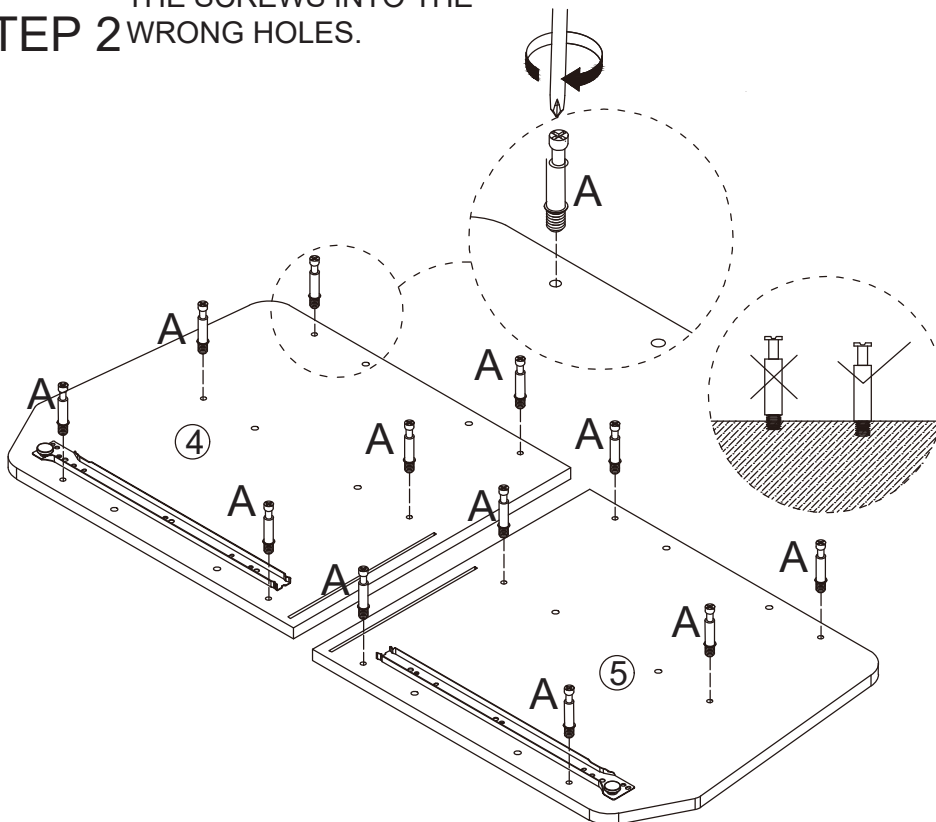

INSTALLATION STEPS

STEP 3

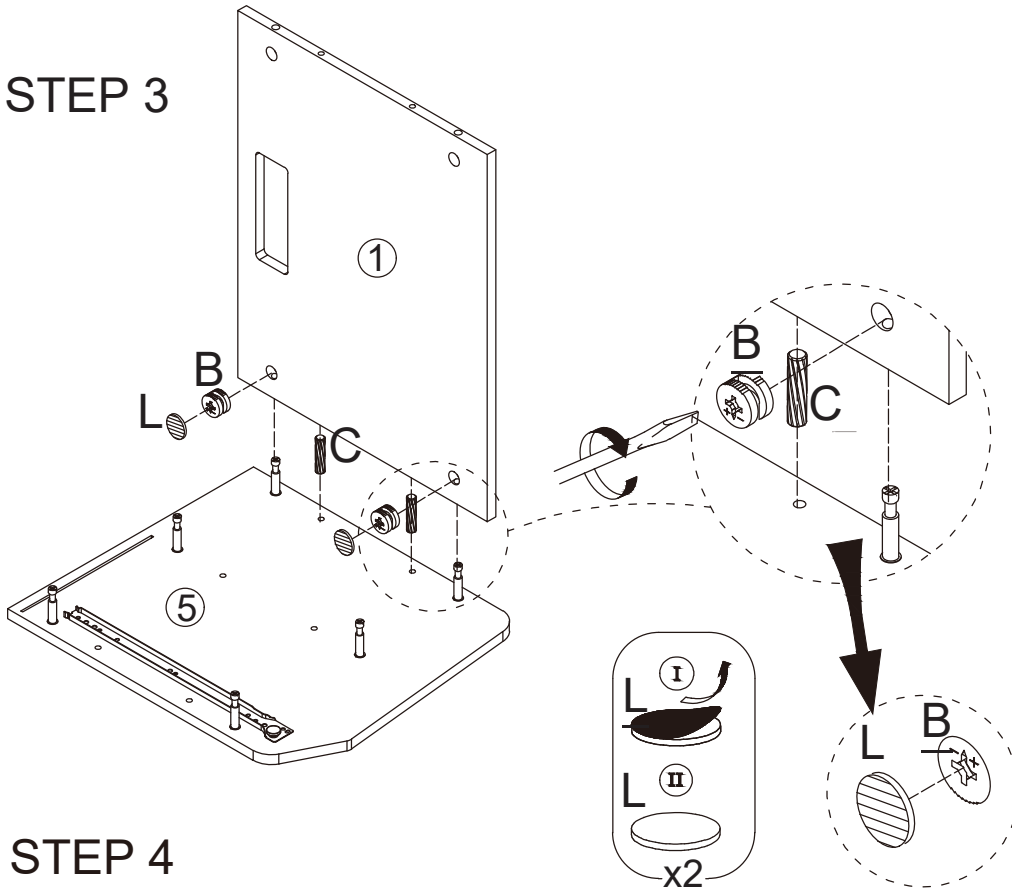

	B	x2pcs
	C	x2pcs
	L	x2pcs

STEP 4

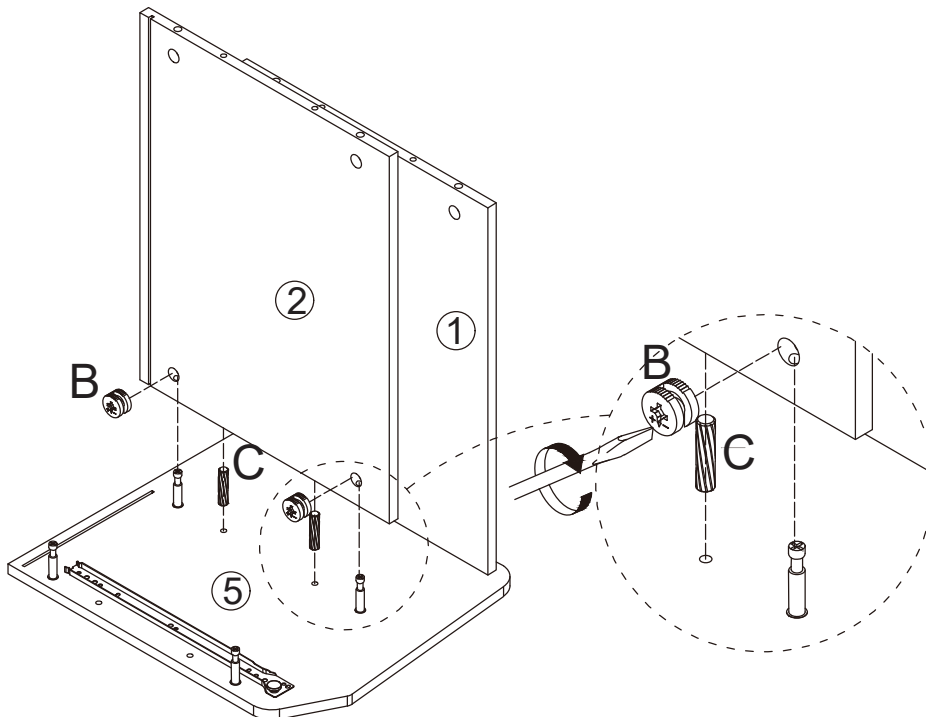

	B	x2pcs
	C	x2pcs

INSTALLATION STEPS

STEP 5

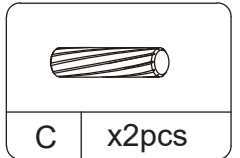
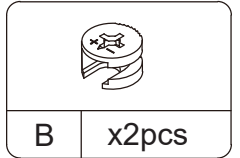
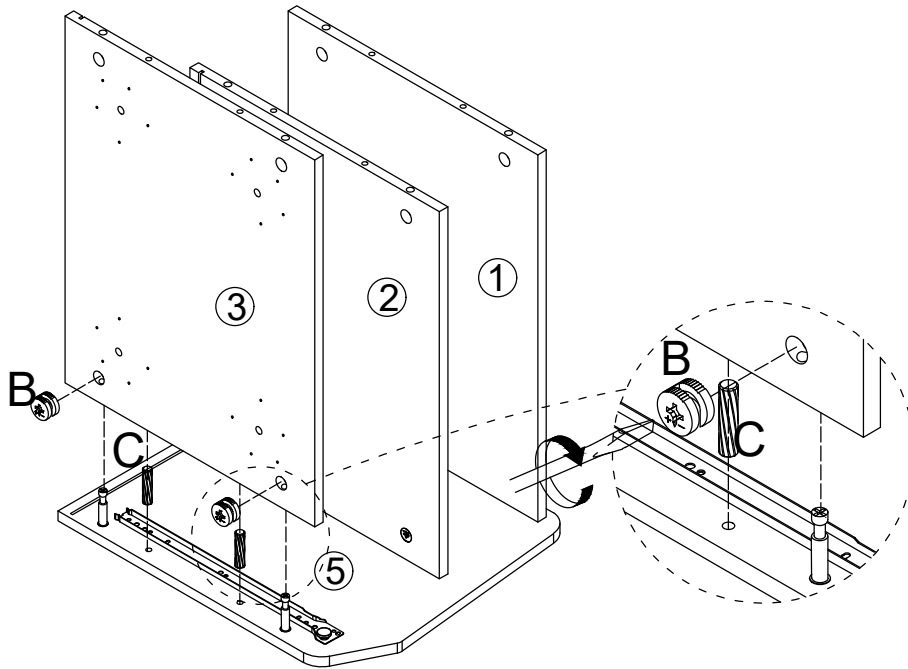

STEP 6

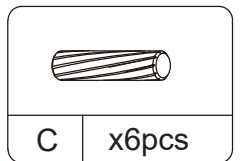
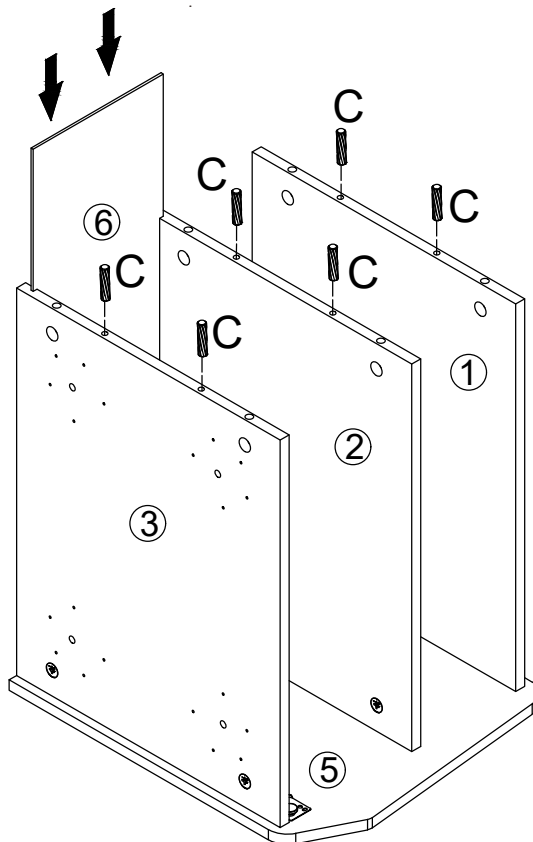

INSTALLATION STEPS

STEP 7

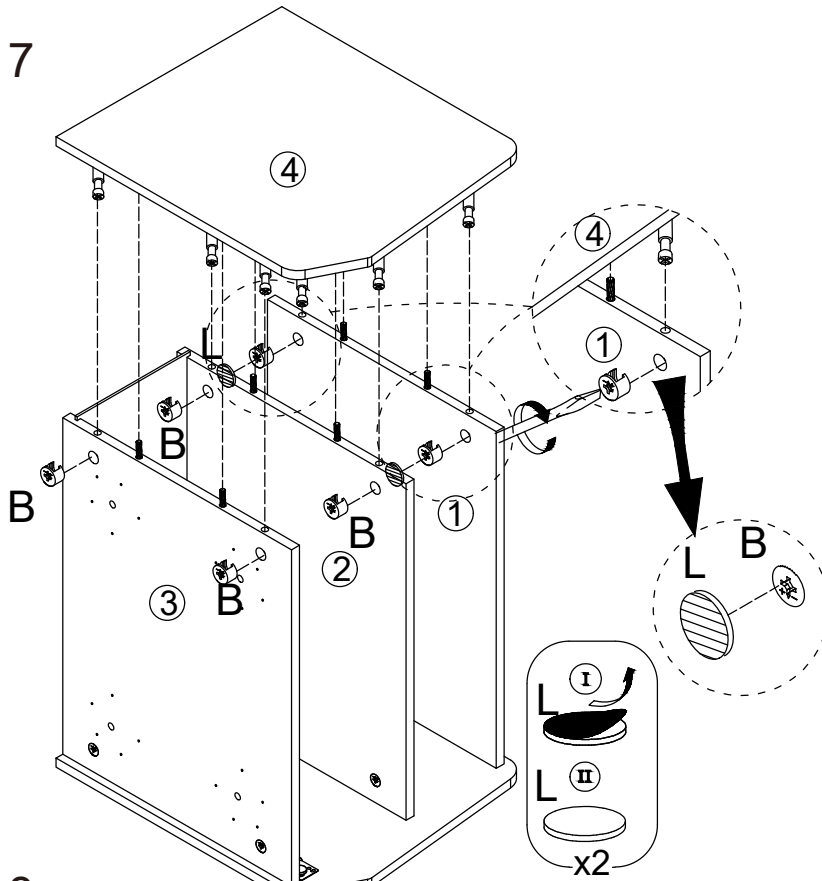



	
B	x6pcs

	
L	x2pcs

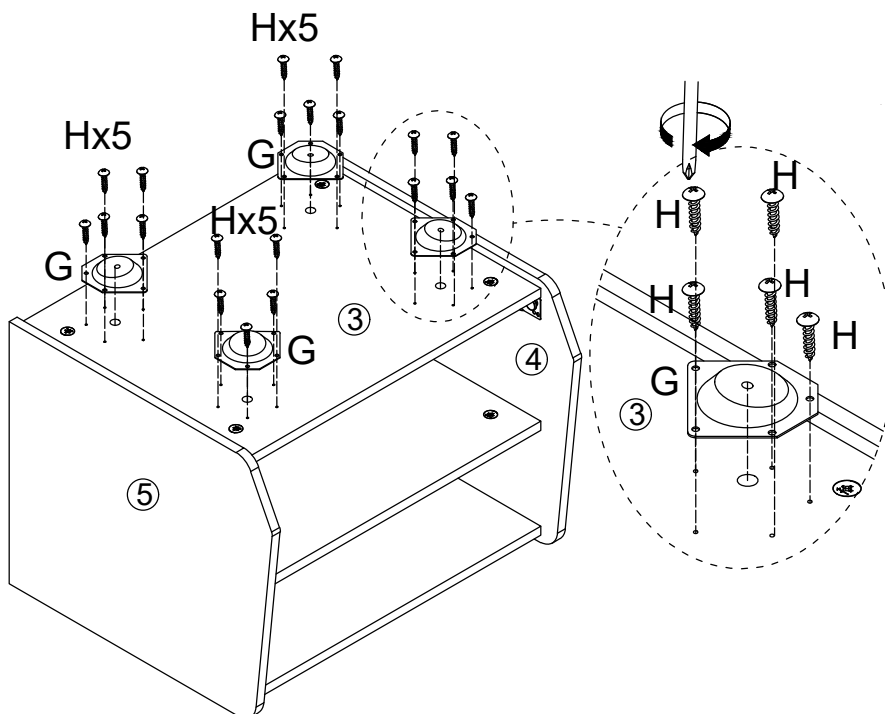
STEP 8



	
G	x4pcs

	
H	x20pcs

INSTALLATION STEPS

STEP 9

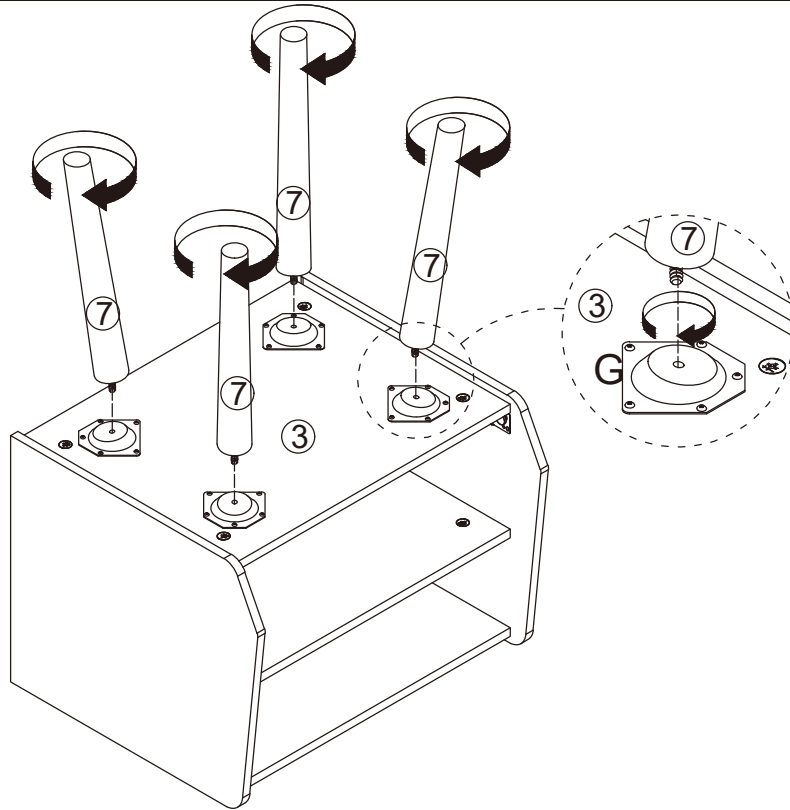

STEP 10

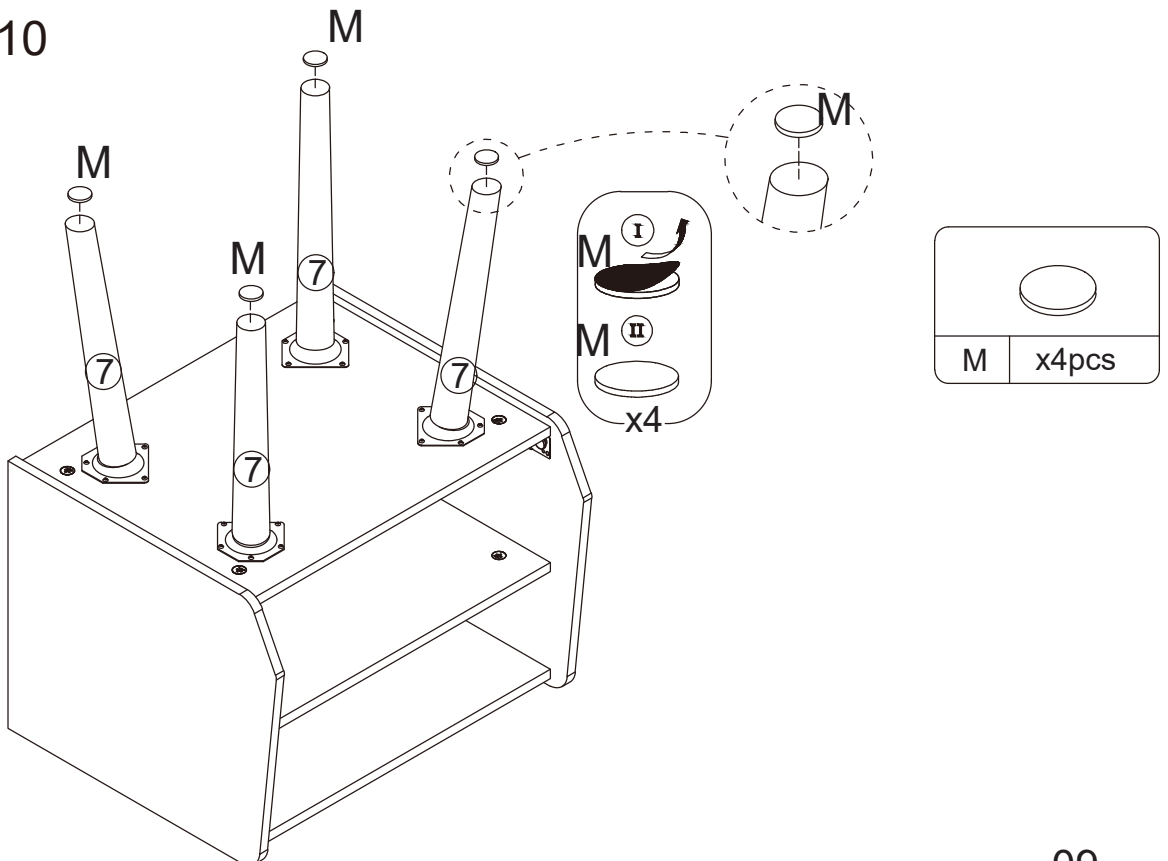

INSTALLATION STEPS

STEP 11

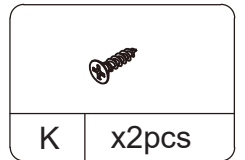
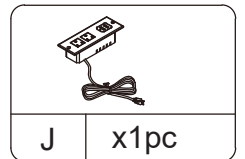
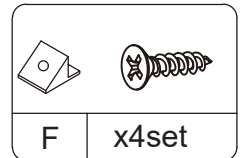
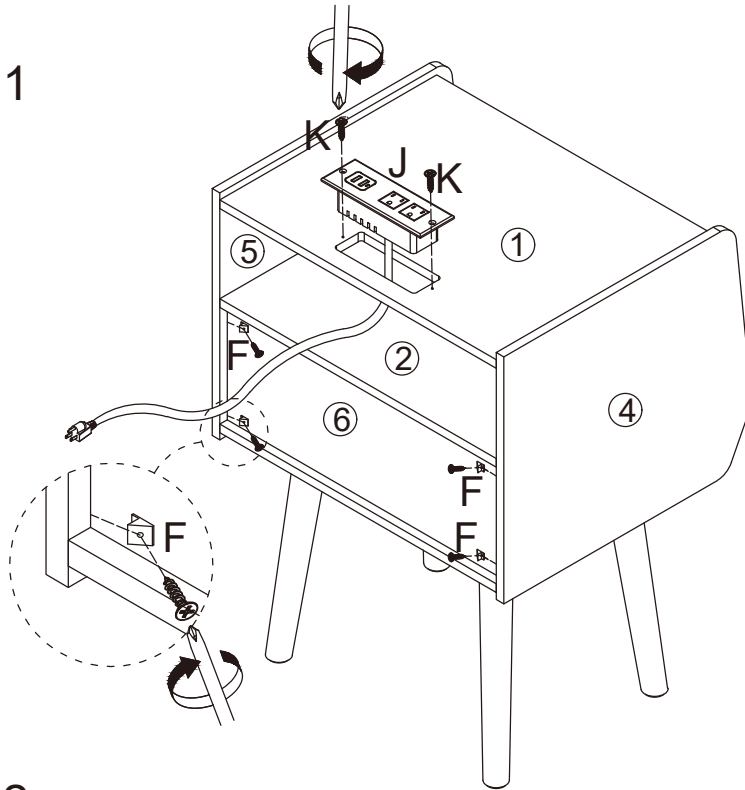

STEP 12

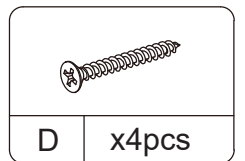
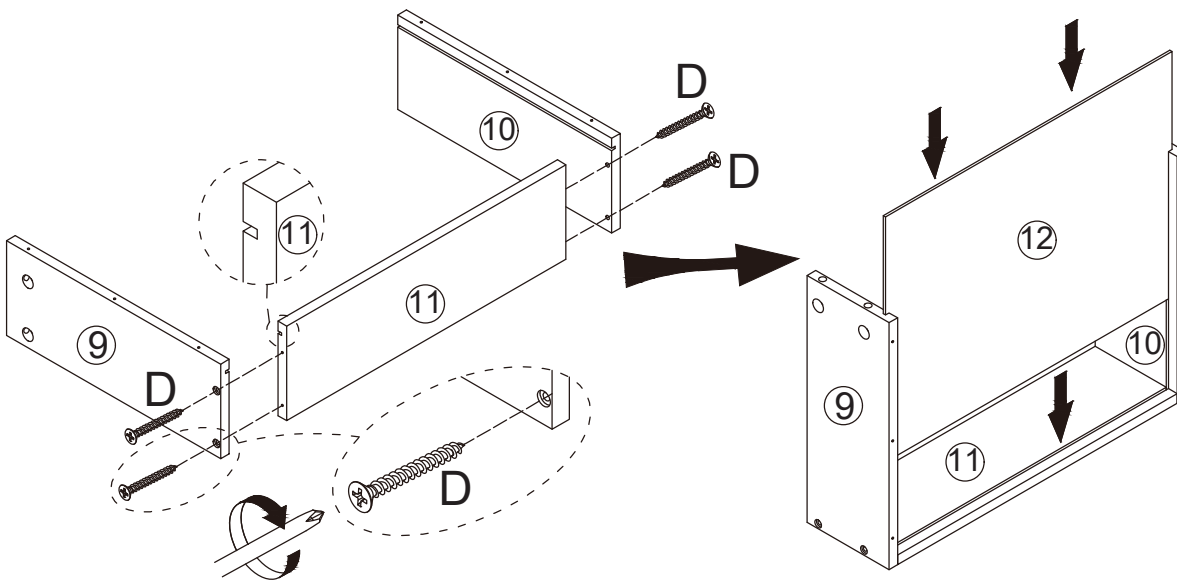

INSTALLATION STEPS

STEP 13

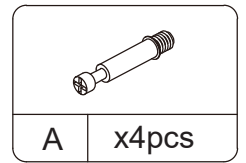
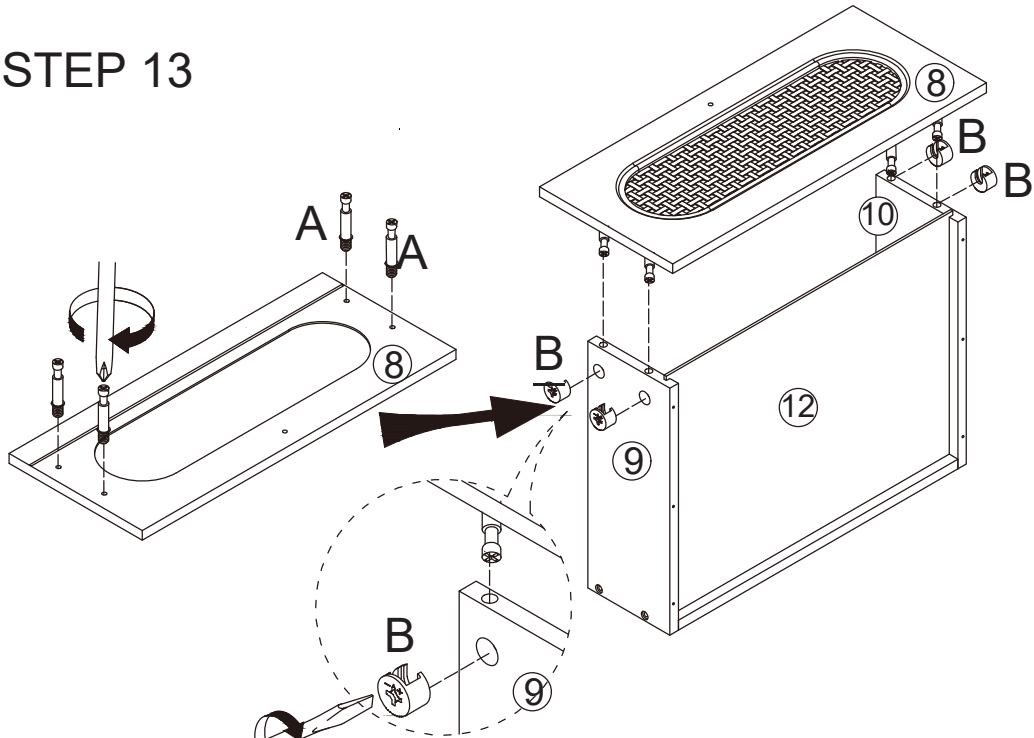

STEP 14

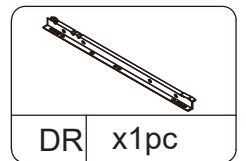
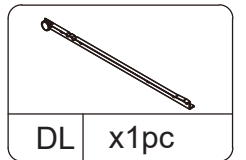
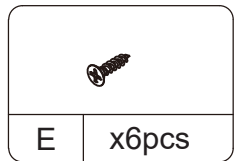
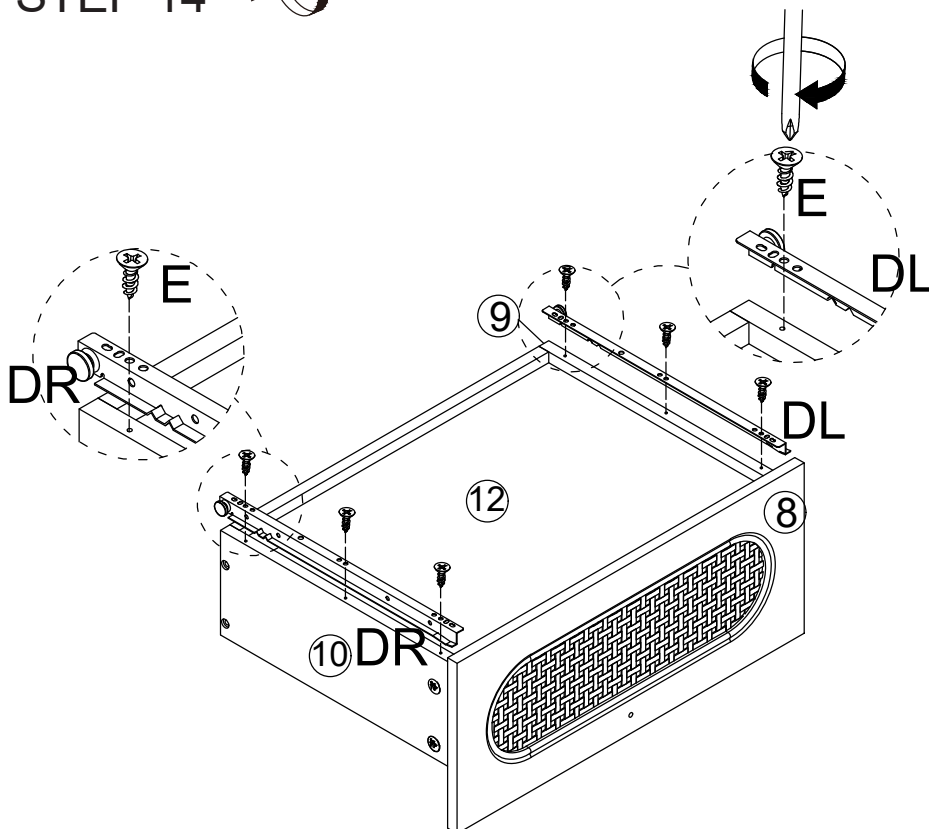

INSTALLATION STEPS

STEP 15

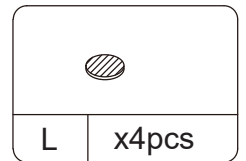
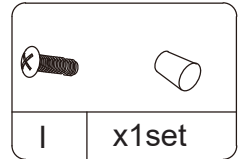
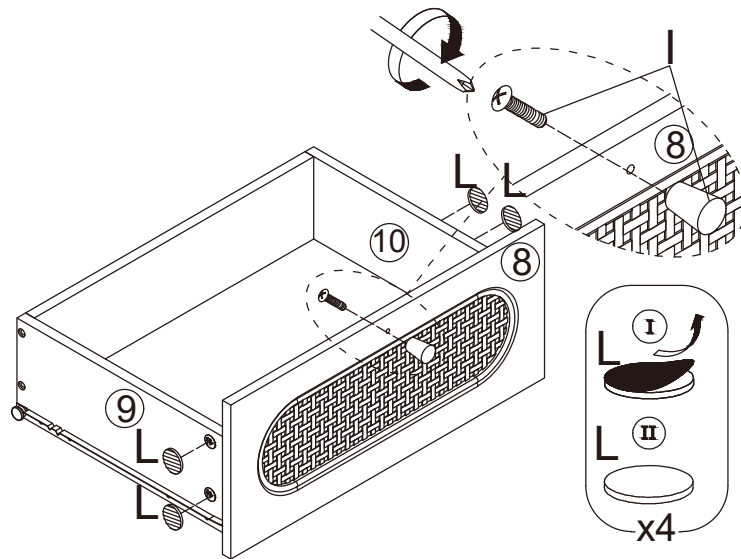

STEP 16

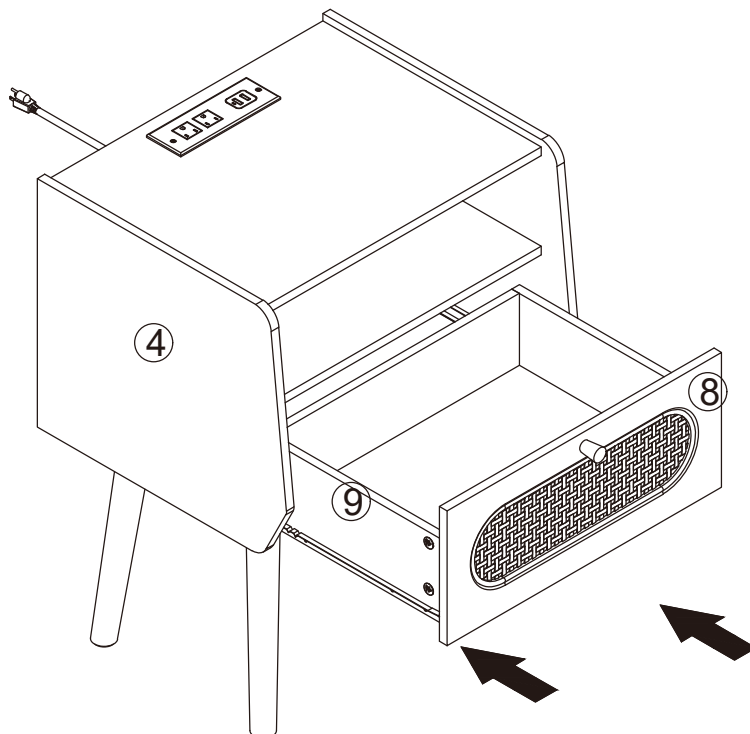

INSTALLATION STEPS

STEP 17

