

MOKR224

24" MOBILE BEVERAGE DISPENSER

MARVEL OUTDOOR COLLECTION



MAIN FEATURES

- 5.7 cu ft. capacity
- Stores half kegs, tall quarter kegs, pony kegs, sixth barrels, Cornelius kegs, bottles or cans
- Lo-Boy coupler makes it easier to store, tap and swap out tall U.S. type D half barrels
- Includes 2 stow-on-board stainless steel shelves to convert unit into refrigerator
- 4 casters included for mobility
- Secure gas tank storage area and drain basin
- Dynamic Cooling Technology delivers temperature stability
- Integrated drain system keeps spillage under control
- Double-insulated tower reduces foam on pour
- Digital controls allow you to select a temperature from 34°F to 60°F
- Beer and wine tap kits with single or twin tap options (sold separately)
- Door ajar and high/low temperature alerts
- Arctic white LED theater-style lighting
- Door lock provides added security
- Reversible door allows for right or left swing
- Designed for outdoor use

WARRANTY

- 1-year parts and labor warranty and 5-year sealed system parts warranty (see complete warranty for details)

FINISH OPTIONS



*Tap kit accessories sold separately

DOOR STYLE	MODEL NUMBER
Solid Stainless Steel (Mobile)	MOKR224-SS31A

TAP KIT ACCESSORIES*	PART #
Wine Single Tap Kit with Nitro Tank & Fittings	S42418647-ACCY
Wine Twin Tap Kit with Nitro Tank & Fittings	S42418648-ACCY
Universal Single Tap Kit with CO2 Tank & Fittings	S42418645-ACCY
Universal Twin Tap Kit with CO2 Tank & Fittings	S42418646-ACCY

*Kit includes tower/tap, regulator, D-style Lo-Boy coupler, gas hose, hose clamps, faucet wrench, tower gasket, tower mounting screws and gas tank.





DIMENSIONAL DRAWINGS

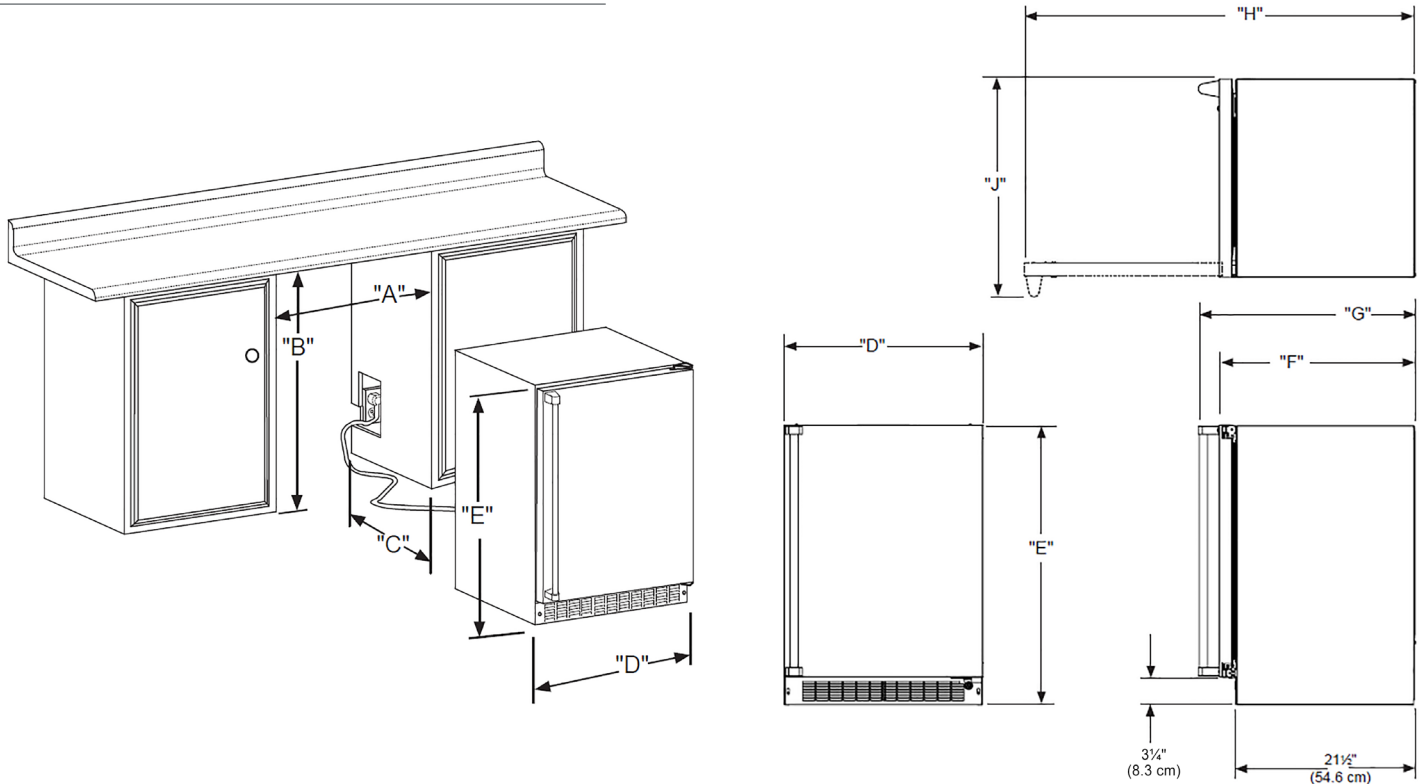

ROUGH IN DIMENSIONS*

"A"	"B"	"C"
24"	34" to 35"	24"
(61 cm)	(86.4 cm to 88.9 cm)	(61 cm)

CABINET DIMENSIONS*

"D"	"E"	"F"	"G"	"H"	"J"
23-7/8"	33-3/4" to 34-3/4"	23-3/4"	26-1/4"	46-3/8"	26-3/8"
(60.7 cm)	(84.5 cm to 87 cm)	(60.3 cm)	(66.2 cm)	(117.8 cm)	(67 cm)

PRODUCT SPECIFICATIONS

Capacity	5.7 CU. FT.
Cord Length	6 FT.
Electrical Requirements	115V / 60 Hz / 15A
ENERGY STAR	Yes
Refrigerant Type	R600a
Sabbath Mode	Yes
Shipping Dimensions	28" W x 31" D x 37" H
Shipping Weight	160 LBS
Temperature Range	34°F to 60°F

For comprehensive installation instructions, including panel overlay details, please visit marvelrefrigeration.com to access the owner's guide. All specifications are subject to change without notice.

