

Assembly Instructions

909232 Seagrass Corner Entertainment - Light OAK
909237 Seagrass Corner Entertainment - Smoked OAK

Product Issues? Please Call Us Before Contacting Your Retailer At 1-800-549-3300

Email customerservice@mshome.co, or visit www.mshome.co

We can help with Assembly Issues, Part Requests, Damages, & All Other Product Related Questions

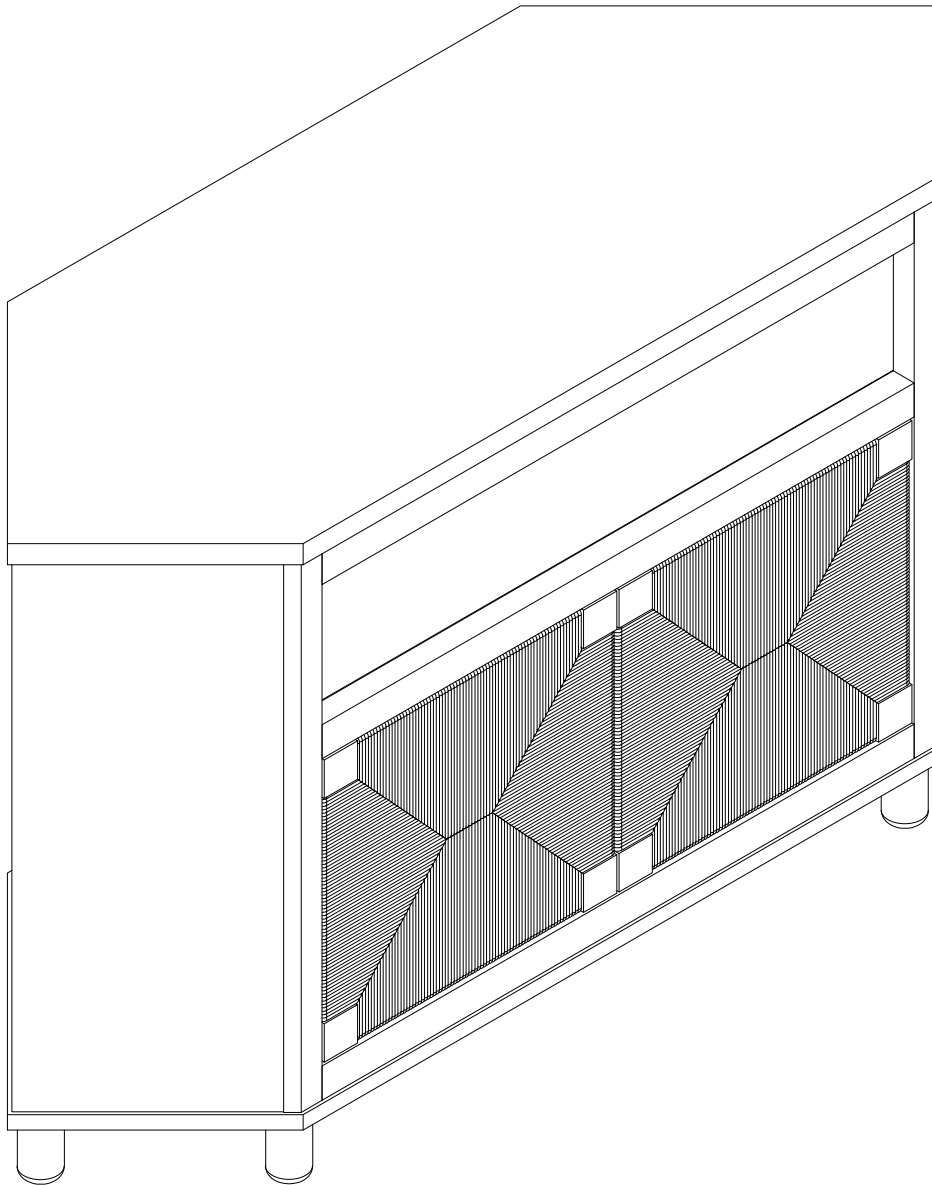

MSH - USA

1-8

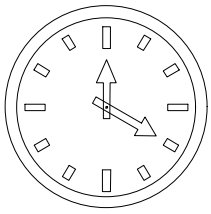

20 min

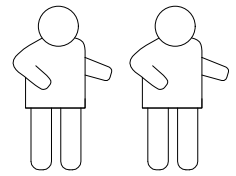

Two People Required
for Assembly

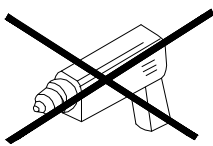
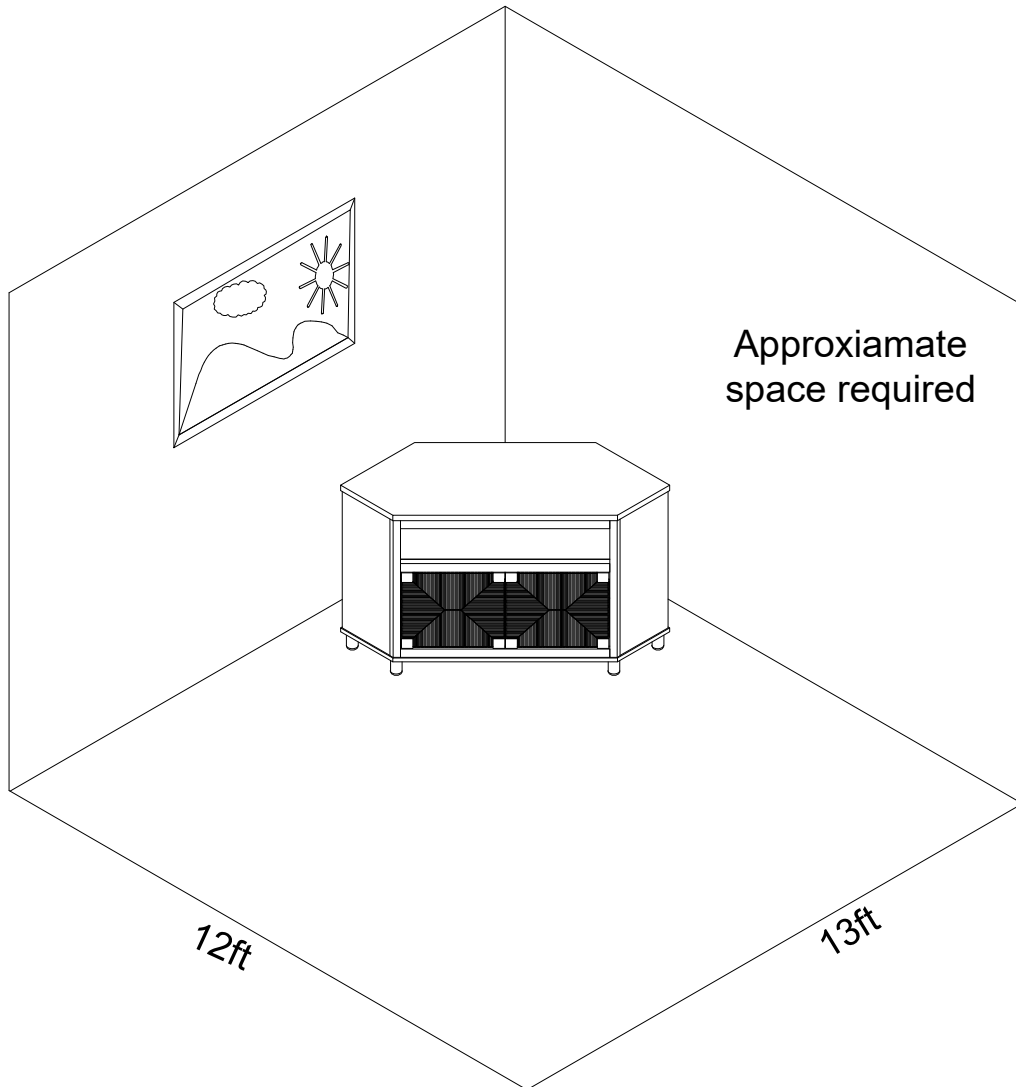

Do Not Use Power Tools

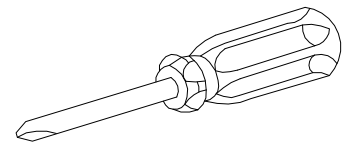

Phillips Head
Not Provide

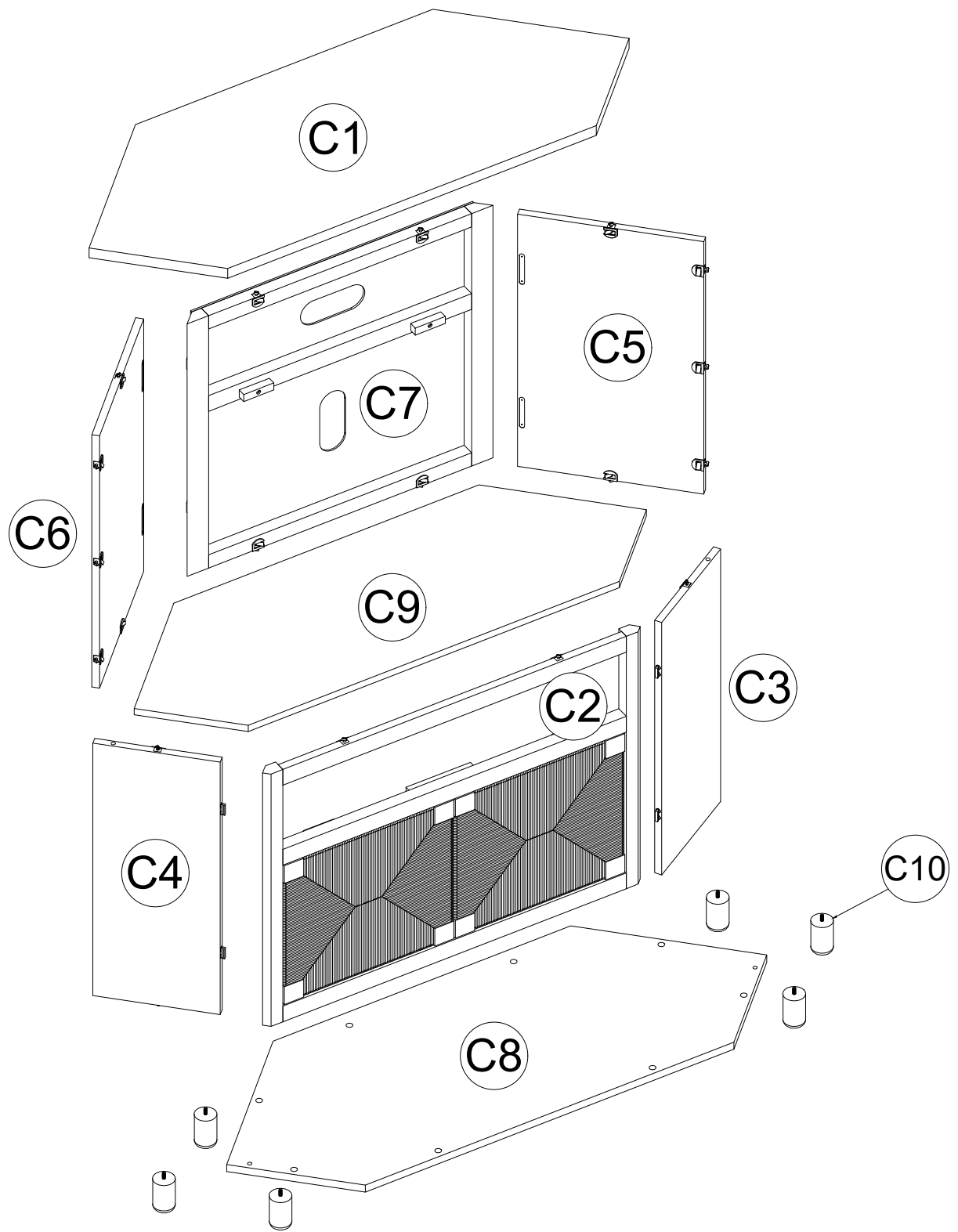

Hardware Pack:

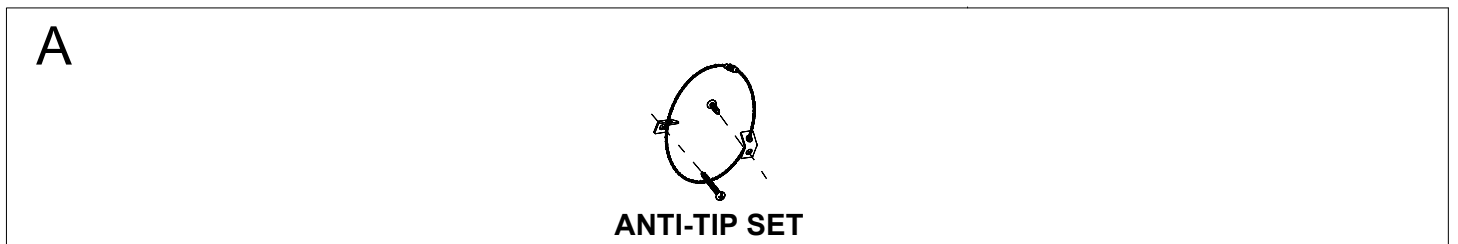

1

Please lay all components on smooth flat surface to prevent scratches
Use the EPE foam to protect the plastic hardware before assembly

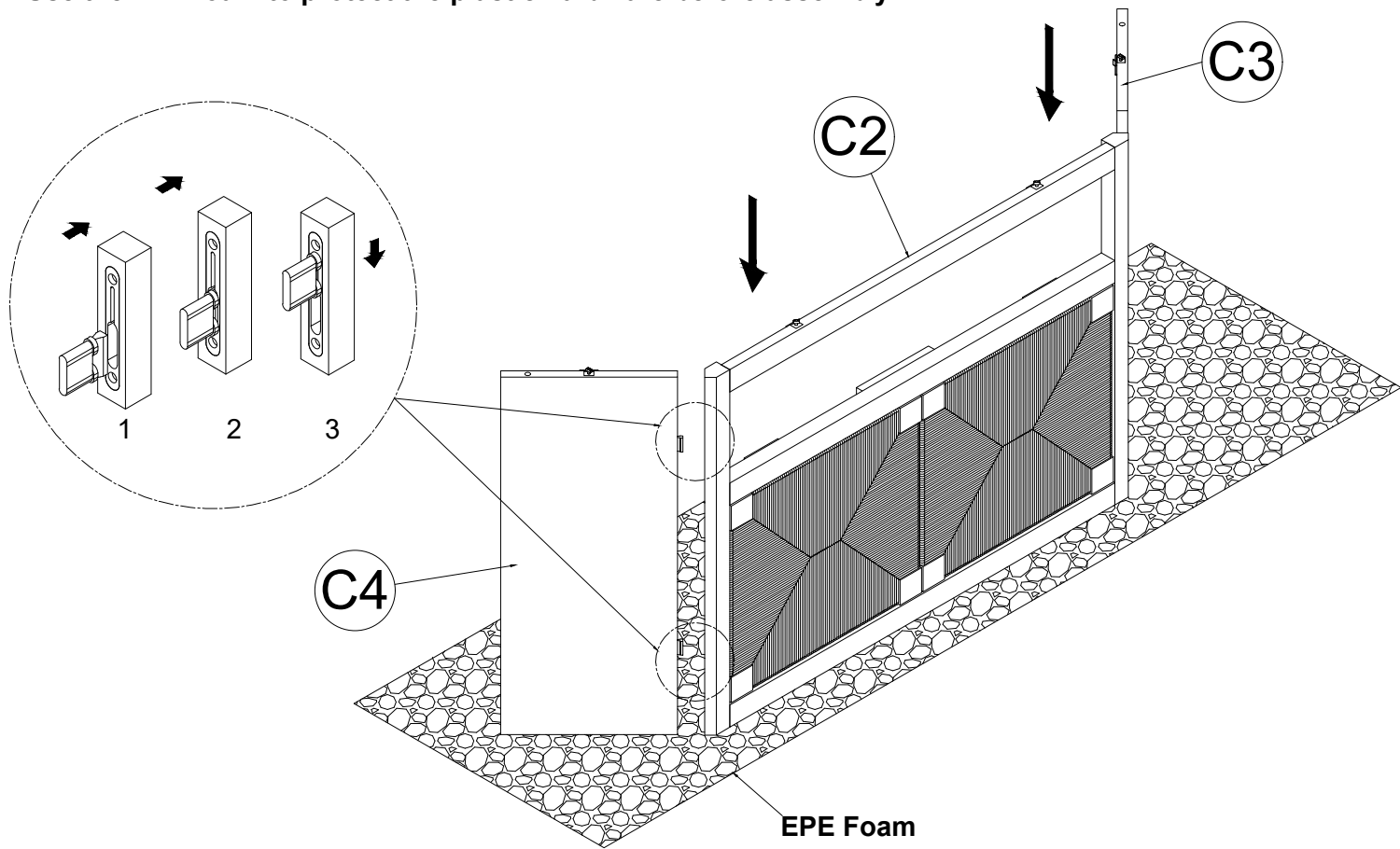

2

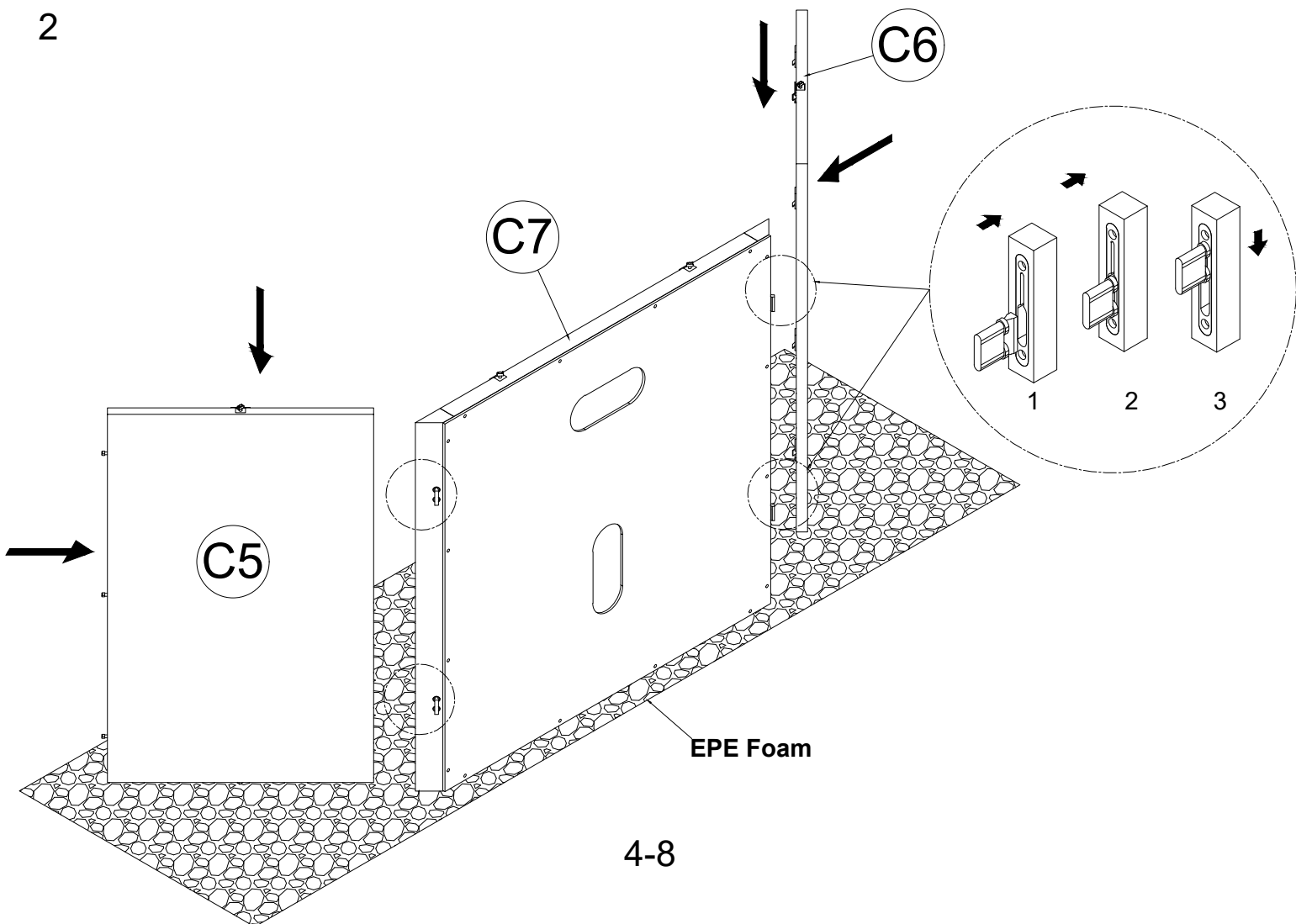

3

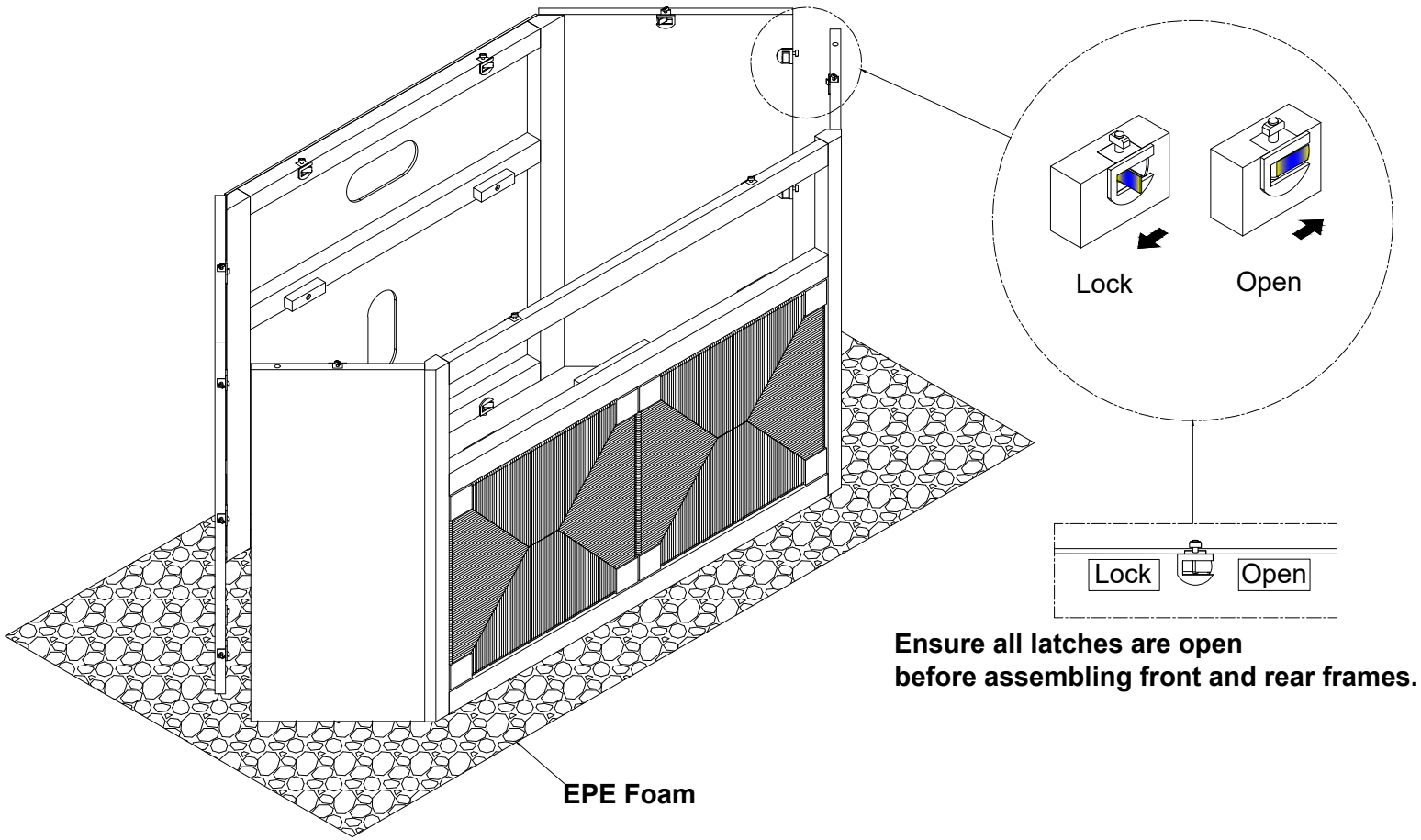

4

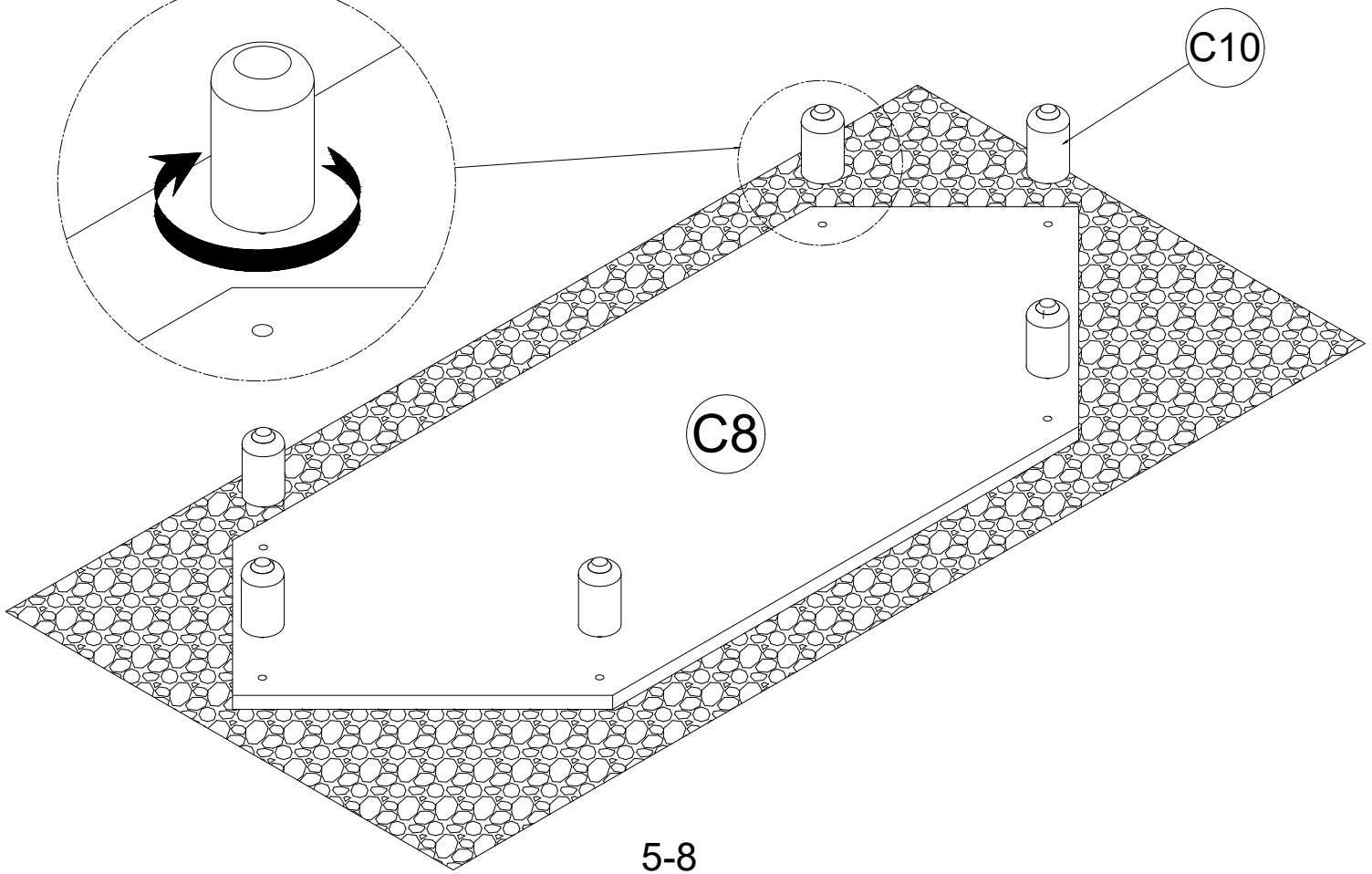

5

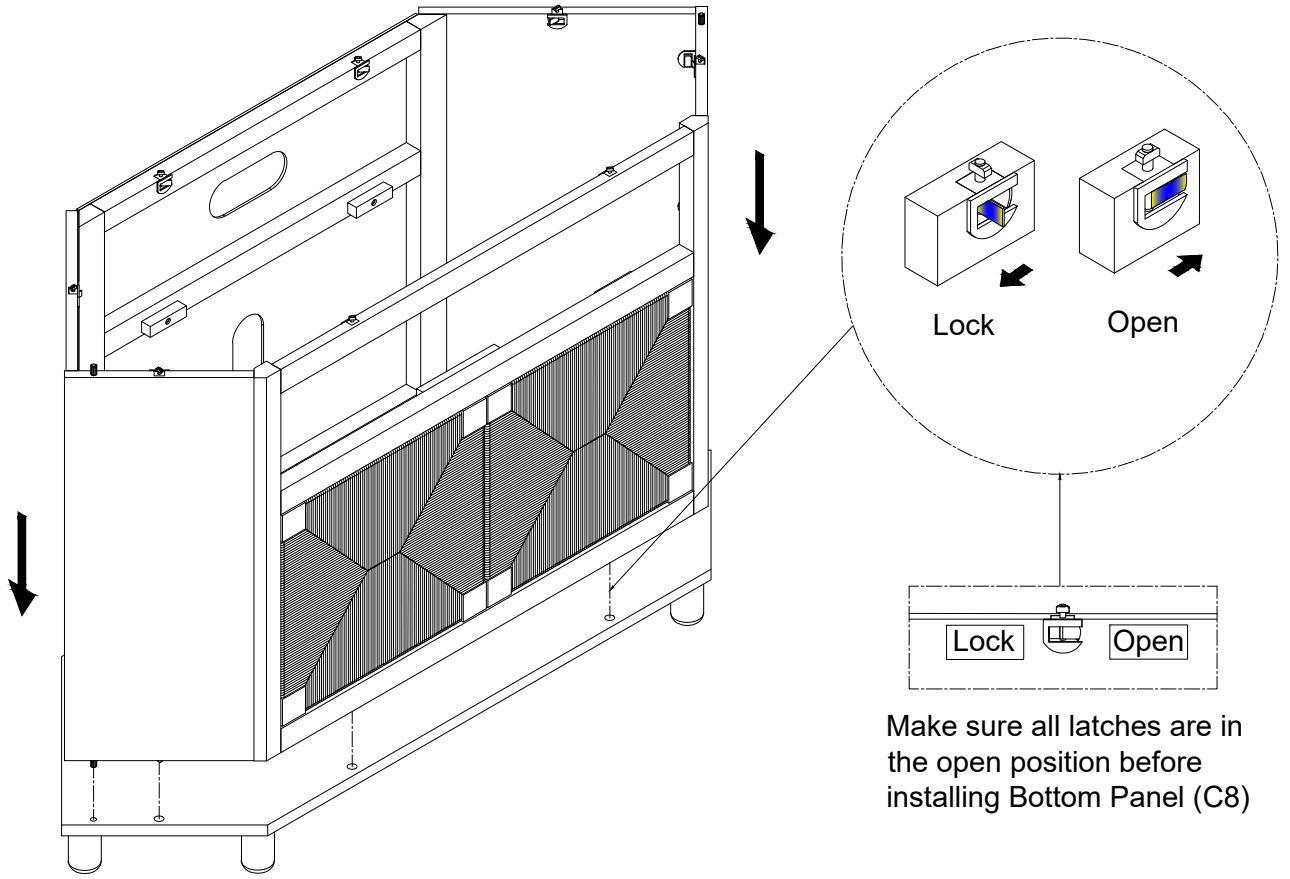

Make sure all latches are in the open position before installing Bottom Panel (C8)

6

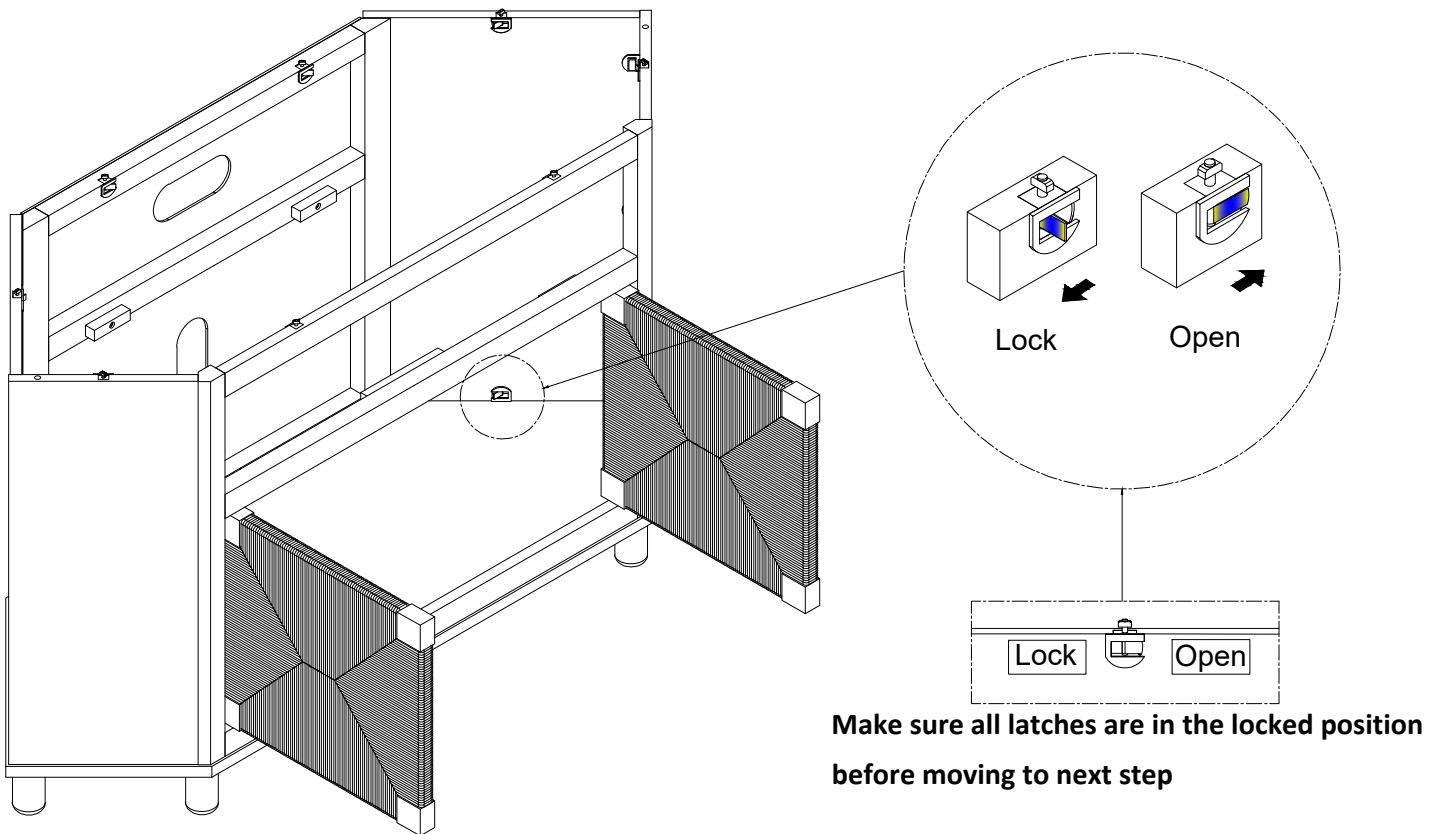

Make sure all latches are in the locked position before moving to next step

6-8

7
Place Middle Shelf (C9) into position onto cleats.
Make sure part is laying flush.

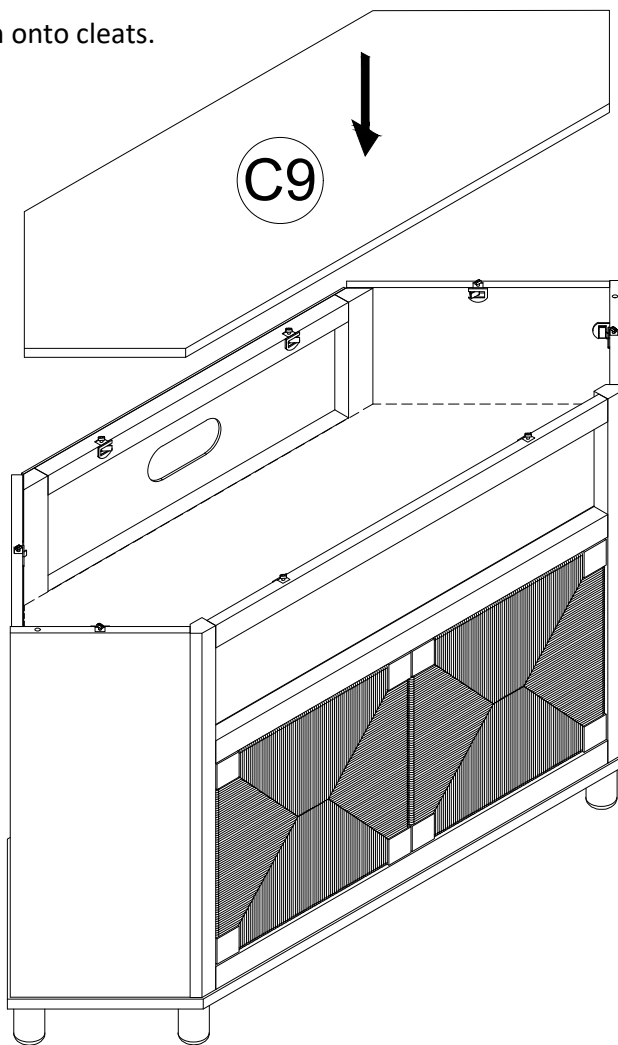

8

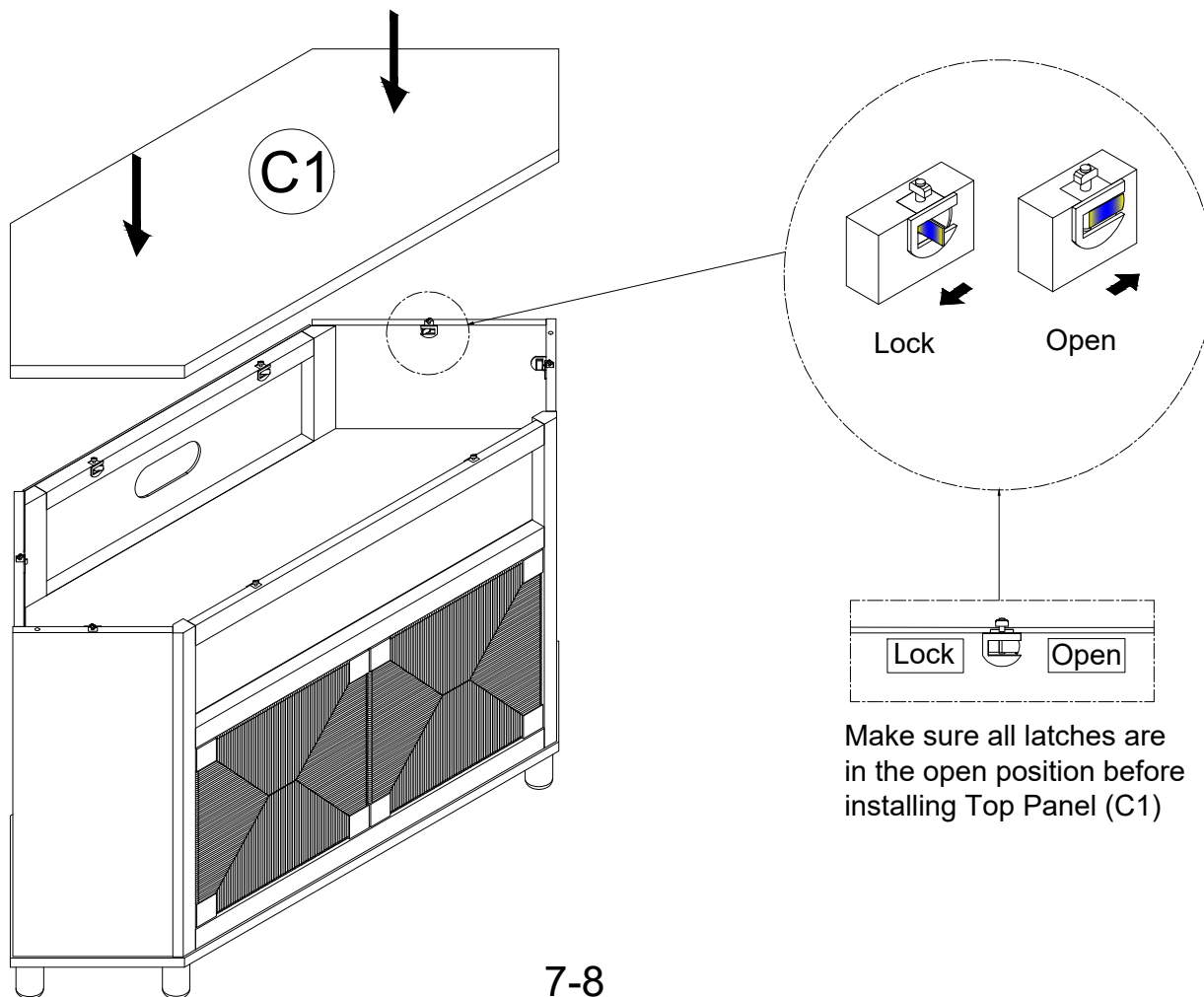

7-8

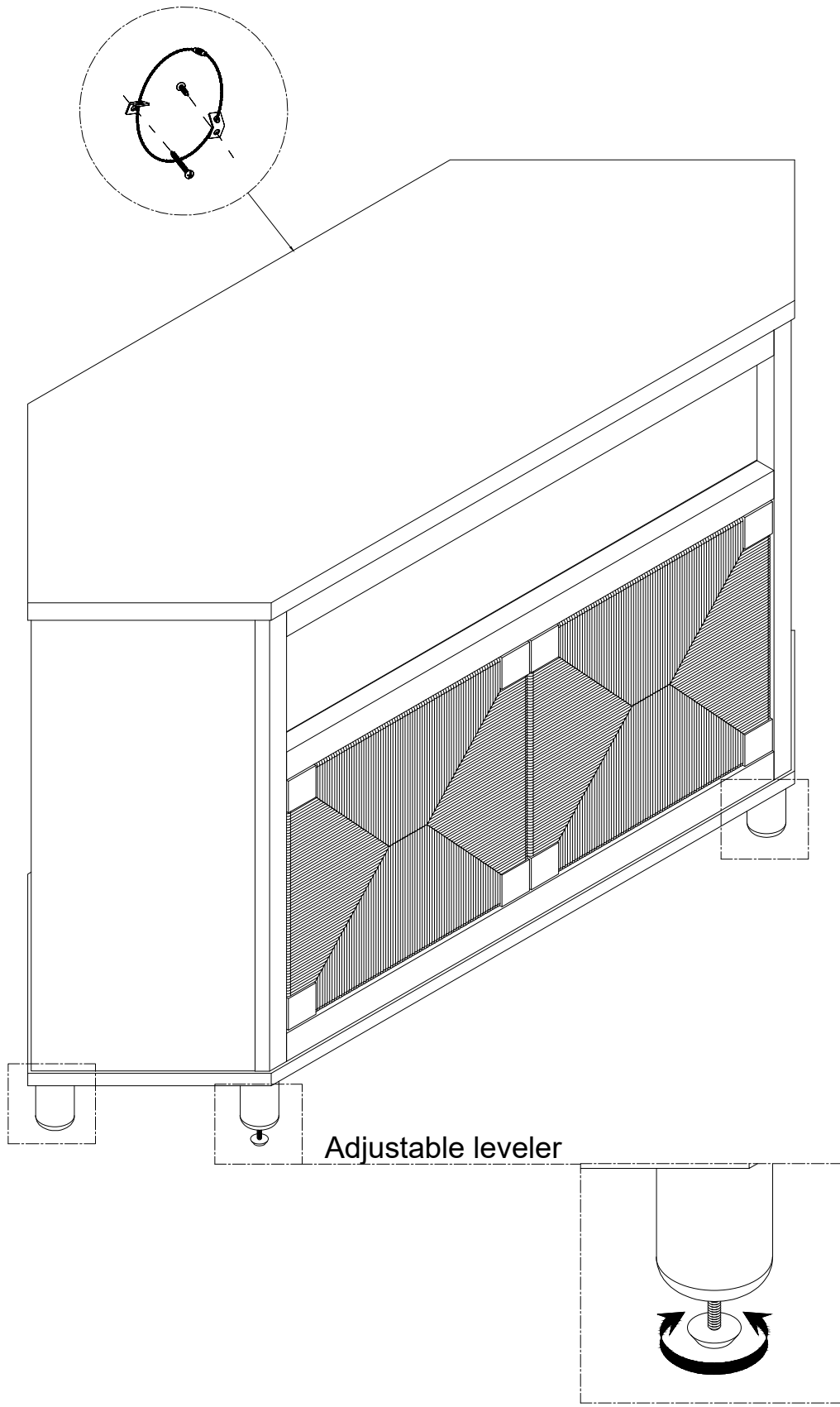

Use the leveling base to attach to the legs for balance.
If the table is rocking, adjust the adjuster until the condition gets better.



Replacement Part Form

Have an issue? Need a replacement part?

Please E-mail us before contacting your retailer, we will be happy to fix your issue.

This process will be hassle free! We will replace your part for free!

Please follow these easy steps below.

You will need to E-mail *Martin Svensson Home* Customer Service: Customerservice@mshome.co
(Please note it is .CO not .com)

Please scan or take a picture of this form filled out.

1. **Customer Name:** _____

2. **SKU# with issue:** _____

3. **Replacement Part # needed** _____

*Please reference the Assembly Instructions to identify needed part #'s

4. **Photos of the Damaged Part** (please include in the e-mail)

5. **Brief description of the part issue:** _____

6. **Proof of Purchase** (please provide a copy of your purchase receipt)

7. **Ship to Address:** _____

8. **Other contact information:**

Email Address _____

Phone # _____

*If possible, could you please provide the UPS or FedEx tracking from original shipment _____

*If possible, could you please provide the P.O. # - information found on back/underneath product _____

*If you have any other question, we are happy to assist with assembly questions or all other parts related questions. Thank you for your purchase!